



STANDARDS AND GUIDELINES FOR COMMUNICATION SITES

Exhibit E



Document Copyrights

© 2005, Motorola, Inc. All rights reserved.

No duplication or distribution of this document or any portion thereof shall take place without the express written permission of Motorola, Inc. No part of this document may be reproduced, distributed, or transmitted in any form or by any means, electronic or mechanical, for any purpose without the express written permission of Motorola.

To order additional copies of this document contact your Motorola sales representative.

Disclaimer

While reasonable efforts have been made to assure the accuracy of the information contained in this document, Motorola, Inc. assumes no liability resulting from any errors or omissions in this document, or from the use of information obtained herein. The information in this document has been carefully checked and is believed to be entirely reliable. However, no responsibility is assumed for inaccuracies. Motorola, Inc. reserves the right to make changes to any products, procedures or practices described herein to improve reliability, function, or design, and reserves the right to revise this document and to make changes from time to time in content hereof with no obligation to notify any persons of revisions or changes. Any standards cited in this document are subject to change without notice.

Motorola, Inc. does not assume any liability arising out of the application or use of any product, circuit, design, recommendation or advice described herein; neither does it convey a license under its patent rights or the rights of others.

Trademark Information

 and Motorola are trademarks of Motorola, Inc.

Any brand or product names appearing in this manual are trademarks or registered trademarks of their respective holders.

Applicability

The standards and guidelines in this revision of this manual shall apply to new communication sites built after the publication date of this revision of the manual. Standards and guidelines in this manual are not required to be implemented at sites built prior to publication of this revision.

**TABLE
OF
CONTENTS**

Chapter 1. Introduction	1-1
1.1 Committee Members	1-1
1.2 Organization of this Manual	1-1
1.3 Safety Information	1-2
1.3.1 Safety Statements Defined	1-2
1.3.2 General Safety Guidelines	1-3
1.4 Standards	1-4
1.4.1 Australia and New Zealand Standards	1-8
1.4.2 Standards Organization Websites	1-10
1.5 Glossary	1-11
Chapter 2. Site Design and Development	2-1
2.1 Compliance with RF Energy Exposure Standards	2-1
2.2 The Motorola Site Design and Integration Team	2-2
2.3 General Outline of Work	2-2
2.4 Planning	2-3
2.4.1 Location of Utility Entrances	2-3
2.4.2 Location of AC Power Neutral-Ground Bond	2-3
2.4.3 Site Development Drawings	2-3
2.4.4 Land Survey and Site Development Staking Considerations	2-4
2.4.5 Temporary Facilities	2-5
2.4.6 Geotechnical Considerations	2-6
2.5 Constructability Review	2-7
2.6 Site Walks	2-7
2.7 Permitting, Zoning, Code and Regulatory Considerations	2-9
2.7.1 Americans With Disabilities Act Considerations	2-9
2.7.2 Federal Clean Water Act Considerations	2-10
2.8 Fire Suppression	2-10
2.9 Electrical Service	2-10
2.10 Foundation Design and Installation	2-11
2.10.1 Foundation and Geotechnical Services	2-11
2.10.2 Concrete Foundation Design and Installation Considerations	2-12
2.10.3 Concrete and Soils Installation Monitoring	2-14
2.11 Site and Facility Acceptance Testing	2-16
2.12 Tower Design and Construction	2-16
2.12.1 Tower Design Drawings	2-18
2.12.2 Design Considerations to Help Reduce Effects of Lightning	2-19
2.12.3 Tower Safety	2-22
2.12.4 Regulations Affecting Towers	2-22
2.12.5 Securing the Tower	2-23
2.12.6 Antenna and Dish Antenna Loading	2-23
2.12.7 Tower Construction	2-25
2.12.8 Tower Transmission Cables	2-25
2.13 Site Drawings of Record	2-27

Chapter 3. Communication Site Building Design and Installation 3-1

3.1 Site Categories	3-1
3.2 Definitions of Communications Equipment Sites	3-2
3.3 Building/shelter Design and Location Considerations	3-5
3.3.1 Location Considerations	3-7
3.3.2 Equipment Shelter Off-Loading	3-7
3.3.3 Seismic Considerations	3-8
3.4 Foundation Considerations	3-8
3.5 Floor Loading	3-9
3.6 Ceilings and Floors	3-10
3.6.1 Ceilings	3-10
3.6.2 Floors	3-11
3.7 Weatherproofing/Sealing	3-11
3.7.1 Transmission Line Entry Ports	3-11
3.7.2 Sealing of Buildings and Shelters	3-13
3.8 Heating, Ventilation, and Air Conditioning	3-13
3.8.1 HVAC Design Considerations	3-14
3.9 Special Considerations for Telephone Central Offices and Switch Rooms	3-17
3.9.1 Lightning Damage Prevention	3-17
3.9.2 Power Source Protection	3-17
3.9.3 Central Office Layout	3-17
3.10 Cable Trays	3-18
3.10.1 Cable Tray Selection	3-18
3.10.2 Cable Management under Raised Floors	3-19
3.10.3 Wire-mesh Cable Trays	3-19
3.10.4 Cable Tray Layout And Design	3-20
3.10.5 Cable Tray Installation	3-21
3.10.6 Cable Tray Safety Considerations	3-22
3.11 Lighting	3-22
3.11.1 General Interior Lighting Specifications	3-22
3.11.2 Interior Lighting Quality	3-22
3.11.3 Emergency Interior Lighting	3-23
3.11.4 Exterior Lighting	3-23
3.12 Fire Protection/Safety	3-23
3.12.1 Reference Publications	3-24
3.12.2 Training and Proper Usage	3-24
3.12.3 Minimum Required Fire Extinguishers	3-24
3.12.4 Required Standards for Portable Fire Extinguishers	3-25
3.12.5 Fire Extinguisher Installation	3-25
3.12.6 Fixed Fire Detection, Alarm, and Suppression Systems	3-26
3.12.7 Warning Signs	3-27
3.12.8 Power Sources	3-28
3.12.9 Fixed Systems Comparison	3-28
3.13 Safety Equipment	3-29
3.13.1 First Aid Kit	3-30
3.13.2 Typical Battery Safety Kit	3-30
3.14 On Site Communications	3-30
3.15 Signage	3-31
3.15.1 Minimum Required Signage	3-31
3.15.2 Additional Signage	3-32

Chapter 4. External Grounding (Earthing)	4-1
4.1 Introduction	4-1
4.2 Lightning Activity and Exposure	4-3
4.3 Common Grounding (Earthing)	4-5
4.4 Grounding (Earthing) Electrode System Component and Installation Requirements	4-7
4.4.1 Grounding (Earthing) Electrodes	4-9
4.4.2 Grounding (Earthing) Conductors	4-28
4.4.3 External Ground Bus Bar	4-30
4.5 Dissimilar Metals and Corrosion Control	4-34
4.5.1 Corrosion Related to Soil Type	4-34
4.5.2 Galvanic Corrosion	4-36
4.5.3 Miscellaneous General Information	4-38
4.5.4 Methods To Help Reduce Corrosion	4-38
4.6 Bonding to the External Grounding (Earthing) Electrode System	4-40
4.6.1 Requirements	4-40
4.6.2 Bonding Methods	4-41
4.7 Minimum Site Grounding (Earthing) Requirements	4-44
4.7.1 Type “A” Site - Light Duty	4-44
4.7.2 Type “B” Site - Standard Duty	4-45
4.7.3 Special Grounding (Earthing) Situations	4-45
4.7.4 Grounding (Earthing) Electrode System Resistance Requirements	4-46
4.7.5 Type “A” Site Grounding (Earthing)	4-48
4.7.6 Tower Grounding (Earthing)	4-50
4.7.7 Dedicated Communications Building Grounding (Earthing)	4-59
4.7.8 Outdoor Cabinet Grounding (Earthing)	4-61
4.7.9 RF Transmission Line and Preamplifier Grounding (Earthing)	4-62
4.7.10 Metallic Objects Requiring Bonding	4-67
4.7.11 Metallic Building Siding Grounding (Earthing)	4-74
4.8 Grounding (Earthing) Roof-Mounted Antenna Masts and Metal Support Structures	4-74
4.8.1 Side Mounted Antenna Grounding (Earthing)	4-77
4.9 Grounding (Earthing) Rooftop Mounted Tower Structures	4-79
4.10 Special Grounding (Earthing) Applications	4-81
4.10.1 External Grounding (Earthing) For Dispatch Centers Co-located With Communications Towers	4-81
4.10.2 Two or More Electrically Interconnected Separate Buildings Located in the Same General Area	4-83
4.10.3 Access Point and Wireless Router Grounding (Earthing)	4-84
4.10.4 Metal Shipping Containers Used As Communications Buildings	4-87
4.10.5 Grounding (Earthing) Electrode Systems Covered by Concrete or Asphalt	4-88
4.11 Special Grounding (Earthing) Situations	4-88
4.11.1 Rooftop and Integrated Communications Sites	4-89
4.11.2 Sites With Limited Space for the Grounding (Earthing) Electrode System	4-90
4.11.3 Towers With Limited Space For A Ground Ring	4-92
4.11.4 Stone Mountain Tops	4-92
4.11.5 Sand, Coral, or Limestone Environments	4-96
4.11.6 Shallow Topsoil Environments	4-97
4.11.7 Grounding (Earthing) in Arctic Regions	4-99

Chapter 5. Internal Grounding (Earthing)	5-1
5.1 Introduction	5-1
5.2 Common Grounding (Earthing)	5-3
5.3 Grounding (Earthing) System Components and Installation Requirements	5-4
5.3.1 Master Ground (Earth) Bus Bar	5-9
5.3.2 Sub System Ground (Earth) Bus Bar	5-15
5.3.3 Rack Ground (Earth) Bus Bar	5-20
5.3.4 Grounding (Earthing) Conductors	5-20
5.3.5 Ground (Earth) Bus Conductors	5-24
5.3.6 Communication Bonding Backbone Conductor and Grounding (Earthing) Equalizer Conductors	5-25
5.3.7 Internal Perimeter Ground (Earth) Bus Conductors	5-28
5.3.8 Equipment Grounding (Earthing) Conductors	5-29
5.3.9 Bonding Jumpers	5-30
5.4 Connection Methods for Internal Grounding (Earthing) System	5-31
5.4.1 General Bonding Requirements	5-31
5.4.2 Bonding to Equipment and Ancillary Support Apparatus	5-34
5.4.3 Bonding to the MGB, SSGB And RGB	5-36
5.4.4 Bonding to Ground (Earth) Bus Conductors	5-38
5.4.5 Bonding to Communication Bonding Backbone Conductors and Grounding (Earthing) Equalizer Conductors	5-39
5.5 Bonding Equipment to Internal Grounding (Earthing) System	5-40
5.5.1 Equipment and Ancillary Support Apparatus Bonding	5-41
5.6 Grounding (Earthing) for Stand-alone Equipment Shelters	5-54
5.6.1 Installation Requirements for Stand-Alone Shelters	5-55
5.7 Grounding (Earthing) for Small, Large, and Multi-Story Buildings	5-58
5.7.1 Establishing a Communication Grounding (Earthing) System	5-58
5.7.2 Specifications for Conductors	5-59
5.7.3 Bonding Connections for the MGB	5-60
5.7.4 Bonding Connections for the SSGB	5-60
5.7.5 Items to be Bonded to the Internal Ground (Earth) System	5-61
5.8 Grounding (Earthing) for Dispatch Centers and Network Operator Positions	5-62
5.8.1 Grounding (Earthing) and Protection of Incoming Power and Telecommunication Cables	5-63
5.8.2 Grounding (Earthing) of Equipment Rooms Located Within the Dispatch Center	5-63
5.8.3 Grounding (Earthing) and Protection of Network Operator Positions and Work Areas	5-64
5.9 Grounding (Earthing) for Integrated Communication Sites	5-68

Chapter 6. Power Sources	6-1
6.1 Lockout/Tagout	6-1
6.2 AC Power	6-1
6.2.1 Electrical Service	6-2
6.2.2 Location of Neutral-Ground Bond	6-4
6.2.3 Separately Derived Systems Using Transformers	6-5
6.2.4 Interior Electric	6-6
6.2.5 Power Panels	6-7
6.2.6 Circuit Protection	6-8
6.2.7 Conductors	6-9
6.2.8 Conduit	6-9
6.2.9 Hardwiring of Equipment and Dedicated Receptacles	6-10
6.2.10 Receptacles	6-10
6.2.11 Receptacle Strips	6-11
6.3 Power Quality	6-11
6.3.1 Fundamentals of Power Quality	6-12
6.3.2 Common Causes of Power Quality Problems	6-12
6.3.3 Common Effects of Power Quality Problems	6-15
6.3.4 Common Power Quality Problem Remedies	6-16
6.3.5 Power Quality Testing Thresholds	6-17
6.3.6 Steps to Developing a Power Quality Plan	6-17
6.3.7 General Recommendations to Help Promote Good Power Quality	6-18
6.3.8 Power Quality Testing Locations	6-18
6.3.9 Power Quality Testing Duration	6-19
6.4 Rectifier/DC Power Systems	6-19
6.4.1 Rectifier System Requirements	6-19
6.4.2 DC Distribution	6-21
6.4.3 Low Voltage Disconnect	6-21
6.4.4 Overcurrent Protection	6-21
6.4.5 Power Cabling Capacity	6-21
6.4.6 Floor And Ceiling Runs, Plenum Grade And Risers Cabling	6-22
6.4.7 DC Power Budget	6-23
6.5 Uninterruptible Power Supplies	6-24
6.5.1 Determining UPS Output Requirements	6-24
6.6 Alternate Power Sources	6-25
6.6.1 System Planning	6-25
6.6.2 Requirements	6-26
6.6.3 Installation	6-27
6.6.4 Maintenance	6-27
6.7 Battery Systems	6-27
6.7.1 Battery Safety	6-28
6.7.2 Battery Containment Area	6-30
6.7.3 Battery Backup Duration	6-31
6.7.4 Battery Sizing	6-32
6.7.5 Battery Rating	6-32
6.7.6 Multiple Battery Strings	6-32
6.7.7 Battery Charging	6-33
6.7.8 Battery Temperature Requirements	6-33
6.7.9 Battery Installation	6-34
6.7.10 Battery Maintenance Disconnect	6-35
6.8 Standby Generator Systems	6-35

6.9 Generator Output and Derating Considerations	6-36
6.9.1 Generator Placement	6-37
6.9.2 Fuel Supply	6-38
6.9.3 Transfer Switch	6-40
6.9.4 Electrical Wiring Considerations	6-40
6.9.5 Installation Plan	6-40
6.9.6 Alarms, Meters and Gauges	6-41
6.9.7 Generator Installation Grounding	6-42
6.9.8 Generator Installation	6-42
6.9.9 Generator Startup	6-43
6.9.10 Generator Safety	6-43

Chapter 7. Surge Protective Devices 7-1

7.1 Introduction	7-1
7.2 Technologies Available	7-4
7.3 Suppression Mode Definitions	7-4
7.4 AC Power SPD Requirements	7-5
7.4.1 AC SPD Requirements Based on Facility Description	7-5
7.4.2 SPD Types	7-27
7.4.3 Installation Requirements	7-33
7.5 Telephone/Control/Data Network Circuit SPDs	7-34
7.5.1 Primary Protection	7-35
7.5.2 Secondary Protection	7-35
7.5.3 Fiber Optic Cables	7-36
7.6 RF Components Protection	7-36
7.6.1 RF Surge Suppression Technology Overview	7-37
7.6.2 Surge Protection Considerations for Dispatch Centers and Operator Positions	7-43
7.6.3 Cable Television and Security Systems	7-44
7.6.4 Broadband - Wireless Access Point Networks	7-44
7.7 GPS Receiver Protection	7-44
7.8 Tower Lighting Protection	7-45
7.9 Battery Powered Protection	7-47
7.10 AC Power Line SPD Test Certification Requirements	7-47
7.10.1 Test Methods	7-48
7.10.2 Component Level Surge Test	7-48
7.10.3 Impulse Surge Durability Test Requirements	7-49
7.10.4 Maximum Discharge Current Test	7-50

Chapter 8. Minimizing Site Interference	8-1
8.1 Interference Protection Recommendations	8-1
8.1.1 Minimum Transmitter Protection Requirements	8-2
8.1.2 Minimum Receiver Protection Requirement	8-3
8.2 General Site Environmental Requirements	8-3
8.3 Other Band Architecture—Overview	8-4
8.3.1 Spectrum Usage History	8-4
8.3.2 Forms of Interference	8-4
8.3.3 OBA Interference Mitigation	8-5
8.3.4 Antenna Network Components	8-7
8.3.5 Optimization and Testing	8-8
8.3.6 Maintenance	8-8
8.4 Mitigating External Intermodulation and Transmitter Noise / Receiver Desense Interference	8-8
8.4.1 Intermodulation	8-9
8.4.2 Transmitter Noise/Receiver Desense	8-9
8.4.3 Simplex Multi-Frequency Stations	8-10
 Chapter 9. Equipment Installation	 9-1
9.1 Introduction	9-1
9.2 Facility Readiness	9-1
9.3 General Considerations for Layout, Work Areas, and Spacing	9-2
9.3.1 Spacing Requirements	9-2
9.4 Seismic Considerations	9-3
9.4.1 General Recommendations	9-3
9.5 Equipment Mounting Plumb and Squareness	9-5
9.6 Equipment Anchoring	9-5
9.6.1 Mounting on Concrete Floors	9-6
9.6.2 Mounting On Wood or Fiberglass Floors	9-8
9.6.3 Anchoring Equipment to Raised Floors	9-9
9.6.4 Anchoring Overhead and Wall-mounted Equipment	9-9
9.7 Equipment Installation Within Racks or Cabinets	9-10
9.8 Ancillary Equipment Mounting	9-10
9.9 Equipment Cabling	9-11
9.9.1 Cabling Requirements for Equipment in Racks and Cabinets	9-11
9.9.2 Communication Cabling Requirements for Plenums and Other Air-Handling Spaces	9-12
9.9.3 Cabling Requirements for Cable Trays or Ladders	9-14
9.9.4 AC Power Cabling	9-16
9.9.5 DC Power Cabling	9-17
9.9.6 Computer Network Cabling	9-18
9.9.7 Optical Fiber Cabling	9-26
9.9.8 RF Cabling	9-28
9.9.9 Cabling in Telephone Wiring Environments	9-28
9.9.10 Distribution Frame Configurations	9-29
9.9.11 Distribution Frame Cross-Connect Wiring	9-30
9.9.12 Cable Labeling	9-30
9.10 Electrostatic Discharge Considerations	9-31

Appendix A. Electromagnetic Energy Information	A-1
A.1 Introduction	A-1
A.2 Environmental Evaluation	A-2
A.2.1 Exposure Standards and Limits	A-3
A.2.2 Compliance Analysis	A-5
A.2.3 Exposure Evaluation	A-6
A.2.4 EME Zoning	A-10
A.2.5 Characterization Zoning	A-12
A.3 Engineering Considerations	A-14
A.3.1 Antenna Elevation	A-14
A.3.2 Extending Antennas Away From Towers	A-15
A.3.3 Collocated Broadcast Transmitters	A-16
A.3.4 Location of Directional Antennas	A-16
A.3.5 Antenna Selection	A-17
A.3.6 Mounting Density of Antennas	A-17
A.3.7 Uptime	A-18
A.3.8 Antenna Site Documentation	A-19
A.4 Work Practices	A-20
A.4.1 Training and Qualification Verification	A-20
A.4.2 Physical Access Control	A-20
A.4.3 Policing	A-21
A.4.4 Chain of Authority and Reporting Requirements	A-21
A.4.5 Understanding Site Responsibilities Under Shared Conditions	A-21
A.4.6 General Procedures	A-21
A.4.7 Site Specific Procedures	A-23
A.4.8 Operating Procedures	A-24
A.5 Signage	A-24
A.6 Personal Protective Equipment (PPE)	A-26
A.6.1 Protective Clothing	A-26
A.6.2 Personal Monitors	A-27
A.7 EME Action Thresholds Summary	A-27
 Appendix B. Soil Resistivity Measurements	 B-1
B.1 Soil Resistivity Variability and Factors Affecting Soil Resistivity	B-1
B.2 Testing Methods	B-4
B.3 Site Preparation Considerations	B-4
B.3.1 Required Test Equipment and Supplies	B-5
B.3.2 Safety	B-5
B.3.3 Performing Soil Resistivity Test	B-6
B.3.4 Interpreting Test Results	B-10

Appendix C. Protecting Against Electrostatic Discharge in Equipment Rooms and Dispatch Centers C-1

C.1 Background Information	C-1
C.2 Equipment Handling And Storage	C-1
C.3 Measures for Controlling Electrostatic Discharge	C-2
C.3.1 Wrist-Straps	C-2
C.3.2 Relative Humidity Control	C-2
C.3.3 Flooring	C-3
C.3.4 Chairs	C-3
C.3.5 Dispatch Position Desktops	C-4
C.3.6 Video Display Terminals	C-4
C.3.7 Equipment Bonding, Grounding, and Surge Protection	C-4
C.4 ESD Control Program	C-4

Appendix D. Grounding (Earthing) Electrode System Testing/Verification D-1

D.1 Overview	D-2
D.2 Prerequisites for Testing	D-2
D.3 Fall-of-Potential Method Testing Procedure	D-4
D.3.1 Test Description	D-4
D.3.2 Required Test Equipment and Supplies	D-4
D.3.3 Preparation for Testing	D-5
D.4 Clamp-On Ohmmeter Testing Procedure	D-13
D.4.1 Test Description	D-13
D.4.2 Required Test Equipment and Supplies	D-14
D.4.3 Preparations for Testing	D-14
D.5 Combining Soil Resistivity Testing with Clamp-On Ohmmeter	D-20

Appendix E. General Conversions and Formulas E-1

Appendix F. R56 Compliance Checklist F-1

F.1 Building Design and Installation	F-1
F.2 External Grounding (Earthing) Electrode System	F-1
F.3 Internal Grounding System	F-3
F.4 Power Sources	F-4
F.5 TVSS	F-5
F.6 Equipment Installation	F-6

Index..... Index-1

THIS PAGE INTENTIONALLY LEFT BLANK.

INTRODUCTION

This manual provides Motorola's guidelines and requirements for the installation of communications equipment, infrastructure, and facilities. This edition of the manual has been updated to reflect recent changes to industry standards referenced throughout the manual..

NOTE: The standards and guidelines in this revision of this manual **shall** apply to **new communication sites** built after the publication date of this revision of the manual. Standards and guidelines in this manual are **not** required to be implemented at sites built prior to publication of this revision.

Users of this manual are cautioned to read and understand all disclaimers on the inside front cover before using this manual.

1.1 COMMITTEE MEMBERS

Committee members for the 2005 edition of the manual are:

- **David Babbitt**, Motorola Northwest Engineering Manager
- **Bob Batis**, National Site Design and Integration Team Manager, Motorola's Government & Enterprise Mobility Solutions
- **Mike Beebe**, Northeast Engineering, System Integration Services, Motorola's Government & Enterprise Mobility Solutions
- **Chris Berbaum**, Lead Systems Engineer, Motorola Network IT Sales
- **Michael Hill**, Programs Manager, Motorola's Government & Enterprise Mobility Solutions
Motorola Australia Pty Ltd
- **Tom Kravcar**, System Support Manager
- **Gene McCurry**, Principal Staff Engineer, National Site Design and Integration Team
- **Shane Morris**, Systems Integration Technical Support Manager
- **Ron Tatom**, Sr. Systems Technologist and R56 Specialist, Systems Integration
- **Mike Tiedt**, Central Systems Engineering, Radio Systems Division, Motorola's Government & Enterprise Mobility Solutions
- **Dan Kelly** (R56 Committee Chairman), National Site Design and Integration Team, Motorola's Government & Enterprise Mobility Solutions

1.2 ORGANIZATION OF THIS MANUAL

This manual is organized into chapters, each of which provides guidelines and requirements for a major aspect of site development. Each chapter contains the following information about the subject it covers:

- Requirements that must be followed. Requirements are indicated by the use of the word "**shall**" in boldface type.

- Guidelines that describe preferred methods, but which are not requirements.
- Useful information about planning, designing, and developing communications sites.
- This manual is a living document. The website shown below will be used to publish manual updates or corrections. After accessing the web site, click View Country, then Documents and Files, Manuals, R56

<http://www.motorola.com/governmentandenterprise/northamerica/en-us/public/functions/viewdownload/viewdownload.aspx?navigationpath=lv1zvviewdownload>

To ask the R56 Committee a question about this manual, use the following email address:

R56MAN1@namerica.mot.com

1.3 SAFETY INFORMATION

1.3.1 SAFETY STATEMENTS DEFINED

Safety statements included in this manual alert you to potential hazards to personnel or equipment, and precede the step or text to which they apply. Safety statements in this manual are of the following types:



WARNING

Warnings indicate danger of injury or death to personnel. Warnings can indicate chemical, electrical, or other type of hazard. Warnings are indicated by an exclamation point and the word WARNING.



CAUTION

Cautions indicate the possibility of damage to equipment. Cautions are indicated by an exclamation point and the word CAUTION.

NOTE: Notes provide information that makes the job or process easier to perform properly.

1.3.2 GENERAL SAFETY GUIDELINES

The following are general safety precautions that must be observed:



WARNING

All Motorola employees and contractors, and other personnel shall be required to use an appropriate EME monitoring device when working in the vicinity of fixed transmission sources of RF energy, unless they are able to conclude clearly that RF energy levels where they are working do not exceed those permitted by applicable standards and regulations. See Appendix A for additional information. Contact Motorola's Site Design and Integration Team for further information on EME awareness and monitors.

- All Motorola employees, contractors, and other personnel working at communication sites **shall** be familiar with the information contained in this manual and **shall** follow the appropriate guidelines.
- To avoid injury or death caused by electric shock, do not wear a grounded wrist strap when working with high-voltage equipment.
- Objects heavier than 18.2 kg (40 lb.) should be lifted by two or more people.
- Before disturbing the surfaces in an existing structure ensure that asbestos is not present. Surfaces containing asbestos can result in an inhalation hazard when disturbed by drilling, cutting, sanding, or demolition. Only certified asbestos abatement professionals **shall** perform asbestos removal. A certificate of occupancy **shall** be secured where such abatement has been performed.
- Personnel performing installation and maintenance should wash their hands before eating and avoid touching mouth and nose while handling equipment and/or debris.
- In environments where explosion hazards may exist, non-incendive intrinsically safe electrical components **shall** be used. Note that certain locations may be entirely unacceptable for housing electronic equipment.
- Communications equipment **shall not** be installed in elevator equipment rooms unless specific, code-allowed measures have been taken to mechanically isolate any wiring from moving equipment.
- All applicable health and safety codes **shall** be followed when performing tasks discussed in this manual.
- Climbing of ladders and towers poses significant safety risks. Only personnel trained in this practice, and who possess the proper equipment **shall** perform such work. The Motorola Contractors Fall Protection Program **shall** be observed.
- Utility locator services **shall** be used to locate buried utilities before conducting any subsurface explorations.
- To ensure personnel safety, all excavations **shall** be conducted in accordance with OSHA safety and excavation regulations, and/or local safety regulations (whichever is more stringent).
- The fire department **shall** be notified as soon as a fire is discovered. Notification **shall not** be delayed in order to assess the results of fire fighting effort using on-site portable fire extinguishers.

WARNING

Do not sweep dry floors when rodent droppings are evident. To prevent hantavirus infection, the floor shall be mopped in a safe and sanitary manner using a 5:1 water/bleach mixture. Personnel working at the site shall wash hands before eating and avoid touching mouth, nose, or eyes until site is sufficiently clean.

WARNING

When operating any kind of power tool, always wear appropriate safety glasses and other protective gear to prevent injury.

- In the United States:
 - all applicable OSHA standards **shall** be adhered to.
 - Ladders **shall** be OSHA approved for electrical work.
 - In installations at nuclear power plants and fuel processing facilities, the laws, rules and regulations of the Nuclear Regulatory Commission (NRC) policy and customer policy **shall** be observed.

1.4 STANDARDS

Table 1-1 lists all published standards cited throughout this manual. All local and jurisdictional codes and safety standards, whether incidental or superseding to standards specified in this manual, **shall** be followed while developing a site, installing equipment, or performing maintenance.

TABLE 1-1 REFERENCED STANDARDS

Publication	Title
ANSI A10.14	Requirements for Safety Belts, Harnesses, Lanyards, and Lifelines for Construction and Demolition Use
ANSI A14	Requirements for Ladders
ANSI C62.1	Surge Arresters For AC Power Circuits
ANSI/ESD S1.1-2001	Evaluation, Acceptance, and Functional Testing of Wrist Straps
ANSI/ESD S4.1-2001	Worksurfaces - Resistance Measurements
ANSI/ESD STM7.1-2003	Floor materials—Resistive characterization of materials
ANSI-J-STD-607-A-2002	Commercial Building Grounding (Earthing) and Bonding Requirements For Telecommunications
ANSI T1-313-2003	Electrical Protection for Telecommunications Central Offices and Similar Type Facilities
ANSI-T1.321-2002	Electrical Protection for Network Operator-Type Equipment Positions

TABLE 1-1 REFERENCED STANDARDS (CONTINUED)

Publication	Title
ANSI T1.333-2001	Grounding and Bonding of Telecommunications Equipment
ANSI T1.334-2002	Electrical Protection of Communications Towers and Associated Structures
ANSI Z308.1	Minimum Requirements For Workplace First Aid Kits
ANSI Z359	Requirements for Personal Fall Arrest Systems, Subsystems and Components
ANSI Z87.1	Occupational And Educational Eye And Face Protection
ANSI Z89.1	Protective Headwear For Industrial Workers -Requirements
ANSI/IEEE 80	IEEE Guide For Safety In AC Substation Grounding
ANSI/IEEE 81-1983	Guide For Measuring Earth Resistivity, Ground Impedance, And Earth Surface Potentials of A Ground System (Part 1)
ANSI/IEEE C95.1	Safety Levels With Respect To Human Exposure To Radio Frequency Energy
ANSI/TIA/EIA-222(f)	Structural Standards for Steel Antenna Towers and Antenna Supporting Structures
ANSI/TIA/EIA-568-A and CSA-T529 (CSA-T529 is the Canadian equivalent of ANSI/TIA/EIA-568-A.)	Commercial Building Telecommunications Cabling Standard
ANSI/TIA/EIA-569-A	Commercial Building Standard for Telecommunications Pathways and Spaces
ANSI/TIA/EIA-606 and CSA-T528	Administration Standard For The Telecommunications Infrastructure of Commercial Buildings (CSA-T528 is the Canadian equivalent of ANSI/TIA/EIA-606.)
ANSI/TIA/EIA-607 and CSA-T527	Commercial Building Grounding and Bonding Requirements for Telecommunications (CSA-T527 is the Canadian equivalent of ANSI/TIA/EIA-607.)
ANSI/UL 154	Carbon-dioxide Fire Extinguishers
ANSI/UL 299	Dry Chemical Fire Extinguishers
ANSI/UL 711, CAN/ULC-S508-M90	Fire Extinguishers, Rating And Fire Testing of
AS 3516.2-1998	Siting of Radiocommunications Facilities – Guidelines for fixed, mobile and broadcasting services operating at frequencies above 30 MHz
ASHRAE	American Society of Heating, Refrigerating and Air-Conditioning Engineers
ASTM 488-90	Seismic anchoring
ASTM A615-68	Specifications for Deformation of Preformed Steel Bars for Concrete Reinforcement
ASTM C150-99a	Standard Specification for Portland Cement
ASTM D1557	Test Method for Laboratory Compaction Characteristics of Soil Using Modified Effort
ASTM D698-91	Test Method for Laboratory Compaction Characteristics of Soil Using Standard Effort
Bellcore Technical Specifications AU-434	Earthquake concrete expansion anchors

TABLE 1-1 REFERENCED STANDARDS (CONTINUED)

Publication	Title
Bellcore TR-64	Concrete specifications for seismic installations
BS 6651:1999	Code of Practice for Protection of structures against lightning
BS 7430:1998	Code of Practice for Earthing
CAN4-S503-M83	Canadian Standard, Carbon-dioxide Fire Extinguishers
CAN4-S504-77	Canadian Standard, Dry Chemical Fire Extinguishers
CSA-T529	Design Guidelines for Telecommunications Wiring Systems in Commercial Buildings, 1995 (harmonized with ANSI/TIA/EIA 569-A)
Code of Federal Regulations 47	Part 17 - Construction, Marking, and Lighting of Antenna Structures
EIA/TIA-222	Tower Foundation and Anchor Design
FAA Advisory Circular 70/7460-1G	Obstruction Marking and Lighting
FAA-STD-019d-2002	Lightning and Surge Protection, Grounding, Bonding and Shielding Requirements for Facilities and Electronic Equipment
FCC/OET RTA 95-01 (NTIS order no. PB95-253829)	Engineering Services for Measurement and Analysis of Radio Frequency (RF) Fields. Technical report for the Federal Communication Commission, Office of Engineering and Technology, Washington, DC
IBC 2000	International Building Code
IEC 60364-1	Electrical Installations of Buildings
IEC 61024-1-2	Protection of structures against lightning
IEEE C62.41	IEEE Recommended Practice on Surge Voltages in Low-Voltage AC Power Circuits.
IEEE C62.45	<i>Guide on Surge Testing for Equipment Connected to Low-Voltage AC Power Circuits</i>
IEEE STD 80-2000	Guide for Safety in AC Substation Grounding
IEEE STD 142-1991 (IEEE Green Book)	<i>Recommended Practice for Grounding of Industrial and Commercial Power Systems</i>
IEEE STD 519-1992	Recommended Practices and Requirements for Harmonic Control in Electrical Power Systems
IEEE Std. 837	<i>Qualifying Permanent Connections Used in Substation Grounding</i>
IEEE STD 1100-1999	Recommended Practice for Powering and Grounding Electronic Equipment
IEEE STD 1159-R2001	<i>Recommended Practice for Monitoring Electric Power Quality</i>
ISO 11271:2002(E)	Soil quality – Determination of redox potential – Field method

TABLE 1-1 REFERENCED STANDARDS (CONTINUED)

Publication	Title
ISO/TC94/SC4	Personal Equipment for Protection Against Falls (International ISO standard)
MIL-HDBK-419A	Grounding, Bonding, and Shielding for Electronic Equipments and Facilities
MIL-STD-188-124B	Grounding, Bonding and Shielding for Common Long Haul/Tactical Communications Systems Including Ground Based Communications Electronic Facilities and Equipments
NEBS TR-63	Network building standard regarding seismic compliance
NECA/BICSI 568-2001	Installing Commercial Building Telecommunications Cabling
NEMA/ANSI Z535.3	Criteria for Safety Symbols
NFPA 1	Fire Prevention Code
NFPA 10	Standard for Portable Fire Extinguishers
NFPA 12	Standard for CO ₂ Extinguishing Systems
NFPA 13	Standard for Installation of Sprinkler Systems
NFPA 17	Standard for Dry Chemical Extinguishing System
NFPA 33	Standard for Spray Application Using Flammable or Combustible Materials
NFPA 70-2005	National Electrical Code® & International Electrical Code® Series
NFPA 101®	Life Safety Code®
NFPA 111	Standard on Stored Electrical Energy, Emergency and Standby Power Systems
NFPA 780-2004	Standard for the Installation of Lightning Protection Systems
NFPA 2001	Standard on Clean Agent Fire Extinguishing Systems
NWSM 30-4106-2004	Lighting Protection, Grounding, Bonding, Shielding, and Surge Protection Requirements
OSHA 1926.104	Safety Equipment
Motorola document 68P09226A18	Frame Mounting Guide
Motorola document 68P81150E62	Grounding Guideline for Cellular Radio Installations
TIA/EIA-222-F-R2003	Structural Standards for Steel Antenna Towers and Antenna Supporting Structures
UL 268	Smoke Detectors For Fire Protective Signaling Systems
UL 467-2004	Grounding and Bonding Equipment
UL 497A	Secondary Protectors For Communication Circuits
UL 497B	Protectors For Data Communication And Fire Alarm Circuits
UL 891	Dead-Front Switchboards
UL 1449	Transient Voltage Surge Suppressors

TABLE 1-1 REFERENCED STANDARDS (CONTINUED)

Publication	Title
ULC-S504-77	Standard for dry chemical fire extinguishers
Uniform Building Code Articles 2330 through 2338 Article 1807 (c), (k), Chapter 23 Article 2370	Earthquake, Seismic Designs High-Rise Buildings Seismic Isolated Structure Design
United States National Weather Service Manual 30-4106-2004	Lightning Protection, Grounding, Bonding, Shielding, and Surge Protection Requirements
ZED 259	Requirements for Personal Fall Arrest Systems (Canadian standard)

1.4.1 AUSTRALIA AND NEW ZEALAND STANDARDS

The following standards publications are applicable for communication sites constructed in Australia and New Zealand.

TABLE 1-2 AUSTRALIAN AND NEW ZEALAND STANDARDS

Publication	Title and Description
ARPANSA RSP 3	<p>Maximum exposure levels to radio frequency fields - 3 kHz to 300 GHz</p> <p>Sets limits for human exposure to radio frequency (RF) fields in the frequency range 3 kHz to 300 GHz. The Standard includes: mandatory basic restrictions for both occupational and general public exposure involving all or part of the human body; indicative reference levels for measurable quantities derived from the basic restrictions; approaches for verification of compliance with the Standard; requirements for management of risk in occupational exposure and measures for protection of the general public.</p>
AS/NZS 1170.1	<p>Structural design actions - Permanent, imposed and other actions.</p> <p>Provides design values of permanent, imposed and other actions to be used in the limit state design of structures and members. It is intended to be used in conjunction with AS/NZS 1170.0. Other actions covered include liquid pressure, ground water, rain water ponding and earth pressure.</p>
AS/NZS 1170.2	<p>Structural design actions - Wind actions</p> <p>Provides design values of wind actions for use in structural design. It is intended to be used in conjunction with AS/NZS 1170.0, which gives the procedure for structural design. Wind speeds and direction factors are provided for a range of probabilities of exceedance. Other factors cover the environment around the structure, the geometry of the structure and the dynamic interaction of the structure with the wind.</p>
AS 1319	<p>Safety signs for the occupational environment</p> <p>Specifies the requirements for the design and use of safety signs intended for use in the occupational environment to regulate and control safety related behavior, to warn of hazards and to provide emergency information including fire protection information.</p>
AS/NZS 1554 (Set)	Structural Steel Welding Set

TABLE 1-2 AUSTRALIAN AND NEW ZEALAND STANDARDS (CONTINUED)

Publication	Title and Description
AS/NZS 1680.2.4	<p>Interior lighting - Industrial tasks and processes</p> <p>Sets out recommendations for the lighting of industrial tasks and processes with a view to providing visual environments in which such tasks and processes may be safely and efficiently performed. It is intended to be read in conjunction with the general recommendations of AS 1680.1.</p>
AS/NZS 1768	Lightning protection
AS 2032	Code of practice for installation of UPVC pipe systems
AS/NZS 2053.1	<p>Conduits and fittings for electrical installations - General requirements</p> <p>Specifies general requirements for both metal and non-metal conduits and fittings to protect cables used in electrical installations. Mechanical properties, electrical characteristics and material requirements are given. Requirements for particular types of conduits and fittings are covered in the other parts of the AS/NZS 2053 series.</p>
AS/NZS 2293.1	<p>Emergency evacuation lighting for buildings - System design, installation and operation</p> <p>Sets out requirements for the design, installation and operation of electric emergency evacuation lighting systems for buildings, so as to provide visual conditions which will alleviate panic and permit safe evacuation of the building's occupants, should this be necessary, in the event of failure of the electrical supply to the normal lighting. Does not specify types of buildings nor particular locations which should be provided with emergency evacuation lighting.</p>
AS 2444	Portable fire extinguishers and fire blankets - Selection and location
AS/NZS 3000	<p>Electrical installations (known as the Australian/New Zealand Wiring Rules)</p> <p>Provides requirements for the selection and installation of electrical equipment, design and testing of electrical installations, especially with regard to the essential requirements for safety of persons and livestock from physical injury, fire or electric shock.</p>
AS 3516.2	<p>Siting of radio communications facilities - Guidelines for fixed, mobile and broadcast services operating at frequencies above 30 MHz</p> <p>Recommends good practice for, and sets out process by which, radio communications sites should be planned, sited, constructed, and operated to meet the communications objectives of those facilities. It particularly addresses the sharing of radio communications sites and interference problems which could arise. It is intended to provide information to Federal, State and local government authorities, facilities planners, site planners, organizations and members of the public on the effects that existing or planned developments could be expected to have on the operation of such facilities, and vice versa.</p>
AS 3600	<p>Concrete structures</p> <p>Sets out minimum requirements for the analysis, design and construction of concrete structures and members that contain reinforcing steel up to 500 MPa, prestressing tendons or both, and includes requirements for plain concrete structures and members. Design requirements are given for the limit states of stability, strength, serviceability, durability and for resistance requirements to fire and earthquakes. Rules are also given for prototype or proof testing of finished members and structures.</p>
AS 3610	Formwork for concrete

TABLE 1-2 AUSTRALIAN AND NEW ZEALAND STANDARDS (CONTINUED)

Publication	Title and Description
AS 3995	Design of steel lattice towers and masts
AS 4100	Steel structures Sets out minimum requirement for the design, fabrication, erection, and modification of steelwork in structures in accordance with the limit states design method.
AS/NZS 4117	Surge protective devices for telecommunication applications
AS/NZS 4680	Hot-dip galvanized (zinc) coatings on fabricated ferrous articles
AS/NZS 60950	Safety of information technology equipment (IEC 60950:1999, MOD) Specifies requirements for the safety of information technology equipment including electrical business equipment and associated equipment, with a rated voltage not exceeding 600V. Specifies requirements intended to ensure safety for the operator and layman who may come into contact with the equipment and, where specifically stated, for service personnel. This Standard is an adoption with national modifications and contains the whole text of IEC 60950:1999.
SAA HB37.4	Handbook of Australian Fire Standards - Building materials, products and construction
ACA TS 001	Safety Requirements for Customer Equipment Defines the safety requirements for Customer Equipment (CE) with the objective of providing protection of the CE users from electrical supply hazards, protection of the CE user from telecommunications network hazards, protection of telecommunications network personnel from connected CE hazards, and protection of a telecommunications network from harm arising from connected CE (both mains powered and non-mains powered).
AS/ACIF S008	Requirements for authorised cabling products
AS/ACIF S009	Installation requirements for customer cabling

1.4.2 STANDARDS ORGANIZATION WEBSITES

Internet sites for some major regional Standards organizations are listed below for reference.

Country/Region	Website
Australia	http://www.standards.com.au
Britain	http://www.bsi.org.uk
Canada	http://www.csa-international.org
China	http://www.sac.gov.cn
Europe	http://www.etsi.org

Country/Region	Website
France	http://www.afnor.fr
International	http://www.iec.ch
International	http://www.standards.ieee.org
International	http://www.iso.org
Japan	http://www.jsa.or.jp
Malaysia	http://www.sirim.my
New Zealand	http://www.standards.co.nz
Singapore	http://www.spring.gov.sg
United States:	http://www.ansi.org
• Electrostatic Discharge Association website	http://www.esda.org/aboutesd.html
• FCC Office of Engineering and Technology (RF safety).	www.fcc.gov/oet/rfsafety
• United States Geological Survey Geological Hazards Team	http://geohazards.cr.usgs.gov
• United States Geological Survey (Earthquake Hazards Program)	http://neic.usgs.gov/neis/states/
• United States Geological Survey home page	http://www.usgs.gov

1.5 GLOSSARY

This section provides definitions of terms and acronyms used in this manual.

ACI: American Concrete Institute.

ACS: Advanced Conventional Systems.

ADSL: Asymmetric Digital Subscriber Line.

AEB: See Ambassador Electronics Bank.

AH: Ampere Hours.

Ambassador Electronics Bank: A central switch that routes and combines all audio sources for SmartZone trunking systems. Also known as Embassy Switch or AEB.

Ambient Temperature: Environmental temperature as typically measured 610 mm (5 ft.) above the floor in the center of an aisle.

Ampere Hours: A measurement of battery current capacity relative to time, normalized to 8 hours. For example, a 320 Ah battery will deliver 40 Amperes for 8 hours.

ANSI: American National Standards Institute.

Antenna: A device that permits transmission and reception of radio frequency energy through space. Also known as aerial.

Antenna Structure: Generic term describing an antenna supporting system which may be other than a tower (building, monopole, bracket, etc.).

Approved: Acceptable to the authority having jurisdiction.

As-Built: A Motorola factory-provided printout furnished with a new system or site development that describes the system's or sites original factory-built or installed configuration.

ASHRAE: American Society of Heating, Refrigerating, and Air Conditioning Engineers.

ASSE: American Society of Safety Engineers.

ASTM: American Society for Testing of Materials.

Attenuator: A passive device for controlling (attenuating) signal levels. It can be fixed, calibrated, or variable. Where calibrated attenuators are used, the device is typically calibrated in dB of negative gain (loss or attenuation).

Authority Having Jurisdiction: The local governing body.

AWG: : American Wire Gauge: An American standard for identifying the thickness of electrical conductors.

Bandpass Cavity: A high Q resonant circuit designed to pass a narrow band of frequencies with very little loss while attenuating all other frequencies outside the selected bandwidth. When used between a transmitter and the antenna transmission line, it reduces spurious signals and transmitter sideband noise that might otherwise be radiated from the transmitter and degrade the performance of a nearby receiver.

Bandwidth: The frequency spectrum space occupied by a signal of a single channel.

Base station: 1) Station that allows simplex communications between radio units and console positions. 2) A repeater which provides the source of audio received by the console, and the destination of audio transmitted from the console.

Battery: One or more electrochemical storage cells connected together to serve as a DC voltage source.

Blackout: An extended zero-voltage condition (total loss of power) lasting for minutes, hours, or even days at a time. Blackouts can be caused by ground faults, accidents, lightning strikes, power company failures, or other acts.

BNC: Bayonet "N" Connector.

BOCA: Building Officials and Code Administrators International, Inc.

Bonding: The permanent joining of metallic parts to form an electrically conductive path that ensures electrical continuity and the capacity to safely conduct any current likely to be imposed.

Bonding jumper: A reliable conductor that ensures the required electrical conductivity between metal parts required to be electrically connected.

Boot: A protective, flexible sleeve installed around cables that pass through the wall of a communications site building.

Branch circuit: The circuit conductors between the final overcurrent device protecting the circuit and the outlet(s).

British Thermal Unit: A standard measurement of generated energy, typically as heat. (1 BTU equals 1.055 kJoules of energy.)

Brownout: A long-term under-voltage condition lasting minutes, hours or even days at a time. They are often intentionally instituted by an electric utility company when peak demand exceeds generating capacity.

BTU: British Thermal Unit.

Building: For the purposes of this manual, a permanent structure capable of regular human occupancy built on a foundation that contains communications equipment and related ancillary support systems, and may contain other unrelated equipment and/or facilities.

Cabinet/enclosure: An enclosure that houses communications equipment and ancillary systems only. It is designed such that equipment contained within can be accessed without the need for personnel to enter the cabinet.

Cable ladder: An open steel structure (painted or anodized) suspended from the ceiling that provides an orderly means of support and routing for wires and cables throughout a communications site. May be installed inside the building or vertically to guide cables on a tower. All exterior cable ladders should be constructed of galvanized metal. See Cable runway.

Cable runway: A structure provided for the routing and management of cabling. May be located below a raised floor, suspended from the ceiling, or mounted on top of equipment racks and/or cabinets. The term Cable Runway is used in this manual to include both cable ladders and cable trays.

Cable tray: A solid structure, typically constructed of aluminum or fiberglass, suspended from the ceiling that provides an orderly means of support and routing for wires and cables throughout the interior of a communications site. See Cable runway.

Caisson: A drilled cylindrical foundation shaft used to transfer a load through soft soil strata to firm strata or bedrock. The shaft is filled with either reinforced or unreinforced concrete. A caisson may either be a straight shaft or bell type of installation.

CATV: Cable Television.

CCTV: Closed-Circuit Television.

CEB: Central Electronics Bank

Cellular: A multi-site, low-power full-duplex radio system that interfaces to the PSTN.

Central Electronics Bank: Electronic equipment that provides the interface between the console dispatch positions and the RF equipment (CEB).

Central Office: The main switching center of a telephone service provider or local exchange carrier (LEC).

CEPT: European Committee of Post and Telegraphs.

CFC-free: Denotes a refrigerant which does not use chlorofluorocarbons.

CFR: Code of Federal Regulations.

Channel bank: A device that places multiple channels on a digital or analog carrier signal.

Channel Service Unit: A digital DCE used to terminate digital circuits (such as DDS or T-1 lines) at the customer site. It conditions the line, ensures network compliance with FCC rules, and responds to loopback commands from the central office.

CIU: Console Interface Unit.

CO: Central Office.

Combiner: A passive device that allows transmitters on different frequencies to use a single antenna.

Console: A system's dispatch electronics, made up of one or more console operator positions and a Central Electronics Bank (CEB).

Console Interface Unit: An interface device that provides encryption/ decryption of console audio signals.

Conventional system: A radio system in which resources are dedicated to a specific frequency.

CPR: Cardio-Pulmonary Resuscitation.

Critical Loads: Devices and equipment whose failure to operate satisfactorily jeopardizes the health or safety of personnel, and /or results in loss of function, financial loss, or damage to property deemed critical by the user.

CSA: 1) Abbreviation for Canadian Standards Association. 2) Cross-sectional area (as used for cable gauge specification in metric system).

CSI: Construction Specification Institute.

CSU: Channel Service Unit.

Daisy chain: Any method of connection whereby the conductors are connected from one chassis, equipment frame or rack connection point to a second chassis, equipment frame or rack connection point and on to a third connection point, creating a series arrangement whereby the removal of the second connection point interrupts the ground path from the first chassis, equipment frame or rack. Daisy chaining of grounding conductors is not an acceptable method of connection.

Demarcation Point: The telephone or utility point of presence at a facility which divides utility assets from customer assets and accordingly assigns maintenance responsibilities.

Dip: See "Sag." Dip is the International Electrotechnical Commission (IEC) term for sag.

Distortion: Any deviation from the normal sine wave for an AC quantity.

DOT: Department of Transportation.

Duplexer: An RF filtering system that separates the transmit and receive frequency, so that equipment can transmit and receive simultaneously on a single antenna, without affecting other equipment.

DVM: Digital Voltmeter.

E-1: A time division multiplex (TDM) digital link which uses 32 time slots with a speed of 2.048Mb/s

Earth; Earthing: Synonymous with ground; grounding.

EAS: Environmental Alarm System.

Easement: An interest in real property which is owned by another that entitles the holder to a specific limited use or enjoyment of the owner's property.

EBTS: Enhanced Base Transceiver System.

Effective Radiated Power: The near-field radiated effective power (as opposed to peak envelope power) of a transmitting antenna. Specifies power radiated less any losses inherent in transmission lines or antenna coupling.

EGB: External Ground Bus Bar.

EHS: Environmental Health and Safety.

EIA: Electronics Industries Association.

Electrolytic ground rods: Ground rods in which the ability to dissipate charge is enhanced by chemical reaction with the soil.

Electrical Metallic Tubing: Describes conduit tubing used specifically for housing electrical conductors. Several variations are available for specific purposes.

Electrostatic Discharge: A high voltage, low current electrical discharge caused by buildup of static charge between two surfaces.

EME: Electromagnetic Energy.

EMT: Electrical Metallic Tubing.

Enhanced Base Transceiver System: Base stations used in the iDEN system.

Environmental Alarm System: Equipment which centrally receives, interfaces, and processes remote alarms related to equipment environmental conditions and other switch-closure alarms.

ERP: Effective Radiated Power.

ESD: Electrostatic Discharge.

Ethernet: A Local Area Network (LAN) protocol.

ETSI: European Telecommunications Standards Institute.

Exothermic welding: A process by which two pieces of metal are permanently welded using heat generated by a chemical reaction caused by combining the welding materials.

External Ground Bus Bar: A ground bus bar that provides a bonding point for multiple grounding conductors (such as all coaxial connections) and connection to the grounding electrode system.

External grounding system test: A test that measures the effective resistance of the external site grounding system.

External site grounding ring: A ring of conductor wire surrounding an equipment enclosure, building and tower at a communications site. The grounding ring is bonded to the grounding electrodes, so that electrical charges are ultimately dissipated by the earth.

FAA: Federal Aviation Administration.

Fair Market Value: The approximate worth of a piece of property, based on several factors including location and the actual selling price of similar properties in the area.

Facility: A complete site environment, including power system(s), site structure, HVAC system, antenna structure, and boundary fencing (if applicable).

Failsoft: A default communication mode for trunking systems that prevents system shutdown by providing limited communications capability during a system failure. The repeaters operate in conventional mode if the central controller fails.

FCC: Federal Communications Commission.

Federal Aviation Administration: The US regulatory agency responsible for air traffic safety. It also governs height and marking regulations for towers and other tall structures that could pose a hazard to aircraft.

Federal Communications Commission: The US regulatory agency responsible for overseeing radiated transmissions in the United States.

Firestop: A cross-member used in walls to inhibit vertical spread of fire.

Fixed Network Equipment: Permanently installed communications site infrastructure equipment.

FM: Factory Mutual.

FMV: Fair Market Value.

FNE: Fixed Network Equipment.

FOTS: Fiber Optic Transmission System.

Frequency Deviation: An increase or decrease in the power frequency from nominal. The duration of a frequency deviation can be from several cycles to several hours (IEEE STD 1100-1999 and IEEE STD 1159-R2001).

FRU: Field Replaceable Unit.

GFCI: Ground Fault Circuit Interrupting.

Gin pole: Construction equipment used for lifting tower sections and antennas during antenna construction.

Global Positioning System (GPS): A system which determines exact locations by utilizing high-precision satellite signals as its reference. The satellite signals can also be used as a timing reference.

Ground Fault Circuit Interrupting (GFCI): A type of electrical receptacle that removes power to the receptacle if a ground fault occurs in the equipment connected to the receptacle.

Grounding: The connecting of a particular leg of a circuit across multiple equipment of a power system in common. The common connection is then also electrically bonded to the soil. In this manner, the grounded portion of the circuit can serve as a common low-side connection across the system. Synonymous with earthing.

Grounding conductor: A means for bonding equipment to the site grounding electrode system.

Grounding electrode system: A buried system of ground conductors which provides a bonding point between soil grounding at the site and the neutral-ground connection of the incoming AC power. The site master ground bar is also bonded to this point.

Ground loop: A potentially detrimental loop formed when two or more points in an electrical system that are normally at ground potential are connected by a conducting path such that either or both points are not at the same ground potential.

Ground test well: A buried port that allows inspection of connections to the grounding electrode system.

Gumbo: A soil composed of fine-grain clays. When wet, the soil is highly plastic, very sticky, and has a soapy appearance. When dried, it develops large shrinkage cracks.

Hantavirus: A potentially deadly airborne virus spread by rodents.

Hard-wiring: The practice of direct physical connection of wiring leads directly to a junction device. An example of hard-wiring is the connection of a device's AC line directly to a junction box without the use of a receptacle and line cord.

Harmonic: Regarding power lines, an abnormality in which distortion of the normal utility sine wave occurs. Harmonics can be transmitted back into an AC power line by non-linear loads such as switching power supplies and variable speed motors. If significant enough, harmonic conditions can cause overheating in step-down and three-phase load transformers and neutral conductors.

Hazardous Material Identification System: A labeling system for identifying the location of potentially hazardous materials.

HAZMAT: Hazardous Material(s).

Hertz: Frequency measurement unit abbreviated as Hz. One Hz equals one cycle per second.

HMIS: Hazardous Material Identification System.

HVAC: Heating, Ventilation and Air Conditioning equipment.

Hz: Hertz.

ICBO: International Conference of Building Officials.

Ice bridge: A protective shield for horizontal cable runs between towers and building cable entry ports or between two buildings, designed to prevent ice from forming and falling on the cables during winter.

iDEN: Integrated Dispatch Enhanced Network.

IEC: International Electrotechnical Commission

IEEE: Institute of Electrical and Electronics Engineers.

IGZ: Isolated Ground Zone.

Integrated Dispatch Enhanced Network: A Motorola-manufactured digital transmit/receive system, operating in the 800-900 MHz range, that combines radio and telephone services in a single subscriber unit.

IPGB: Internal Perimeter Ground Bus conductor.

Isolated Ground Zone: An installation configuration where grounding of equipment is electrically isolated and/or separate from general facility grounding.

ITU: International Telecommunications Union. (Also known as CCITT.)

IZGB: Isolated Zone Ground Bar.

Let-through Voltage: Voltage (at a specified current) allowed through a TVSS device when the device is in suppression mode.

Low Pass Filter: Also referred to as “harmonic filter”. Filter that suppresses harmonic frequencies above its specified pass band. It is used with transmitters to prevent intermodulation. Most systems require this type of filter between the isolator and the antenna system to reject second and third harmonic transmitter energy.

LPG: Liquefied Propane Gas.

LTV: Let-through Voltage.

LVLVD: Low-Voltage Load Disconnect.

Master Ground Bus Bar: The single grounding point inside an equipment enclosure to which all other interior ground wires are ultimately bonded. There is one master ground bus bar per building or equipment area at a communications site.

Material Safety Data Sheet: A manufacturer-provided ingredient and safety hazard description of materials classified as hazardous or containing hazardous elements. It also includes information for handling spills or chemical reactions.

Maximum Permissible Exposure: Defines maximum permissible exposure to radiated RF energy to personnel. Several levels exist based upon frequency, power density, and time of exposure.

Metal-Oxide Varistor: A two-terminal voltage protection device in which resistance across the device markedly decreases when the voltage across the device reaches a specified threshold.

Meter pedestal: The base structure for the electric services utility meter at communications site. Typically installed by the local utility company during communications facility construction.

MGB: Master Ground Bus Bar.

Microwave: Frequencies higher than one GigaHertz (1,000,000,000 Hz) in the frequency spectrum.

Mobile Switching Office: Provides central office functions for iDEN mobile units.

Modified Proctor test: A soil compression test that measures the compacted density of soils being used for structural applications. (See ASTM D1557 for additional information.)

MOV: Metal-Oxide Varistor.

MPE: Maximum Permissible Exposure.

MSDS: Material Safety Data Sheet.

MSO: Mobile Switching Office.

MTBF: Mean Time Between Failures.

Multicoupler: An RF device which provides multiple outputs of a single RF input.

Multimeter: A test instrument capable of measuring voltage, current, and resistance.

National Electrical Code: A consultative organization responsible for electrical practices standards. It is part of the National Fire Protection Association (NFPA).

NEBS: Network Equipment Building Systems.

NEC®: National Electrical Code.

Network Interface Unit: A T-1 network interface unit.

NCRP: National Council for Radio Protection and Measurement.

NEMA: National Electrical Manufacturers Association.

NFPA: National Fire Protection Association.

NIU: Network Interface Unit.

Noise: Regarding line power, a power line abnormality which collectively refers to various kinds of high frequency impulses that ride on the normal sine wave of AC electrical power. Noise can range from a few millivolts to several volts in amplitude and can create erratic behavior in any electronic circuit. RF noise, when present over power lines, is one of the more troublesome. This noise can be generated by lightning, radio transmissions, or computer power supplies.

Nomograph: An arrangement of axes in which a variable is determined by a line which intersects known points on associated axes.

Non-Linear Load: Steady-state electrical load that draws current discontinuously or whose impedance varies throughout the cycle of the input AC voltage waveform (IEEE STD 1159-R2001).

Notch Filter: A band-reject cavity filter designed with a high Q resonant circuit to attenuate a narrow band of frequencies while allowing all other frequencies to pass through with only a slight loss of signal strength.

NRC: Nuclear Regulatory Commission

Operating Temperature: Temperature within an equipment case, with the equipment operating at a given capacity or load.

ORV permit: Off-road vehicle permit. A permit that grants the holder the right to drive a motorized vehicle through areas inaccessible by road.

OSHA: Occupational Safety and Health Administration: United States federal government regulatory agency responsible for standards regarding personnel safety at commercial and industrial sites.

Paging: A one-way communication system in which the receiving unit is sent a digital message. Paging can be provided as a PCS service.

PANI: Surge energy Producers, Absorbers Non-isolated equipment and Isolated equipment. A method of bonding conductors to the MGB in a specific order, depending on their origin.

PCS: Personal Communication Services.

Personal Communication Services: A digital communications system that provides data services such as messaging and paging as well as digitized voice.

PERT chart: Program, Evaluation, and Review Technique chart. A flowchart showing the relationship and sequence of events comprising a project.

Plat book: A document that depicts the legal ownership of specific parcels of land, usually in relation to a county, township, section, or range.

Plenum: A compartment or chamber to which one or more air ducts are connected and that forms part of the air distribution system.

Point of entrance: The point of emergence through an exterior wall, a concrete floor slab, or from a rigid metal conduit or an intermediate metal conduit effectively bonded to a ground electrode system.

Pulse method: A method for tower guy wire tensioning.

PSTN: Public Switched Telephone Network.

QA/QC: Quality Assurance/Quality Control.

R56: The Motorola committee responsible for enacting standards related to communication site construction and installation practices. R56 also refers to the literature distribution number formerly used for this manual, Standards and Guidelines for Communications Sites (PN 68P81089E50).

Rack: A standard equipment rack used for supporting communications equipment installed in an existing Building or Shelter.

Rack Ground Bus Bar: A single bus bar to which all equipment ground wires are bonded within a single equipment rack.

RF: Radio Frequency.

RFDS: RF Distribution System.

RFP: Request For Proposal.

RF Distribution System: A system that combines RF signals so that multiple transmitters and receivers tuned to different frequencies can use a single antenna.

RGB: Rack Ground Bus Bar.

RH: Relative Humidity.

RMS: Root-Mean-Square.

R-Value: A standardized rating system of thermal insulation effectiveness. Higher values denote greater insulating effectiveness.

SAD: Silicon Avalanche Diode.

Safety climb: Equipment that is attached to a tower to safely enable tower climbing.

Sag: A root mean square (RMS) reduction in the AC voltage, at the power frequency, for durations from a half cycle to a few seconds (IEEE STD 1100-1999). (see also Swell). It is a multi-cycle, under-voltage condition that can be caused by ground faults, undersized power systems, lightning, or a sudden start-up of a large electrical load. The IEC terminology for sag is “dip.”

SBCCI: Southern Building Code Congress International, Inc.

Seismic rating: Any of several standardized systems of rating an area's probability and intensity of seismic activity based on geological and empirical data. This publication references the Moment Magnitude (MM) rating standard recognized by the Uniform Building Code. Ratings of “0” (least probability with the least intensity) through “4” (greatest probability with the greatest intensity) are accordingly assigned to various regions.

Separately Derived System: A premises wiring system in which power is derived from a transformer or converter winding. It has no direct electrical connection, including a solidly connected grounded circuit conductor, to the supply conductors originating in another system.

Service Entrance: The point at which the utility enters a facility and the utility ground rod is attached.

Shelter: A Permanent structure built on a foundation that contains communications equipment and related ancillary support systems, and may contain other unrelated equipment and/or facilities. A Shelter **shall** be suitable for temporary human occupancy during equipment installation, maintenance, and use.

Silicon Avalanche Diode: A two-terminal voltage protection device in which resistance across the device markedly decreases when the voltage across the device reaches a specified threshold.

Simulcast: A system configuration using simultaneous transmissions of information on the same frequencies. This configuration extends communications over a large coverage area. Each repeater on the same frequency has identical transmit parameters to ensure the intended transmission format.

SPD: Surge Protection Device

Swell: An increase in RMS voltage or current at the power frequency for durations from 0.5 cycles to 1.0 minute (IEEE STD 1100-1999 and IEEE STD 1159-R2001).

TETRA Terrestrial Trunked Radio

Total Harmonic Distortion (THD): The ratio of the root square value of the harmonic content to the root square value of the fundamental quantity, expressed as a percent of the fundamental (IEEE STD 1100-1999).

Transient: A sub-cycle disturbance in the waveform that is evidenced by a sharp, brief discontinuity of the waveform. May be either polarity and may be additive to, or subtractive from, the nominal waveform (IEEE STD 1100-1999). See IEEE STD 1159-R2001, *Recommended Practice for Monitoring Electric Power Quality*, section 4.4.1 for more details on transient definitions, types, and causes.

TVSS Transient Voltage Surge Suppressor

VSWR Voltage Standing Wave Ratio

THIS PAGE INTENTIONALLY LEFT BLANK.

SITE DESIGN AND DEVELOPMENT

This chapter provides requirements and guidelines for site design and development. Site development refers to the civil, structural, mechanical, and electrical work; and installation of supporting equipment at a communications site. The chapter primarily discusses new site construction. Adding onto an existing site or installing a site in an existing facility requires that the scope of work, design and drawings be specific to these locations. It is recommended to consult with Motorola's Site Design and Integration Team for new construction, co-location and renovation work.

This chapter contains information on the following topics:

- “Compliance with RF Energy Exposure Standards” on page 2-1
- “General Outline of Work” on page 2-2
- “Planning” on page 2-3
- “Constructability Review” on page 2-7
- “Electrical Service” on page 2-10
- “Foundation Design and Installation” on page 2-11
- “Concrete and Soils Installation Monitoring” on page 2-14
- “Site and Facility Acceptance Testing” on page 2-16
- “Tower Design and Construction” on page 2-16

The design and development of communications sites is critical not only to optimal functioning of the communications system, but also to the safety of installation and maintenance personnel involved with building and maintaining the system. The importance of implementing and following safety programs, during construction as well as during the system's useful life, cannot be overemphasized.

All final construction drawings and specifications for a new site should be provided by a properly licensed engineering firm. This ensures that the design is adequate for the site conditions and helps ensure that accurate records of site construction are available.

2.1 COMPLIANCE WITH RF ENERGY EXPOSURE STANDARDS

In planning, installing, or modifying any antenna tower or other antenna site, the need to comply with regulations and standards concerning human exposure to RF energy must be considered. Factors to be considered include (1) the location, direction, transmission power, frequency, physical characteristics, and design of all antennas and other equipment at the site, in light of the existing or possible human occupation or usage of the adjacent areas; (2) any necessary and appropriate steps to limit or control human access to adjacent areas, including limited-access doors, fencing, signs, and training; and (3) appropriate operational procedures to ensure ongoing compliance with RF energy exposure regulations and standards when the antenna site is operational.

There should be a clear determination of who will be responsible for each aspect of compliance assurance, with the understanding that the operator or site owner bears ultimate responsibility for compliance. Additional information is provided in Appendix A.

NOTE: All work **shall** conform to applicable codes and regulations imposed by authorities having jurisdiction.

All contractors performing work at a site and all equipment vendors must be competent and qualified. A list of qualified contractors resides with the Motorola's Site Design and Integration Team and the Motorola Environmental Health and Safety (EHS) director.

2.2 THE MOTOROLA SITE DESIGN AND INTEGRATION TEAM

The Motorola Site Design and Integration Team (SD&IT) was developed to provide consistent and cost effective design and construction solutions utilizing key personnel with vast experience, expertise and knowledge in the public safety and construction arenas. The SD&IT key areas of expertise include, but are not limited to, site acquisition and leasing, zoning, architectural, engineering and environmental services, construction management, site preparation, site construction (including tower foundation and tower erection), co-location (including water tower and roof-top applications), outdoor cabinets and tenant build-outs. The Motorola SD&IT will be involved on a nationwide basis for all projects that involve any of the above stated activities. Motorola Site Design and Integration Team contacts will be available on the internal and external R56 websites. Additionally the SD&IT will own the responsibility for this R56 manual and its encompassing services.

Contact information for the National Site Design and Integration Team:

- Site Development, A&E or Site Acquisition Questions: **Bob Batis** (989) 224-1330
- Product Questions: **Gene McCurry** (770) 673-5009
- Questions about this manual: **Dan Kelly** (708) 687-3224

2.3 GENERAL OUTLINE OF WORK

The following is a high-level overview of major site development tasks and the order in which they are typically performed.

- Planning and site design drawing preparation
- Site surveying/staking
- Constructability review
- Installing temporary facilities if necessary
- Clearing land of vegetation
- Installing erosion control barriers
- Excavating and building access road
- Installing utility/electrical metering base
- Excavating and establishing subgrade and drainage requirements
- Excavating and installing shelter and any ancillary foundations

- Excavating and installing tower foundations
- Installing equipment shelter and ancillary equipment, including backup power systems
- Installing electrical conductors and other utility installations
- Energizing equipment shelter
- Installing tower, antennas and RF transmission lines
- Installing tower lighting system
- Installing fencing and gates
- Backfilling, grading, and bringing site up to final grade
- Startup and testing of facility equipment
- Performing final cleanup and obtaining customer approval signatures

2.4 PLANNING

Planning the development of a communications site is crucial because the activities involved in constructing a site must be effectively organized in order to complete the project efficiently.

2.4.1 LOCATION OF UTILITY ENTRANCES

All utility entrances (i.e., AC power, phone company, RF cables, water supply, gas supply, etc.) to the facility should be located in the same general area of the shelter and should be located as close together as is practical.

2.4.2 LOCATION OF AC POWER NEUTRAL-GROUND BOND

Equipment performance and the susceptibility of a communications site to damage from lightning are affected by the location of the AC power neutral-ground bond. See “Location of Neutral-Ground Bond” on page 6-4.

2.4.3 SITE DEVELOPMENT DRAWINGS

To help ensure that site development plans are developed in accordance with jurisdictional codes and specifications, it is highly recommended that an engineering firm be consulted.

Typical site development drawings should include (but not be limited to) the following:

- General compound and site layout relative to the surroundings
- Location of access road if applicable
- Location of existing utilities
- Road profiles (cut and fill requirements)
- Existing road profile

- New road profile depicting road grade. Attempt to achieve a grade of less than 10%. Cranes, concrete trucks, and other heavy construction or delivery shipments must have access to the site.
- True North/South and East/West Construction baselines as represented from the tower center (or center of site structure).

NOTE: For guyed towers, it is imperative that the final elevation of the anchor head and final grade be coordinated between the foundation tower designer and site engineering firm.

- Guy anchor location data schedule (if applicable). Typically the bottom of an anchor head should be 305 mm (12 in.) to 457 mm (18 in.) above final grade.
- Foundation Plan, including general layout of all required foundations and foundation schedule depicting applicable foundation elevations
- Grading Plan showing general grade elevation and slope of compound and access areas
- Sediment Control Plan showing location of hay bales or silt fences to prevent soil erosion
- Grounding system design showing all typical exterior grounding requirements. Soils resistivity measurements may also be depicted.
- Typical access road cross section and culvert detail, showing the following:
 - Cross section of access road
 - Drainage requirements
 - Curb cut requirements
- Equipment Shelter Foundation and details, showing the following:
 - Foundation layout (depth, length, and width of all foundations)
 - Cross-sectional view of foundations for rebar placement
- Utility plan and installation details, showing the following:
 - Layout and installation routes for required utilities
 - Types of instrumentation required if applicable
 - Electrical one-line and service installation details, showing electrical service installation.
- Telephone Installation Details, showing type of telephone line installation if required
- Fence enclosure and guy anchor fence plan showing fencing installation

2.4.4 LAND SURVEY AND SITE DEVELOPMENT STAKING CONSIDERATIONS

Prior to finalizing site development plans, the site surveying firm should supply the following items as a minimum:

NOTE: Topographic and property boundary surveys **shall** be signed and sealed by a Registered Professional Engineer (or as required by jurisdictional law).

- Electronic (in compatible software version) and paper copies of property boundary surveys, clearly showing all easements, rights-of-way and boundaries. The property survey should be overlaid on the topographic survey to show property boundaries with respect to surface conditions.
- Electronic (in compatible software version) and paper copies of topographic surveys showing all relevant surface conditions and characteristics, ensuring proper contour lines to convey relative surface height or depth.
- East/West and North/South construction baseline delineation.
- Latitude, longitude and elevation of proposed center of tower in relation to the communication compound.

Site development staking should be performed upon completion of site development plans and required approval. It is recommended that site development staking be performed by the original surveying firm. The contractor performing the fieldwork and the surveyors should have a kickoff meeting to set expectations, understand and agree to a process that ensures timely execution.

Electronic and paper copies of the completed construction drawings **shall** be transmitted back to the surveyor, to minimize the chance for errors in determining property boundary encroachment or engineering errors. At a minimum site development staking should include (but not be limited to):

- Easement/right of way locations
- Temporary easement locations
- Temporary and permanent roadways
- Roadway curb cut and radius locations
- Center of tower
- Site fence corners
- Center of tower leg locations
- Building foundation corners
- Center of inner and outer guy anchor locations

2.4.5 TEMPORARY FACILITIES

The following items are typically required during construction. Plan for these items before construction begins so they will be available when needed.

- Staging, fabrication and construction areas
- Drives, walks and bridges
- Public access
- Telephone
- Sanitary and cleanup facilities
- Drinking water
- Light and power
- Heat
- Enclosures and storage

- Dumpsters and trash removal services (do not burn trash onsite.)
- Restrictions on access to equipment shelter (do not use shelter as a workshop)
- Personnel and tool trailers

2.4.6 GEOTECHNICAL CONSIDERATIONS

Geotechnical investigations are required for all projects that involve subsurface foundation installations, engineering design parameters and other related aspects of site development. Geotechnical data obtained in these investigations **shall** be provided to the tower and foundation designers and site engineering firm in a compatible electronic format.

Unless otherwise specified, tower foundation and anchor design **shall** be executed in accordance with the latest revision of ANSI/EIA/TIA-222 (or other applicable local Standards body design requirements). It is highly recommended that the customer, tower and foundation designer, site-engineering firm and the appropriate Motorola representative hold a meeting to set expectations, requirements, parameters and the approval process to ensure timely completion of the designs.

NOTE: Some contracts and geographical locations may require additional geotechnical information. Consult a reputable geotechnical firm, and the tower and foundation designer to ensure that all required geotechnical information is included in the report.

- Normal soil **shall** be defined as a cohesive type soil with:
 - a vertical bearing capacity of $19,530 \text{ kg/m}^2$ (4000 lb/ft^2)
 - a horizontal bearing capacity of $1,953 \text{ kg/m}^2$ per 300 mm (400 pounds per square ft. per lineal ft.) of depth to a maximum of $19,530 \text{ kg/m}^2$ (4000 lb/ft^2).
- Rock, non-cohesive soils, or saturated or submerged soils **shall not** be considered normal.
- Pocket penetrometer tests should not be substituted for unconfined compression tests.
- For each layer of soil encountered, the following items should be determined by field or laboratory testing and summarized in the soils report depending on the types of foundations recommended.
 - Standard penetration values
 - Soil classification and elevations
 - Angle of internal friction
 - Unconfined compression strength and cohesion
 - Tension and compression skin shear (for piles, caissons or drilled piers)
 - In-situ soil density and moisture content
 - Expected ground water fluctuations
 - When drilled piers are feasible, the plasticity index and over-consolidation ratio **shall** be determined.
 - The recommended type(s) of foundations to be considered, and corresponding design parameters for uplift, compression and lateral load
 - Construction techniques to ensure the design parameters are obtained.

2.5 CONSTRUCTABILITY REVIEW

The constructability review leverages construction knowledge and experience in planning, design, procurement and field operations to achieve overall project objectives. All project parties should become involved in a constructability program at the onset of a project to ensure there is a maximum influence on overall cost, quality, cycle time and functionality. Outlined below are some of the basic steps for a constructability review.

- Establish criteria for selection of members
- Establish constructability objectives/concepts
- Establish project objectives (scope) relative to constructability objectives
- Compare contractual scope objectives and constructability objectives with requirements of this manual
- Establish roles and responsibilities
- Establish the importance of teamwork
- Determine level of formality for constructability program
- Define specific constructability procedures
- Integrate constructability into project activities
- Identify appropriate measures for objectives

2.6 SITE WALKS

As defined here site walks refer to post contract award. Site walks familiarize involved parties with the development plan for a proposed site. After a site's use has been confirmed, a site walk **shall** be conducted to examine as much detail about the site as possible, and to clearly determine and describe responsibility for all aspects of the site development. It is recommended where practical that all involved parties participate in a site walk. This includes but is not limited to geotechnical, site engineering, the site design team or site design team designee, contractor, and the customer personnel. This saves time, encourages multiple opinions, and ensures that all parties agree on preliminary layouts.

At a minimum, the following items should be completed during the site walk:

- Choose the specific location of the facility. (If survey information is not available or applicable, precise location information is required for future reference and equipment deliveries).
- Note general condition of site and surrounding area, including pre-existing flooding or erosion conditions. Note site characteristics and any notable items from the surrounding properties.
- Discuss site layout. General agreement and concurrence should be reached on preliminary site layout and development with respect to the site and its characteristics.
- Verify the location of the nearest commercial utility/electrical service. If available, note the name of the service provider along with a service pole number or approximate location of nearest service pole.
- Observe accessibility. Access to the site is of the utmost importance and should be thoroughly investigated and noted at this time. Any obvious easement or security issues should be noted and investigated also.

- Observe and investigate weight (load) considerations. Load restrictions, whether on the access road, elevator or floor, should be thoroughly investigated and noted at this time. Obtaining special permits if required to access a site may be time-consuming.

NOTE: Without proper investigation and planning, load restrictions can prevent a site from being used.

- Note potential environmental concerns such as wetlands, dump site, oil spills, garbage piles, nearby truck stops, and fueling stations.
- Note the type of property (existing facility, building top, private, state, or federal property).
- The construction location should be relatively clear of trees and brush. There should be an adequately sized layout/fabrication area adjacent to the construction area; lack of such area may hinder cost-effective construction.
- The construction location should be on level, firm land free of drainage and soil erosion problems.
- In locations where permafrost exists, the building must be isolated from the surrounding earth. Even the small temperature differential presented by an equipment shelter may be sufficient to melt the surface soil, leading to major structural and foundation damage. Workable solutions include building the structure on stilts or insulated pilings. Though it is also possible to construct on bedrock, special methods for anchoring and grounding must be used.
- If it is recommended or required that an existing tower or structure be used to support proposed additional antennas and transmission lines, then the original designer should perform a structural and foundation analysis.

NOTE: It may be impractical or impossible to add more antennas to an existing tower or structure due to the retrofitting required or the physical limitations of the tower, structure or foundations themselves.

- If it is recommended or required that an existing tower or structure be used to support proposed antennas and transmission lines, the site should be observed for potential electromagnetic energy (EME) issues. An interference analysis **shall** be performed to determine interference that may exist at the location.

Additionally, these tasks may be recommended to be performed based on the initial site walk:

- On existing facilities, perform a preliminary R56 compliance inspection to ensure proper planning and advisement to the customer (if required). Ensure proper testing and measurement of existing ground system integrity, if practical.
- Perform four-point soil resistivity testing if required. See “Soil Resistivity Measurements” on page B-1.
- Take subsurface soil core samples for soil resistivity if practical.

2.7 PERMITTING, ZONING, CODE AND REGULATORY CONSIDERATIONS

Obtaining permits and complying to local codes, ordinances and regulations can be complicated and time-consuming. It is highly recommended that all involved parties carefully plan and execute this portion of the project. To avoid unexpected problems, confer with all authorities having jurisdiction before beginning construction, and provide them with clear execution plans. To assist with permitting, zoning, code and regulatory considerations, it is recommended that the Motorola Site Design and Integration Team be consulted.

Some municipalities require that all communications installations which will share public safety facilities (police or fire stations, hospitals, etc.) must be constructed to standards under the State “Essential Services Act.” This requires that seismic upgrading and installation practices be met, and emergency power systems be upgraded to handle the new demand for the entire facility, sometimes at considerable additional costs. Even if the shared communications site lease does not specifically identify the need to comply with Essential Services Act standards, there may be “catch all” clauses which state that “all applicable local, state, and federal laws and requirements shall be met.”

2.7.1 AMERICANS WITH DISABILITIES ACT CONSIDERATIONS

NOTE: The following specifically applies to sites located within US jurisdiction. However, other jurisdictions may have similar or more stringent requirements. In all cases, the more stringent requirement takes precedence.

The Americans With Disabilities Act (ADA) is a US federal program signed into law as Public Law 101-336 July 26, 1990 104 Statute 327. Of greatest importance regarding a communications site is the following language contained in Title I which requires that:

“...business must provide reasonable accommodations to protect the rights of individuals with disabilities in all aspects of employment.”

At communications sites, this may result in changes in workstations and work areas to provide required accommodations. Some effects on a communication site regarding ADA compliance are:

- Providing extra-wide entry doors
- Providing a ramp for building access, a hand rail, and a turnaround area for wheelchairs within the building
- Providing convenient placement of telephones and light switches
- Providing dedicated paved handicap parking spaces

While some domestic municipalities are not yet requiring ADA compliance, many large cities are. Such regulations may significantly affect communications site development. The Uniform Building Code (UBC), Chapter 31 Accessibility, addresses these requirements in detail. UBC Chapter 31 Article 3104(3), Egress, in part, specifies a requirement for a 1.22 m (48 in.) width doorway. Article 3104(4), Article 3105 Facility Accessibility, requires that a telephone or other communications system **shall** be available.

2.7.2 FEDERAL CLEAN WATER ACT CONSIDERATIONS

The Federal Clean Water Act (FCWA) **shall** be considered during site development. FCWA programs administered by local governments sometimes vary with different requirements and enforcement for specific locations. The FCWA may require that common HVAC system condensate water be carried to a legal building drain system and may not be disposed of in the ground soil. This may result in requirements to include condensate pumps on HVAC systems and to plumb the HVAC condensate water to a proper sewer system.

2.8 FIRE SUPPRESSION

Fire is a hazard that must be taken into account when designing a communications room or structure. An appropriate means of preventing and controlling the spread of fire must be provided to help protect people sharing the structure or working with the equipment. Appropriate fire detection and suppression is typically required at communication sites where persons are manning the facilities. Where applicable, these facilities **shall** be designed in accordance with local jurisdictional codes.

2.9 ELECTRICAL SERVICE

The following list is provided to help organize, manage, and coordinate electrical service installation. Some items may not apply to all projects. Ensure that the electrical installation process is tracked, managed and documented by responsible parties.

- It is recommended that one person from the utility company be established as the point of contact. Ensure that the utility company's work order tracking methods and processes are understood. Typically a customer tracking number is assigned.
- Where practical, keep overhead lines and poles at least 61 m (200 ft.) from the site compound area during construction. This helps protect against accidental contact by construction or maintenance equipment and hazards associated with ice falling from the tower while under construction.
- To facilitate single-point grounding, request that electrical service enter the site building on the same wall as and near to the entry point for the antenna transmission lines.
- Proper separation between overhead electrical service conductors and antenna transmission lines **shall** be a minimum of 0.6 m (2 ft.) (NFPA 70-2005, Article 810.13). This may require coordination between the site development engineer and the shelter manufacturer to ensure consistency in layouts.
- Utility installations are jurisdictional. Ensure that it is clearly understood who the utility supplier will be. This is best achieved with a site meeting.
- Coordinate other utility installations such as closed-circuit television (CCTV) and telephone company.
- Supply the utility with an electrical utility information form.

NOTE: Additional site-specific load or use information, such as type of equipment, generator or uninterruptible power supply (UPS) information, may be required.

- Obtain an installation cost estimate from the utility company.

- It is imperative that the proper easement paperwork **shall** be obtained and provided to the utility.

NOTE: Governmental agencies transferring land or granting easements may take considerably more time than private landowners.

- A copy of the utility site installation sketch, staking sheet or overlay **shall** be obtained. It is imperative to check that the utility company interpreted the request for service correctly and that they have conformed to easement restrictions. It is easier to correct problems in the design phase than after service installation has started.
- Typically, final electrical service connection to the meter pedestal will not take place until the utility has been paid.
- The utility company usually requires a site address before they will connect power. Utility companies may or may not assign the address. It is more likely the local township will assign the address.
- A jurisdictional electrical inspection is usually required before the utility company connects power.
- The electric meter, but not the meter pedestal, is typically supplied by the utility. Verify who is responsible for providing the electric meter.
- Electrical service installations in very cold climates are typically much more expensive and likely to slow the installation schedule.

NOTE: When a soil boring test is performed, the local soil resistivity, soil pH and the type and concentration of dissolved salts should be established to aid in the design of the grounding electrode system. (TIA/EIA-222-F-R2003). See “Dissimilar Metals and Corrosion Control” on page 4-34.

2.10 FOUNDATION DESIGN AND INSTALLATION

2.10.1 FOUNDATION AND GEOTECHNICAL SERVICES

Foundation monitoring services are required when structural soils and foundation work is performed. They may also be required for certain other sub-surface and surface work. Monitoring services report whether the soils and concrete conform to design limits specified by either the tower and foundation designer or site engineering firm before, during or after installation. If the specified design limits are not met, the foundation monitoring service **shall** notify the contractor and Motorola to ensure that the noncompliance is corrected. This service is sometimes performed by the geotechnical firm.



WARNING

To prevent accidental damage to underground utilities, always have the local utility company or utility locator service locate the underground utilities before excavating or digging at a site.

NOTE: Firms offering this service may be able to provide a checklist to use as a guideline for the project.

2.10.2 CONCRETE FOUNDATION DESIGN AND INSTALLATION CONSIDERATIONS

This paragraph describes the design and construction considerations and requirements for communications site concrete foundations, including prefabricated communications shelter foundations and tower foundations.

NOTE: If concrete encased electrodes (Ufer grounds) are to be utilized, they must be addressed, engineered and installed before the concrete is poured. See “Concrete-Encased Electrodes” on page 4-20.

2.10.2.1 PLANNING

- Foundation design for prefabricated shelters and other equipment **shall** be based upon site soil conditions as noted in the geotechnical report. These foundation plans for buildings and ancillary equipment **shall** be designed by a licensed Professional Engineer and the design **shall** be included in the construction drawing package.
- A Professional Engineer or contracting firm **shall** determine whether the soil is adequate to properly support the concrete foundation or slab. The Professional Engineer or contracting firm **shall** determine the excavation depth and the required fill, if required.
- To ensure personnel safety, all excavations **shall** be conducted in accordance with Occupational Safety and Health Administration (OSHA) safety and excavation regulations, or other applicable Occupational Safety and Health standards and/or local safety regulations (whichever is most stringent).
- All foundation designs **shall** be approved by contracted Professional Engineer or contracting firm prior to commencement of work.
- A concrete foundation is typically used for building and shelter installations. If a foundation is used, the foundation **shall** be appropriate for the structure.
- All foundation construction **shall** be performed by a qualified contractor specializing in this work.
- If a site is to use concrete-encased grounding electrodes within the foundation or other concrete structures, appropriate measures **shall** be taken to accommodate the grounding system within a concrete structure before the concrete is poured. (See Chapter 4, “External Grounding (Earthing),” for additional information.)
- A foundation for a prefabricated shelter **shall** be built in accordance with the manufacturer's specifications and site specific soil conditions. The Architectural and Engineering firm providing the construction drawings will coordinate and include final foundation designs in the drawings.
- Foundation design **shall** consider any precipitation conditions unique to the location. These considerations include (but are not limited to) elevated (pier type) platforms used in low-lying areas prone to regular flooding, and elevated foundations used to prevent burial of site due to snowfall. Special foundation designs include:
 - Footings
 - Piers
 - Columns
 - Grade beams

2.10.2.2 PREPARATION

- All excavations on which concrete is to be placed **shall** be substantially horizontal on undisturbed and unfrozen soil and **shall** be free of loose material and excess ground water. Methods for removing excess ground water **shall** be provided if required.
- The foundation area **shall** be graded to provide water runoff and prevent water from standing. The final grade **shall** slope away in all directions from the foundation.

2.10.2.3 POURING

- Concrete forms of wood, metal centering, cores, molds, and so forth, **shall** be used as required for the proper execution of the plain and reinforced concrete work. Sufficient quantities **shall** be used to properly execute and expedite work without endangering the safety or strength of any part of the construction.
- All forming **shall** be true and rigid, thoroughly braced, and sufficiently strong to safely carry all dead and live loads to which it may be subjected. The elimination of forming by a monolithic pour against undisturbed soil **shall** be allowed **only** if approved by a soils engineer and/or a qualified Motorola representative.
- All steel reinforcement **shall** be furnished and installed in accordance with the approved foundation drawing. Unless otherwise specified or shown on plans, reinforcement **shall** consist of preformed bars of intermediate grade, manufactured from new billet stock. Metal reinforcement **shall** conform to the requirements of the latest version of *Specifications for Deformation of Preformed Steel Bars for Concrete Reinforcement*, ASTM A615-68, or applicable jurisdictional code, whichever is more stringent.
- Anchors, bolts, and miscellaneous iron work **shall** be set as shown in the drawings before pouring concrete. Embedded items **shall** be held rigidly in place during placing and curing of concrete. Placing rebar in position as the concrete is placed **shall not** be permitted.
- Concrete **shall** be vibrated and thoroughly consolidated around all embedded items.
- At least one week prior to all concrete pours, the proposed concrete mix design **shall** be submitted to Motorola or its contractor for verification of design specifications.
- When concrete is placed, certificates **shall** be furnished for each delivery vehicle or every 5.4 m³ (7 cu. Yds), showing the mix proportions, additives, compressive strength, and the brand name and type of cement.
- Concrete **shall** be so deposited that there will be no separation or segregation of aggregate. Maximum free drop **shall not** exceed 2.43 m (8 ft.).
- Concrete **shall not** be placed when the outdoor temperature is below 4.5° C (40 degrees F) nor when the concrete is likely to be subjected to freezing temperatures before final set, except when adequate provisions have been made for protection. When deposited in the forms, the concrete **shall** have a temperature of not less than 15.5° C (60° F) and not more than 32° C (90° F). A suitable means **shall** be provided to maintain the temperature above 10° C (50° F) for 7 days. The materials **shall** be heated before mixing to prevent concrete from freezing.

2.10.2.4 BACKFILLING

- After completion of the foundation and other construction below grade, and before backfilling, all excavations **shall** be clean of vegetation, trash, debris, and inorganic materials.

- A soils engineer **shall** determine if the onsite excavated materials are adequate or suitable for use as backfill material. If the material is not suitable, then engineered soils **shall** be determined by the soils engineer.
- Foundation backfill **shall** be placed in layers no more than 305 mm (12 in.) deep before compaction. The backfill requirements of each site differ based on conditions at the site.
- A foundation for a cabinet **shall** be level and sealed.

2.10.3 CONCRETE AND SOILS INSTALLATION MONITORING

Test requirements for different types of concrete foundations are provided in Table 2-1.

TABLE 2-1 FOUNDATION AND SOILS MONITORING REQUIREMENTS

Requirement	Type of Foundation			
	Drilled Piers (Caissons)	Deep Mat	Guy Tower Sites	Eqpt. Shelter Foundations
Confirm and obtain concrete mix design from foundation designer.	X	X	X	X
Perform penetrometer test at the base of the mat or tower excavation to verify soil bearing conditions. The number of test locations is dependent on soil conditions. The Geotechnical firm shall provide bearing values for specific locations. NOTE: Penetrometer tests are not required at the bottom of guy anchor thrust block excavations.		X minimum 3 to 5 locations	X minimum 2 to 3 locations	X minimum 2 to 4 locations
Collect bulk sample for Modified Proctor compaction testing. Expedite sample to lab to accommodate a 7-day concrete cure period (unless a high early type mix is used) then a shorter turnaround is required.		X	X	X
Identify specific caisson(s) being installed and include in daily field log and concrete report.	X			
Confirm and note caisson diameter and depth in concrete report.	X			
Confirm, note and ensure caisson bottom is clean and free of debris.	X			
For caissons, confirm and note placement of reinforcement cage and ensure it is centered in caisson pier. For other foundations, confirm and note placement of reinforcement steel with respect to foundation design.	X	X	X	X
Confirm and note that method of concrete placement is as specified by foundation designer(s).	X	X	X	X

TABLE 2-1 FOUNDATION AND SOILS MONITORING REQUIREMENTS (CONTINUED)

Requirement	Type of Foundation			
	Drilled Piers (Caissons)	Deep Mat	Guy Tower Sites	Eqpt. Shelter Foundations
Perform concrete field tests (slump, temperature and air content) and cast a minimum of one set of test cylinders (four cylinders per set) for every 19.1 m ³ (25 cu. yd.) of concrete placed. Perform new set of tests and cylinders once five yards beyond the 19.1 m ³ (25 cu. yd.) increment. Examples: 61 m ³ (80 cu. yd.) = four sets of test cylinders. 23 m ³ (30 cu. yd.) = two sets of cylinders).	X	X	X	X
Confirm and note that a working vibratory wand is used to consolidate the upper 3 m (10 ft.) of concrete placed in each caisson or the tower mat foundation.	X	X	X	X
Ensure that newly formed test cylinders are placed in an insulated cure box or other heated area to protect against freezing temperatures. Note that other methods of curing may be more acceptable or desired.	X	X	X	X
Test concrete cylinders in accordance with latest version of American Concrete Institute (or authority having jurisdiction) standards and note in concrete test log.	X	X	X	X
Note unusual developments such as rejected concrete, weather or construction delays, difficulty in setting anchor bolts, or casings stuck in place.	X	X	X	X
Perform, confirm and note density tests on each new lift of tower foundation backfill to verify it is compacted to 95% of the Modified Proctor maximum density value test (ASTM D1557). Note the type of compacting equipment used.	X	X	X	X
Specifically note the anchors or locations worked on and the order in which they were poured.			X	
Ensure backfill and undercut areas for non-structural applications (such as around pre-fabricated shelter foundations) are compacted to 90% of the maximum dry density value determined by the latest version of Standard Proctor test (ASTM D698).				X

2.11 SITE AND FACILITY ACCEPTANCE TESTING

When site development, including tower construction, antenna and transmission line installation, utility connection, building or shelter placement or construction, and roadway construction, is complete, all applicable areas of the site **shall** be inspected and tested, to ensure that all installations and alarms are functioning properly before the site is presented for customer acceptance. All aspects of the inspection and testing **shall** be documented. Items to inspect and test may include but are not limited to the following:

- Site AC power and alarms
- Transfer switch functionality and alarms
- HVAC equipment and alarms (including high and low temperature and high humidity)
- Generator functionality and alarms
- Fire or smoke detection devices
- UPS functionality and alarms
- Tower lighting functionality and alarms
- Dehydrator functionality and alarm
- Security measures such as door alarms and deadbolts
- Antenna and transmission line installations
- Concrete compressive strength requirements
- All aspects of the site, building and tower drawings are met or properly as-built
- General workmanship
- Site and building are clean and free of trash and debris
- Tower installation is in accordance with the latest version of ANSI/EIA/TIA-222 (or other applicable local Standards body design requirements)
- R56 audit

2.12 TOWER DESIGN AND CONSTRUCTION

When designing a tower site with a related equipment shelter, it is recommended that the tower be placed a minimum of 9.1 m (30 ft.) from the shelter when possible. This distance provides a balance between line loss in the antenna transmission line and the reduction in the amount of electromagnetic energy (EME) induced into the shelter in the event of a tower lightning strike. The separation will also help increase the ability of the tower grounding electrode system to dissipate the lightning energy before it reaches the shelter.

It is recommended that the distance between the tower and the shelter be no less than 3 m (10 ft.) to help prevent ice damage to the building, and EME effects.

NOTE: Increasing the distance between the tower and shelter from 3 m to 9.1 m (10 ft. to 30 ft.) reduces the amount of EME induced into the building by a factor of 9 (EME reduction factor = distance factor²). For example, increasing the distance by a factor of 3 (from 10 ft. to 30 ft.) results in an EME reduction factor of 3², or 9.

NOTE: Twist and sway of a tower affects the performance of microwave links. Therefore it is imperative that the proper loading information for each tower **shall** be supplied to the tower designer to help ensure that the tower meets ANSI/EIA/TIA-222 (or other applicable local Standards body) requirements.

All tower and tower loading design **shall** be performed by a registered professional structural engineer. If a structure other than a tower will be used to support a communication system antenna, the tower designer and/or a registered professional engineer specializing in tower structure design **shall** be contracted to analyze whether the structure can safely support the proposed load. Tower mapping may also be required.

Tower height is determined by a number of factors, including but not limited to the following:

- Required RF coverage
- Location
- Seismic risk probability
- Available area
- Existing structures in the vicinity
- Terrain
- Required antenna height
- Federal Aviation Authority (FAA) or jurisdictional approval
- Future tower capacity

Unless otherwise specified, all towers and foundations **shall** be designed to the latest version of ANSI/EIA-TIA 222 unless jurisdictional laws or codes mandate otherwise. The following tower design requirements apply:

- A minimum of one safety climb **shall** be engineered, supplied and installed on every tower.
- EME precautions **shall** be as described in Appendix A.
- Rest platforms **shall** be designed and installed per OSHA or other applicable Occupational Safety and Health standards, or as recommended by the tower manufacturer.

If additional antennas are to be added to an existing tower, or if a structure other than a tower will be used to support a communication system antenna, the original tower vendor and/or a registered professional structural engineer **shall** be contracted to analyze whether the tower or structure can safely support the additional load. Tower mapping may also be required.

Table 2-2 provides a brief comparison of the three most common tower types.

TABLE 2-2 COMPARISON OF TOWER TYPES

Factor	Self-Supporting	Guyed	Monopole
Cost	High More material required Foundation more expensive	Moderate More assembly cost required Land costs may be higher because more area is required for guy wires.	Moderate based on loading
Rigidity	High Self-supporting structure is typically more stable and better able to resist wind loading.	Moderate Provide resistance to wind sway, but are susceptible to torquing, especially when dish antennas are installed.	Low - wind resistance less than other types.
Land Required	Low	High - Location of guy anchors must be far from tower, requiring more property. May be unsuitable for populated areas due to land requirements	Low - Well-suited for urban areas with limited land availability.
Height	Moderate	High - Guyed towers may exceed 366 m (1200 ft.)	Low
Growth Potential	Moderate	Moderate	Low - Monopoles capable of supporting growth with room to rent space to other users may cost significantly more to build.

2.12.1 TOWER DESIGN DRAWINGS

Tower foundation drawings **shall** show the following information at minimum:

- Reference to the soil/geotechnical report, including file number, date and firm performing report, used in calculations and design.
- Required concrete compressive strength to be achieved at 28 days
- Grade and/or type of reinforcing bar
- Concrete coverage requirements
- Whether welding of rebar is permitted
- Whether cold joints are permitted; if so, the joining procedure **shall** be specified.
- Whether permanent steel casings are permitted for caisson installations
- Whether temporary steel casings are or may be required due to the expected soil conditions
- Any recommended concrete installation techniques such as a tremie
- References to all codes (and sections of codes) applicable for the design

- Plan, elevation and section views depicting a minimum of the following:
 - Length, depth, and width
 - Diameter
 - Finish grade with respect to top of foundation
 - Rebar size and placement
 - Anchor bolt size, type and placement
 - Above finish grade requirement for anchor heads (typically a minimum of 305 mm (12 in.))
- Estimated cubic yards of concrete per pier, caisson, mat, block or other type of foundation
- Backfill requirements such as but not limited to:
 - Material type
 - Thickness of lifts (typically lifts not more than 305 mm (12 in.) thick are acceptable).
 - Applicable compaction requirements; such 95% of modified proctor maximum dry density.
 - Applicable sub-grade compaction requirements; such as for a guy anchor. Upon completion of the excavation the designer may require certain compaction densities.
- Any other pertinent information that may be abstracted from the soils report, such as a high water table or large boulders.
- Any other pertinent construction or design information or considerations.

2.12.2 DESIGN CONSIDERATIONS TO HELP REDUCE EFFECTS OF LIGHTNING

Site design and physical layout can affect the susceptibility of a communications site to damage from lightning. The following topics are given as options to help reduce the harmful effects of lightning at a communications site.

2.12.2.1 POINT OF ENTRY FOR RF TRANSMISSION LINES

Reducing the height at which the RF transmission lines (coaxial cables) leave the tower and enter the building can reduce the susceptibility of a communications site to damage from lightning (Figure 2-1). The reduction in height reduces the voltage on the RF transmission lines before they enter the facility. A suggested best practice is for the coaxial cables to enter the facility at a maximum height of 610 mm (2 ft.) above the facility floor (United States National Weather Service Manual 30-4106-2004, “Lighting Protection, Grounding, Bonding, Shielding, and Surge Protection Requirements”).

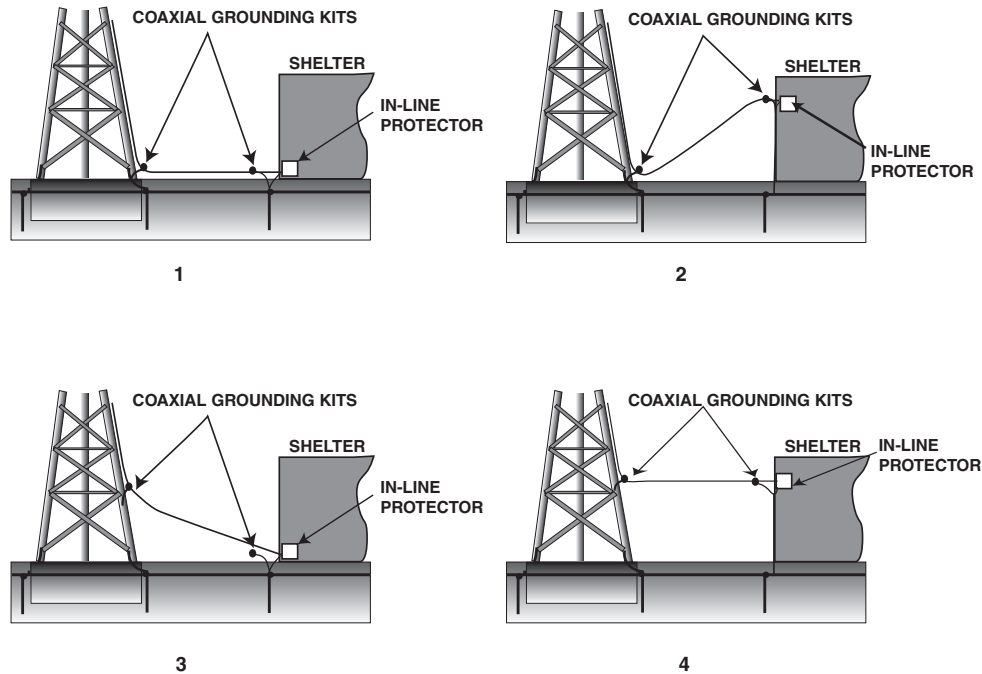

FIGURE 2-1 TRANSMISSION LINE ENTRY POINTS (IN ORDER OF PREFERENCE)

NOTE: The point of entry for RF transmission lines is especially important at facilities that are normally occupied, such as dispatch centers, and at facilities that are located on above-ground platforms (usually for the purpose of flood control). See Figure 3-6 on page 3-9 for an example of a shelter located on an above-ground platform.

2.12.2.2 DISTANCE BETWEEN TOWER AND BUILDING

Increasing the distance between the tower and building may reduce the susceptibility of a communications site to damage from lightning. Increasing the distance between the tower and building has the following benefits:

- It decreases the magnetic field associated with lightning that is coupled into the building. The amount of magnetic field coupled into the building decreases by the square of the distance. For example, the magnetic field coupled into a building would decrease by a factor of nine (9) if the distance between the tower and building is increased by a factor of three (3).
- It reduces the amount of energy that reaches the building via the RF transmission lines. This is because of the increase in inductance of the longer transmission lines.
- It reduces the amount of lightning energy that is propagated through the earth from the tower grounding (earthing) electrode system to the building grounding electrode system.
- Nine metres (30 feet) is considered a good compromise between protection level benefits and the length added to RF transmission line.

2.12.2.3 METALLIC TELECOMMUNICATIONS/DATA LINES

Whenever practical, metallic telecommunications/data lines should be eliminated from the facility. Metallic telecommunications/data lines provide a conductive path into the facility for lightning energy. Elimination of metallic telecommunications/data lines through the use of fiber optic cable (or other isolation device) provides isolation from lightning-induced ground potential rise (GPR) and lightning energy.

2.12.2.4 ISOLATION OF BUILDING AND TOWER FROM ICE BRIDGE/CABLE BRIDGE

NOTE: Applies to tower and/or building-supported ice bridges and cable bridges.

In order to reduce the amount of lightning energy diverted toward the equipment building/shelter, and to provide seismic isolation between the building and tower, it is recommended that the cable bridge/ice bridge be secured to the tower using a non-conductive slip-joint type device. When a slip-joint type device is used, grounding of the cable bridge/ice bridge **shall** be completed as described in “Cable Bridge/Ice Bridge Grounding (Earthing)” on page 4-71.

2.12.2.5 USE OF AIR TERMINALS ON TOWERS

The use of air terminals (lightning rods) on a tower may be appropriate in some circumstances to protect antennas from a direct lightning strike. If the tower is over 45.7 m (150 ft.) tall, side-mounted antennas are vulnerable to direct lightning strikes. Side-mounted antennas installed at a height greater than 45.7 m (150 ft.) may be protected through the use of horizontal lightning rods. The horizontal lightning rods are attached to the tower, just above and below the antenna.

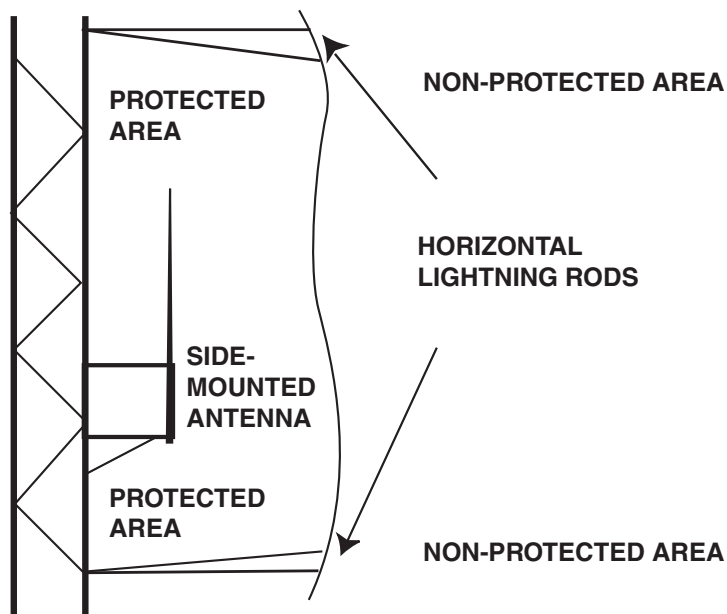

FIGURE 2-2 USING HORIZONTAL LIGHTNING RODS TO PROTECT SIDE-MOUNTED ANTENNA

2.12.3 TOWER SAFETY

Always observe the following safety guidelines when working with towers.

- Towers **shall** be erected and installed by bonded contractors specializing in such work.
- Any area involving tower construction **shall** be tied off to restrict entrance by unauthorized personnel.
- Fall protection measures **shall** be observed and implemented at any and all towers and structures, regardless of ownership, where climbing is required.
- Any and all applicable regulations regarding tower climbing **shall** be observed and implemented. The most stringent regulations **shall** supersede other regulations.
- Subcontractors **shall** be required to submit their written comprehensive Safety Program to Program Management and obtain approval prior to commencing any work.
- All tower climbing **shall** be in accordance with the Motorola Contractor Fall Protection Program.
- Towers **shall not** be overloaded.
- OSHA or other applicable Occupational Safety and Health standards regulations **shall** be observed in all phases of tower construction and maintenance.

2.12.4 REGULATIONS AFFECTING TOWERS

- In the United States, the Federal Aviation Administration (FAA) regulates and approves towers, including but not limited to tower height, location, marking, and lighting. Each state or jurisdiction may have additional regulating agencies which may designate specific marking or lighting requirements in addition to FAA requirements. It is highly recommended that the appropriate authorities having jurisdiction be identified and consulted before final tower design and construction begins.
- CFR 47, Part 17 – “Construction, Marking and Lighting of Antenna Structures” **shall** be followed to determine required paint markings and lighting for towers. Equivalent local standards **shall** be followed for nondomestic installations.
- A preconstruction notice **shall** be submitted to the FAA or local authority having jurisdiction at least 30 days before the date the proposed construction or alteration is scheduled to begin, on or before the date a construction permit application is filed with the Federal Communications Commission (FCC). Ensure that the FAA acknowledges receipt of the notice before beginning tower construction. Other notices may be required by the FAA on a case by case basis.
- All FAA, FCC, and jurisdictional rules and regulations **shall** be strictly followed throughout tower design and construction, and following tower completion. It is highly recommended that the appropriate authorities having jurisdiction be consulted before starting tower design and construction.
- Unless otherwise specified, tower foundation and anchor design **shall** be in accordance with the latest revision of ANSI/EIA/TIA-222 (or applicable local Standards body design requirements) or local jurisdictional code, whichever is more stringent.

2.12.5 SECURING THE TOWER

After construction, unauthorized entry to a tower **shall** be controlled as follows:

- Install a fence around the tower. The fence should be at least 1.8 m (6 ft.) high with barbed wire at the top.
- The guy piers of guyed towers should also be fenced with a gate and lock to help prevent accidental or malicious damage to the guy wires. A damaged or weakened guy wire could cause the tower to fall.
- If the tower has climbing pegs, the pegs should be removed from the bottom 6.1 m (20 ft.) of the tower to deter unauthorized climbing.
- If the tower has a climbing ladder or elevator, it should be appropriately secured.
- Appropriate signage notifying restricted access to the tower area and identification of tower **shall** be affixed to the fence in a conspicuous location.

2.12.6 ANTENNA AND DISH ANTENNA LOADING

Antenna loading requirements are one of the most critical aspects of tower design. Loading requirements include but are not limited to the following:

- RF antenna quantity, size, type, manufacturer, frequency, and elevation
- If required, future RF antenna loading requirements
- Microwave dish antenna quantity, size, manufacturer, frequency, azimuth, elevation, and radome
- If required, future microwave dish antenna loading requirements
- Transmission cable diameter and type
- Sidearm length and location
- Lighting requirements
- Additional ice or wind loading requirements applicable to the selected site
- Safety apparatus such as climbing ladders and rest platforms
- Miscellaneous optional equipment, such as ice shields

See Figure 2-3 for an example of a tower loading report.



Site Designator **7XXX** **Tower Loading Information**
 MSP No **7XXX**
 City **NewTown** Phase **3** Tower Type: **Self Support** *21-Dec-99*
 County **Charles** District **7** Tower Height: **475**
Tower Reference Azimuth: **0**
Ant. Engineering File Number:

Microwave Antenna System Information

Path No	Path Destination	Path Density	Radio Capacity	Azimuth	Path Distance	Antenna Height (CL)	Dish Size	Space Diversity	Diversity Ant. Ht (CL)	Div Dish Size	ERIP (dBi)	Polarization
91	7203b	high	28	43	14.8	135	6	<input checked="" type="checkbox"/>	95	6	66.8	Vertical
88	7302p4	medium	12	121.4	10.6	142	6	<input checked="" type="checkbox"/>	102	6	66.8	Vertical
89	7001b	high	28	160.605	11	160	6.1	<input checked="" type="checkbox"/>	99	6	64.8	Vertical
90	7904p1	High	28	237.145	15.8	125	8	<input checked="" type="checkbox"/>	80	6	69.3	Vertical
101	7804c	high	28	333.9	11.4	106	6	<input checked="" type="checkbox"/>	71	6	66.8	Vertical



Site Designator **7XXX** **Tower Loading Information**
 MSP No **7XXX**
 City **NewTown** Phase **3** Tower Type: **Self Support** *21-Dec-99*
 County **Charles** District **7** Tower Height: **475**
Tower Reference Azimuth: **0**
Ant. Engineering File Number:

Microwave Antenna System Information

Path No	Path Destination	Path Density	Radio Capacity	Azimuth	Path Distance	Antenna Height (CL)	Dish Size	Space Diversity	Diversity Ant. Ht (CL)	Div Dish Size	ERIP (dBi)	Polarization
---------	------------------	--------------	----------------	---------	---------------	---------------------	-----------	-----------------	------------------------	---------------	------------	--------------

800 MHz Antenna Information

One 800 MHz Rx Ant. Ht: **445**
 Number of 800 MHz Tx Ants: **2**
 Mounted at a Height of: **475**
 Model Number of Antennas: **PD100175a**
 NOTES:
 All Line for the 800 MHz Antenna Systems will be 1 5/8" Heliax
 1 5/8" Snap in hanger required for the site. **61**

Relocated Existing Antenna Systems Loading Requirements

Model Number of Antennas: **DB212**
 Mounted at a Height of: **200**
 Quantity of Antennas: **3**
 NOTE:
 All Line for the non 800 MHz Antenna Systems will be 7/8" Heliax
 If tower is less than 250' mount relocated existing antennas at highest available location.

Tower Marking and Lighting Requirements

- Marked (Painted):
- Medium Intensity White:
- Dual Medium Intensity (White and Red):
- High Intensity White:
- Dual High Intensity (White and Red):
- Conventional Red Lighting:
- Requires No Lighting:

- Notes:
- Compliance with future loading requirements mandates doubling all RF antennas listed above when calculating tower loading.
 - All Microwave Antenna Systems use EWP-63 Elliptical Waveguide.
 - All Microwave Antennas are Solid Dish Antennas with a Solid Molded Radome.
 - EWP63 hangers required at the site. **49** Packs of 10

FIGURE 2-3 EXAMPLE OF A TYPICAL TOWER LOADING REPORT

2.12.7 TOWER CONSTRUCTION

Tower construction **shall** be performed in accordance with the current edition of ANSI/EIA/TIA-222 (or other applicable local Standards body design requirements) or more stringent standard per jurisdiction. Tower construction general requirements are summarized in the following list:

- All personnel climbing a tower **shall** be tied off at all times.
- An RF engineer **shall** perform an RF site compatibility study to determine if any interference might occur with existing frequencies currently in use at the site.
- Antenna mounts **shall** be specified and installed as recommended by the manufacturer. Mounting devices **shall** be made of corrosion-resistant material.
- Qualified personnel certified for the correct installation and safety procedures associated with this type of work **shall** perform the installation.
- The highest point of the antenna and/or lightning dissipater **shall not** exceed the licensed height.

2.12.8 TOWER TRANSMISSION CABLES

Transmission line installation requirements are summarized in the following list:

- Tower lighting cables **shall not** be bundled along with transmission lines or other conductors anywhere within cable ladders, or the building interior.
- Each transmission line run **shall** have entry port boots (inside and/or outside), lightning protectors and associated mounting brackets, and any additional jumpering required by the site specific RF configuration. Some manufacturers provide transmission line kits, which include the main line connectors, top and bottom jumpers, line grounding kits (typically three per line), hoist grips, and weatherproofing materials.
- If the installation requires transmission lines that use air or nitrogen as the dielectric material between the conductors, a dehydration system **shall** be installed to maintain optimum humidity of the dielectric.
- Strain relief devices **shall** be used a minimum of every 60.8 m (200 ft.) during transmission line installation and **shall** remain in place to support the cable after installation. A support cable should be used between the grips to prevent damage to the transmission line caused by lifting from only one point.
- Coaxial cable transmission lines **shall** be bonded and grounded in accordance with Chapter 4, “External Grounding (Earthing).”
- To minimize the formation of condensation and ice on transmission lines, a drip loop should be created at the point where the direction of the transmission lines changes from vertical to horizontal. (Figure 2-4). To lessen the likelihood of moisture on the cables getting into the shelter, the cables should be installed with a slight upward incline as they approach the shelter.

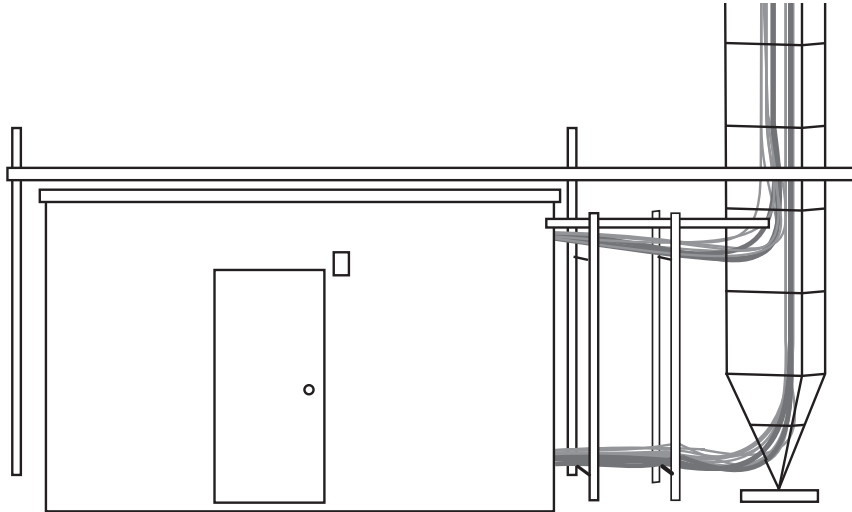

FIGURE 2-4 EXAMPLE OF ANTENNA TRANSMISSION LINE DRIP LOOP

- Transmission lines **shall not** be installed in a way that will impede climbing or safety devices.
- Transmission lines **shall not** be mounted to climbing ladder rungs or climbing pegs.
- Transmission line installation should be planned with consideration for future expansion.
- Excess transmission line **shall not** be stored (coiled or looped) on the tower.
- All transmission line connectors, splices, terminations, and jumpers **shall** be weatherproofed.
- Transmission line **shall** be anchored to the tower using hardware recommended by the transmission line manufacturer for that type of tower. Spacing of anchoring hardware is also determined by the line manufacturer and is dependent on the type and size of the line. Hangers and/or angle adapters are typically provided for every 914 mm (3 ft.) of line, including any ice bridge paths. All clamps and hardware **shall** be corrosion-resistant.
- Transmission lines **shall** be identified in a permanent manner using metal tags, or equivalent method located at the antenna, at the bottom of the tower, at the shelter cable entrance and inside the shelter or building.

2.12.8.1 ICE BRIDGE AND CABLE SUPPORT REQUIREMENTS

The requirements below apply to installations using ice bridges and/or cable support systems between the shelter and the tower. These requirements help minimize tower or shelter damage during an earthquake. General requirements are as follows:

- A self-supporting bridge and cable support system **shall not** be mechanically fastened to both the tower and the building, unless a nonconductive slip joint is used at one of the locations. The recommended separation between tower and ice bridge, or building and ice bridge, is 152 mm (6 in).
- An ice bridge and each support leg **shall** be bonded to the grounding electrode system in accordance with “Cable Bridge/Ice Bridge Grounding (Earthing)” on page 4-71.
- Ice bridges and cable support systems should be adequately supported and constructed from galvanized steel.
- A non-self-supporting ice bridge **shall** be connected with a nonconductive slip joint.

2.13 SITE DRAWINGS OF RECORD

All drawings developed in the process of site design **shall** be accurately maintained so that they reflect not only the intended design of the site, but also the way the site was actually built (as-built drawings). Drawings should be marked up to indicate modifications made at the site during construction. A map of the tower installation should also be maintained. Copies of all drawings and other pertinent information to support as-built site design and construction should be provided to the customer.

It is recommended that the responsible party for future installations or upgrades to the site maintain and update the drawings to accurately show all subsequent modifications to the site.

THIS PAGE INTENTIONALLY LEFT BLANK.

COMMUNICATION SITE BUILDING DESIGN AND INSTALLATION

This chapter provides requirements and recommendations for designing communications site buildings, including equipment shelters and outdoor cabinets. The following topics are discussed:

- “Site Categories” on page 3-1
- “Definitions of Communications Equipment Sites” on page 3-2
- “Building/shelter Design and Location Considerations” on page 3-5
- “Foundation Considerations” on page 3-8
- “Floor Loading” on page 3-9
- “Ceilings and Floors” on page 3-10
- “Weatherproofing/Sealing” on page 3-11
- “Heating, Ventilation, and Air Conditioning” on page 3-13
- “Special Considerations for Telephone Central Offices and Switch Rooms” on page 3-17
- “Lightning Damage Prevention” on page 3-17
- “Power Source Protection” on page 3-17
- “Central Office Layout” on page 3-17
- “Cable Trays” on page 3-18
- “Lighting” on page 3-22
- “Fire Protection/Safety” on page 3-23
- “Safety Equipment” on page 3-29
- “On Site Communications” on page 3-30
- “Signage” on page 3-31

3.1 SITE CATEGORIES

The list below describes typical configurations that could comprise a communications equipment site. See Chapter 4, “External Grounding (Earthing),” for Type A and Type B for definitions and site grounding requirements.

- Modules within a single rack:

Several frames of radio and support equipment within a general-purpose room, containing other telecom or broadcast equipment.

- Dedicated radio room within a new or existing building:
 - Self-contained outdoor cabinets (land or rooftop), or semi/fully underground vaults. These are often used where zoning or site availability are issues, sometimes in conjunction with camouflaged towers or antennas.
- Pre-fabricated equipment shelter of concrete/fiberglass construction:
 - The shelter may be installed at an existing tower site, a new tower site (green site) or on the roof of an existing building.
- A “shipping container” that has been outfitted as a self-contained radio site must meet strict dimensional requirements, including protrusions such as HVAC, RF entry assemblies, or AC entrances, and must conform to applicable shipping requirements.
- Renovation where an existing building or room is modified or retrofitted to accommodate a new communications system.
- A new “green site” on undeveloped land.

3.2 DEFINITIONS OF COMMUNICATIONS EQUIPMENT SITES

This manual defines and distinguishes various site types as described in Table 3-1.

TABLE 3-1 STANDARD DEFINITIONS OF COMMUNICATIONS EQUIPMENT SITES

Site Type	Description	Notes
Building	A permanent structure built on a foundation, containing communications equipment and related ancillary support systems, and which may contain other unrelated equipment and/or facilities. A building shall be suitable for human occupancy during equipment installation, maintenance, and use. A building typically does not have equipment or supporting systems (cable trays, antenna ports, etc.) installed before general installation.	Consists of dedicated site structures as well as interior installations such as shared commercial space in existing buildings, dispatch centers, central office installations, and other sites occupied, on a regular basis, by operations-related and possibly other personnel. Example: A dedicated dispatch center and communication equipment site within a dedicated, permanently occupied facility.

TABLE 3-1 STANDARD DEFINITIONS OF COMMUNICATIONS EQUIPMENT SITES (CONTINUED)

Site Type	Description	Notes
Shelter	<p>A permanent structure built on a foundation that contains communications equipment and related ancillary support systems. A shelter shall be suitable for temporary or permanent human occupancy during equipment installation, maintenance, and use.</p> <p>Example: (See Figure 3-1.) A prefabricated building, usually located with a tower or rooftop antenna system, which houses equipment related only to over-the-air communications. The shelter supports personnel only on a limited basis for installation and maintenance functions; a dispatch center would be located elsewhere in this case.</p>	<p>Consists of smaller buildings or prefabricated shelters containing only equipment directly related to the function of the site. A shelter is intended for human occupancy only during equipment installation and maintenance.</p> <p>The Motorola Standard Building (MSB) is a predesigned all-inclusive self-contained equipment shelter.</p>  <p>FIGURE 3-1 TYPICAL PRE-FABRICATED EQUIPMENT SHELTER</p>
Cabinet/ Enclosure	<p>An enclosure that houses communications equipment and ancillary systems only, designed such that equipment contained within can be accessed without the need for personnel to enter the cabinet. An enclosure is typically pre-wired and its equipment is pre-installed.</p> <p>Example: (See Figure 3-2 and Figure 3-4.) An unmanned, weather-tight enclosure.</p>	<p>A cabinet/enclosure can be installed indoors or outdoors, placed on a small foundation, or wall/pole mounted.</p> <p>A cabinet installed indoors uses the existing building environment (heat and air conditioning) to maintain temperature requirements. An outdoor cabinet contains its own environmental controls.</p>  <p>FIGURE 3-2 METAL SHIPPING CONTAINER ENCLOSURE</p>

TABLE 3-1 STANDARD DEFINITIONS OF COMMUNICATIONS EQUIPMENT SITES (CONTINUED)

Site Type	Description	Notes
Vault	<p>An enclosure that houses communications equipment and ancillary systems only and is fully or partially buried in soil. The vault supports personnel only on a limited basis for installation and maintenance functions.</p> <p>Example: Similar to a cabinet/enclosure, except the enclosure is buried below ground level.</p>	<p>Pre-fab shelters, cabinets, and vaults may have equipment fully or partially installed prior to building shipment, requiring additional building specifications to allow lifting with equipment installed. Weight and size must be considered if the site has limited access. For shipping, these structures must meet strict dimensional requirements, including protrusions such as HVAC, RF entry assemblies, or AC entrances. In the US, state certification may be required if pre-fab buildings are manufactured in a different state than deployed. (Similar requirements regarding out-of-state or province manufacture may also apply in non-domestic situations.)</p>
Rack	<p>A standard equipment rack used for supporting communications equipment to be installed in an existing Building or Shelter.</p> <p>Example: (See Figure 3-3) A radio rack installed in an existing building or shelter to provide an added function to the existing site. A standard rack is intended for indoor installation only in buildings or shelters.</p>	 <p>FIGURE 3-3 TYPICAL EQUIPMENT RACK</p>

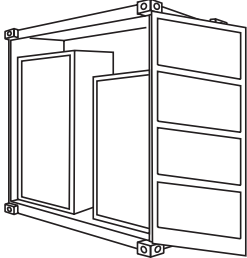

FIGURE 3-4 TYPICAL OUTDOOR ENCLOSURE CABINET ON RAISED PLATFORM

3.3 BUILDING/SHELTER DESIGN AND LOCATION CONSIDERATIONS

Pre-fab buildings shelters, cabinets, and vaults may have equipment fully or partially installed prior to building shipment, requiring additional building specifications to allow lifting with equipment installed. Weight and size become a consideration if the site has limited access. For shipping, these structures must meet strict dimensional requirements, including protrusions such as HVAC, RF entry assemblies, or AC entrances. In the United States, state certification may be required if pre-fab buildings are manufactured in a different state than deployed. (Similar requirements regarding out-of-state or province manufacture may also apply in non-domestic situations.)

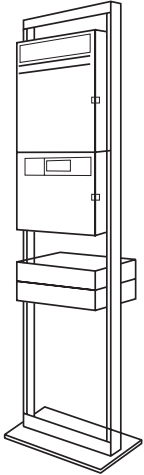
The following are general considerations regarding sites utilizing a new building or shelter capable of human occupancy.

- Consideration **shall** be given to the amount and type of equipment to be housed, along with adequate space for movement and expansion within the structure. The extent of equipment housed will typically determine the suitability of prefabricated structures (if desired). See Chapter 6, “Power Sources,” for electrical power sources and Chapter 9, “Equipment Installation,” for equipment installation.
- Equipment configuration typically dictates the structure design. The desired size and composition of a prefabricated shelter **shall** be considered along with weight in transporting the shelter to the site.
- All sites utilizing a constructed structure or a prefabricated structure with manned access **shall** utilize exterior lighting to some extent. See “Lighting” on page 3-22 for specific details on requirements for various categories of structures.

- Always consider not only the initial equipment loading of the site, but also future growth, which may double or triple the initial equipment and/or necessitate additional space at a site. This design should always include the shelter size, air conditioning, UPS, generator and electrical system.
- A “single point” grounding concept is required. This includes a single ground point located at all of the outside shelter or equipment room penetrations (RF, AC power and generator, GPS, tower light controllers, equipment and phone lines). This design will affect the overall equipment layout. DC power systems should also logically be located close to this ground point. Though this uses up some wall and floor space, it permits the systematic growth of communications equipment outward.

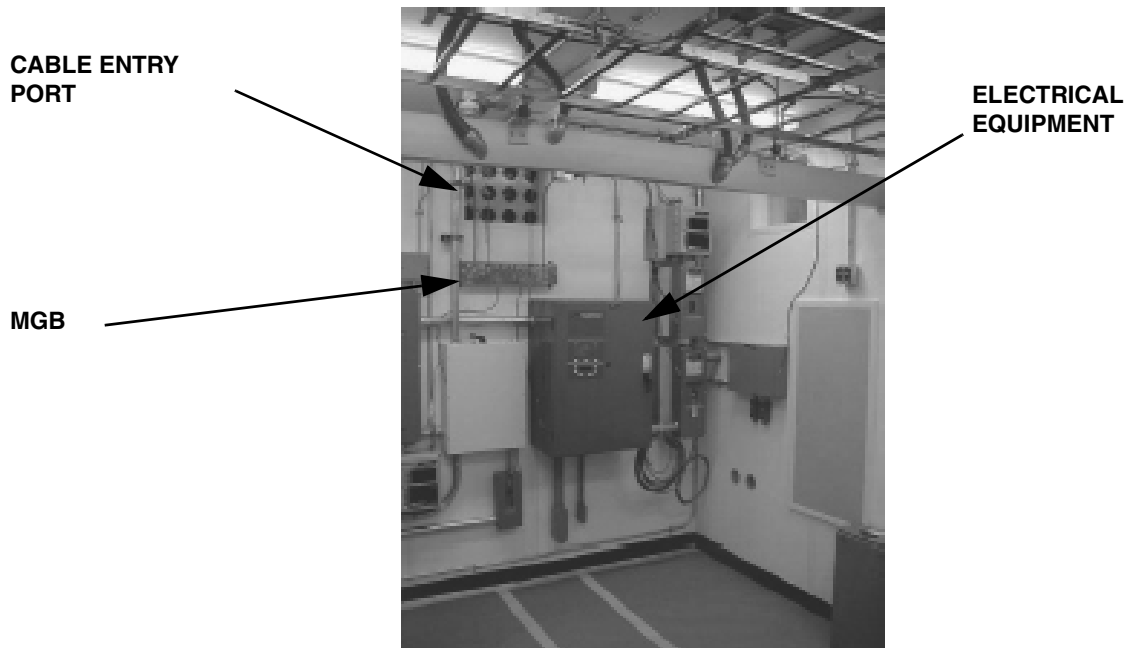

FIGURE 3-5 SINGLE-POINT GROUNDING AT ENTRY TO BUILDING

- Though not usually required for building foundations, some sites with unique soil conditions may require soil boring tests. Soil borings reveal the soil strength and water content, which are used to design a suitable foundation.
- In earthquake-prone areas (Moment Magnitude rating 3 or greater), foundation design and equipment anchoring **shall** address seismic requirements.
- Where high soil resistivity results in a poor grounding electrode system, see Chapter 4, “External Grounding (Earthing),” for information on using concrete encased electrodes (Ufer ground) as a supplemental ground.
- All buildings and shelters **shall** be designed or use features that prevent entry of animals and insects into the structure. Design should help discourage nesting of birds and small animals on exterior features of structure.
- Buildings may require compliance with human accessibility standards, such as Americans with Disabilities Act (or equivalent where required). These requirements must be considered during layout and procurement of facility.

- Buildings and shelters should utilize a locked chain-link fence where appropriate and appropriate deadbolt locks on standardized steel doors. Shelters and outdoor equipment cabinets **shall** be of the type designed for electronic equipment housing and accordingly fitted with locking doors.
- Buildings and shelters should utilize an alarm system capable of notifying a remote location of tampering, cable breakage, power outage, or system failure.
- When installing equipment racks, it is recommended that those located furthest from the access door be installed in the shelter first, so other equipment can be installed without having to fit it behind existing equipment.
- The current and reasonable future needs of the customer should be understood when considering available equipment enclosures. The customer should be made fully aware of the types of enclosures available.
- Shipping a prefabricated structure to a site may require special road use permits and/or special transportation methods (crane, double-length truck, helicopter, and so forth). Be sure the customer understands the shipping costs associated with a given building or shelter.

3.3.1 LOCATION CONSIDERATIONS

Sites should be selected for construction with the following consideration; cost, limited site preparation, environmental impact, public acceptance, accessibility, and future growth.

Roof-top shelters require a structural engineering analysis for both initial and final configurations. Verify that all portions of the access route to the installation site, including stairways and elevators, are also capable of supporting the weight of the enclosure. If the equipment must be lifted to the rooftop by a helicopter it will add significant cost to the project.

3.3.2 EQUIPMENT SHELTER OFF-LOADING



WARNING

To help prevent injury and/or damage to equipment, all appropriate safety precautions shall be taken during shelter off-loading.

The equipment shelter type determines the method and means by which it is off-loaded from the truck that transported it to the site. Typically, shelters require extensive rigging and a large hydraulic crane to off-load and set.

NOTE: It is required that all cranes be inspected and tested by crane operator personnel prior to any lift for Motorola related projects. Construction supervisory personnel **shall** insist that the crane operator demonstrate that the crane has been inspected. Any questions regarding this requirement **shall** be directed to the Motorola Project Manager.

3.3.3 SEISMIC CONSIDERATIONS

In seismically active regions appropriate seismic design factors must be incorporated into the building or shelter construction or layout. Site locations having a moment magnitude (MM) rating of 3.0 or greater require seismic design standards described below and in respective sections of this manual.

US seismic activity maps are available in Uniform Building Code, P. 194, Dia. 23-2, US Seismic Map. US maps and graphs are available on the following US Geological Survey (USGS) web pages:

<http://neic.usgs.gov/neis/states/>

Also, seismic information can be found using the search function provided on the USGS home page at:

<http://www.usgs.gov>

General seismic information can be found at:

<http://geohazards.cr.usgs.gov>

Also see IBC 2000, chapter 16 for seismic acceleration.

In general, observe the following considerations when designing to accommodate seismic risks of MM 3.0 or greater:

- A qualified architect **shall** be contracted to determine seismic structural needs for a specific location. Proper seismic design of a site helps ensure safety of personnel at the site should an earthquake occur.
- Shelters **shall** incorporate a steel door frame and a steel door for security and seismic integrity. In an earthquake a structure may deform, preventing doors from being opened from the inside. As most communication sites do not have windows, this becomes a serious issue for trapped occupants. Some concrete prefabricated shelter manufacturers also cross-brace the door frame area to prevent deformation during an earthquake.
- Only specifically designed seismic support hardware **shall** be used for seismic bracing.
- Seismic battery racks, seismic bracing and support, and seismic facility and antenna structure construction practices **shall** be employed in seismically active locations. Storage cabinets **shall** be closable and secured to walls.

3.4 FOUNDATION CONSIDERATIONS

- All foundation designs **shall** comply with the guidelines set forth in “Foundation Design and Installation” on page 2-11.
- The foundation **shall** be appropriate for the structure.
- If a site is to use concrete-encased grounding electrodes within the foundation or other concrete structures, appropriate measures **shall** be taken to accommodate the grounding system within a concrete structure before the concrete is poured. See “Concrete-Encased Electrodes” on page 4-20.
- A foundation for a prefabricated shelter **shall** be in accordance with manufacturer's specifications. Prefabricated building manufacturers usually provide typical foundation specifications for their particular model of building.
- A foundation for a cabinet **shall** be level and sealed.

- Design of foundation **shall** consider any special precipitation conditions unique to the installation locality. These considerations include, but are not limited to, elevated (pier type) platforms used in low-lying areas prone to regular flooding and elevated foundations to prevent burial of site due to snowfall. Special foundation designs include:
 - Footings
 - Piers
 - Columns

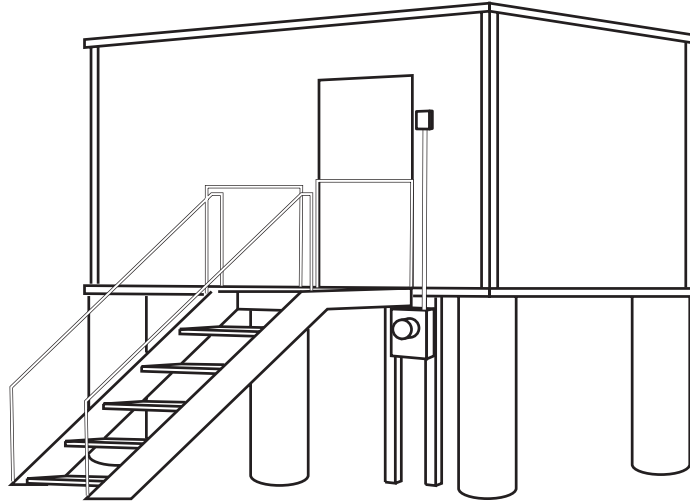

FIGURE 3-6 TYPICAL SHELTER MOUNTED ON ELEVATED PIERS

3.5 FLOOR LOADING

When determining equipment placement in an existing structure or when developing building specifications for an equipment shelter, attention **shall** be given to the Structural Live Load capacity of the building. Standard commercial construction specifications will, in most cases, provide substantial floor loading capacity. However, stacking and/or back-to-back placement of some equipment may exceed structural load limits. The weight and footprint dimensions of each piece of equipment to be installed **shall** be used to calculate floor loading.

The minimum floor loading standard for current Motorola manufactured equipment is 635 kPa (300 lb/ft² (PSF)). Calculations of the weight of the proposed equipment in PSF **shall** be compared to the rated load carrying capacity of the structure.

Battery configurations can sometimes be specified with feet, rails, or specialized load spreading devices that can facilitate deployments in high-rise structures. It is often necessary to specify a battery's location within a pre-fabricated shelter, such that if the building is staged (fully equipped and optimized) before shipment, the building has enough structural strength to be lifted and transported fully loaded.

Battery configurations with weight exceeding 300 lb/ft² **shall** utilize a specialized load spreading device for the battery rack. Remember to plan for expansion when calculating floor loading.

The civil engineering firm, contractor, or architect responsible for designing and/or constructing the site will need data relating to expected floor loading. Typically, the following initial information is required:

- Total weight of the equipment to be installed, determined by adding the individual weights of all electronic equipment, racks, and other ancillary support equipment to be installed.
- A diagram showing the amount, weight, and proposed location of the equipment planned for installation.

The engineering firm will determine whether the existing floor is adequate, and if not, how the floor can be reinforced to safely support the weight.

The distributed weight **shall not** exceed the rating of the existing floor and **shall** conform to jurisdictional building codes. If an engineering firm is designing the structure, ask their assistance in calculating floor loading.

Some of the practices used to distribute a Structural Live Load can prove to be counterproductive in an earthquake. For example, steel I-beams are sometimes used to support a modular shelter between parapet walls of a high rise building, where the roof itself could not handle the weight without costly retrofit. In an earthquake, the I-beams will flex to their limits with the moment of the shelter movement. This can all but destroy a shelter and its contents. Rooftop isolators attached between the roof surface and the I-beam supports can dampen the movement of the shelter, absorbing the energy of an earthquake.

3.6 CEILINGS AND FLOORS

For Tenant Improvements in existing high-rise buildings, it is critical that the contractor determine if post-tensioning is employed in floor, roof, or wall construction. If so, industrial X-ray mapping is required to avoid structural damage caused by accidental penetration of a tensioning cable.

3.6.1 CEILINGS

The following general considerations must be observed when designing a site building, selecting a prefabricated shelter, or installing equipment in an existing structure or room:

- Ceiling height **shall** conform to applicable jurisdictional building codes.
- Minimum acceptable ceiling height for communications sites utilizing 2.2 m racks (standard 7.5 ft. rack) are recommended to be 2.75 m (9 ft.).
- When adding equipment to existing sites, ensure that the ceiling is high enough to accommodate the planned additional equipment, including stacked cabinets.
- Determine the height of the tallest rack that could be deployed at a site, and then provide additional height to accommodate cabling, working room, and ventilation.
- Consider the size of the cable that might be attached to the top of the rack and that cable's bending radius. Typically the cable tray will be a minimum of 152.4 mm (6 in.) above the tallest rack or cabinet.
- The cable tray should be installed to provide at least 305 mm (12 in.) clearance between the cable tray and the ceiling (ANSI/TIA/EIA 569-B).
- In a site where the existing ceiling is too low to accommodate the specified clearances, the location of the cable tray may be moved to above the aisle behind the equipment row. Good site engineering practices must be considered, including accommodation of any electrical and working spaces.

3.6.2 FLOORS

Observe the following general considerations when designing a site building or selecting a prefabricated shelter:

- Floor construction **shall** conform to applicable jurisdictional building codes.
- Except for access flooring, floors should be constructed of concrete or wood. Normally if the building shelter floor is at ground level, the floor is concrete. If the building shelter is elevated from ground level, the floor is normally constructed of heavy duty floor joist and plywood or a Viroc composition.
- Concrete used as communications site flooring **shall** be properly mixed to ensure adequate tensile strength when under load.
- Concrete **shall** be poured and reinforced in accordance with applicable jurisdictional requirements. Where an earthquake-resistant structure is specified, additional considerations may apply.
- Floors **shall** be level before equipment is installed.
- If a wooden floor is to be used, ensure that the contractor's floor loading calculations take into account the type of equipment that will be installed, plus any future equipment. (See "Floor Loading" on page 3-9).



CAUTION

Equipment racks shall not be secured with screw lags into plywood alone.

- Floors **shall** be sealed to minimize the generation of airborne particulates. This is extremely important for a long equipment service life. Concrete and wooden floors may be finished using vinyl flooring. Concrete floors may also be sealed with an epoxy coating or equivalent (ANSI/TIA/EIA 569-B)
- Anti-static vinyl flooring is available for installations where equipment is vulnerable to electrostatic discharge (ESD). Care **shall** be taken when installing this type of flooring to ensure the integrity of the anti-static properties. Consult a contractor experienced with this type of flooring. See "Measures for Controlling Electrostatic Discharge" on page C-2 for proper grounding of anti-static flooring.

3.7 WEATHERPROOFING/SEALING

3.7.1 TRANSMISSION LINE ENTRY PORTS

Appropriate methods for entry of transmission lines into a building or shelter are as follows:

- An entry port specifically designed for cabling.
- PVC conduit, typically 102 mm or 127 mm (4 to 5 in.) diameter, allowing 50.8 mm (2 in.) protrusion at ends. If PVC is used, it **shall** be sealed using an appropriate all-weather silicone sealant between the conduit and the wall. The free space between the cables and the inside of the conduit should be packed with fiberglass insulation.
- Roof/wall feed-through.

In general, observe the following considerations for sites utilizing transmission line connections from an interior area to the exterior of a building or shelter:

- The entry of antenna transmission lines into a communications building or room requires a weatherproof, commercially made port assembly specifically designed for this purpose. These assemblies typically consist of a transmission line entry plate and boot assembly.
- A boot **shall** be used even if the cable is run through conduit. To avoid inconvenient rework in the future, it is recommended to select a transmission line entry plate with enough ports to accommodate the number of transmission lines at the site and allow for expansion.
- Entry plates should have 102 mm or 127 mm (4 or 5 in.) diameter openings. The plate is usually made of painted aluminum, with from one to 12 ports per plate. A single entry plate mounted on the outside wall or bulkhead is sufficient. See Figure 3-7.

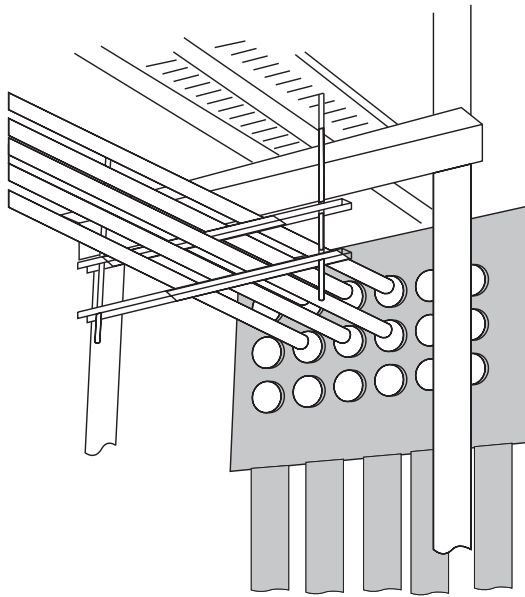

FIGURE 3-7 TYPICAL ENTRY PLATE

- Cable boots corresponding to the cable diameter(s) **shall** be used. Cable boots are sized for the transmission line they will carry and can be round, oval or rectangular. Some cable boots allow up to three small (12.7 or 22.2 mm (0.5 or 0.875 in.)) transmission lines to enter through one boot. The boot is usually made up of a two-piece cushion jacket, cushion (sized to cable diameter), and clamp set.
- To reduce heat loss from the building, two entry plates should be installed inside and outside, with rigid construction foam insulation between them. (Two sets of boots are then required.)
- The entry plate **shall** be installed per the manufacturer's instructions.
- The building/shelter and the port attachment to the building/shelter, **shall** be designed to prevent animals or birds from nesting in and around the entry ports.
- Transmission line entry ports **shall not** be used to feed through tower light power, building ground, or control cables.
- Boots **shall** be made of a material unaffected by ozone, sunlight, extreme heat, and cold.

- All unused ports in the entry plate **shall** be sealed with blank caps supplied by the port manufacturer.
- If a metallic port is used, it **shall** be bonded to the electrode grounding system. An integrated cable port **shall** be bonded to the external electrode grounding system.

3.7.2 SEALING OF BUILDINGS AND SHELTERS

To maintain optimum system performance and to avoid unnecessary HVAC costs, it is important to keep the communications site weather tight.



WARNING

Buildings and shelters that may have been open to the elements and animal infestations can pose health risks to personnel working in the structure. Avoid sweeping dry floors when rodent droppings may be present. Personnel occupying the site shall wash hands before eating and avoid touching mouth, nose, or eyes until site is sufficiently clean.

Animals and insects pose a threat to equipment and can cause health hazards to personnel. Accumulated rodent droppings can harbor hantavirus and other diseases. Hantaviruses are deadly airborne viruses spread by rodents. This threat **shall** be considered even more significant at remote sites in rural areas. Hantavirus infection can prove fatal in a few days without aggressive medical treatment. The best way to prevent hantavirus infection at a site facility is to assure that all site facility exterior openings are sealed. Floors in site facilities in rural locations should never be swept clean, but should be wet mopped to prevent airborne hantavirus contamination. A good practice when working at remote sites is to wash hands frequently and avoid touching your mouth and nose. To prevent the spread of disease and to prevent damage to equipment caused by nesting wildlife, observe the following requirements:

- All site buildings **shall** be weather tight and **shall** deter entry by animals, birds, and insects.
- If rodents are present within a site building or enclosure, the affected area **shall** be appropriately cleaned in a manner that is safe to personnel. Appropriate preventive measures **shall** be taken to remove and prevent further infestations. To prevent hantavirus infection, the floor **shall** be mopped in a safe and sanitary manner using a 5:1 water/bleach mixture.

For additional information on controlling the spread of hantaviruses, see the Centers for Disease Control website:

<http://www.cdc.gov/ncidod/diseases/hanta/hps/>

3.8 HEATING, VENTILATION, AND AIR CONDITIONING

One of the major considerations in site development is to maintain an environment in which the equipment can operate efficiently. A properly designed Heating, Ventilation, and Air Conditioning (HVAC) system provides the proper environmental conditions. Ambient temperatures inside the building or equipment room **shall** be maintained in a range within the specified requirements of each equipment. (All Motorola-manufactured products, as well as outsourced items that are drop-shipped per Motorola orders, have temperature, humidity, and cleanliness requirements, as listed in their respective manuals.)

Equipment manuals may specify either operating or ambient temperature. Operating temperature refers to temperature within the equipment case, with the equipment operating at a given capacity or load. Ambient temperature refers to the environmental temperature as typically measured 1.5 m (5 ft.) above the floor in the center of an adjacent aisle.

In lieu of manufacturer environmental standards, the site HVAC system **shall** be capable of maintaining interior conditions of 17.8° to 24° C (64° to 75° F) and reduce humidity to a level of 30 to 55% relative humidity (RH) (per ANSI/TIA/EIA-569-B or other applicable Standards body design requirements).

The variables involved in maintaining ambient temperatures include, but are not limited to, the following:

- Building construction
- Building size
- Type and amount of equipment installed at the site
- Ambient outside temperature
- Room size
- Number of entry ports (windows, doors, transmission line entry ports)
- Insulation
- Roof type (slope and construction material)
- Surrounding structures
- Use of a forced fresh air system
- Geographical location of the site

Design considerations should be made for equipment deployments and locations concerning operating limits of the equipment should the HVAC provisions fail. The facility backup generator **shall** be sized to accommodate the HVAC system.

With generator systems, a start-up delay kit is recommended on the HVAC system so that site AC power cycling or stand-by generator cut-over does not present a drop-out/brown-out condition which could stall and damage HVAC compressors.

The type and number of HVAC units required **shall** be calculated accurately. Due to the large number of variables involved, a single HVAC specification cannot be applied to all situations. Sizing of the HVAC system **shall** be performed by a HVAC engineering firm or the equipment shelter manufacturer's engineer.

3.8.1 HVAC DESIGN CONSIDERATIONS

The HVAC requirements for each site **shall** be evaluated on a site-by-site basis. It is advisable to include an expansion factor of at least 25% in the planning calculation, with consideration given to the final growth potential. With pre-fab buildings, provisions in the wall structure can sometimes be made such that another unit can be added in the field for additional growth.

Consider the following when working with the HVAC contractor to design the HVAC system:

- Obtain thermal loading for each piece of equipment from the appropriate engineering personnel and provide it to the building manufacturer HVAC engineering or HVAC contractor. Motorola System Planners typically provide heat generation information in BTU and Watts.

- Obtain site specifications for construction materials, insulation type and R values, size, existing conditions, and predicted growth.
- In areas with a history of Moment Magnitude rating 3 or greater, seismic considerations for the HVAC system **shall** be addressed by the HVAC engineering firm or contractor. Typically, additional flexible bracing can be provided to prevent HVAC equipment from tipping or shifting position. Flex hoses or semi-rigid hoses with strain relief should be provided to prevent mechanical stress failure.
- Only HVAC equipment that uses chlorofluorocarbon-free (CFC-free) coolant **shall** be used for new installations.
- It is recommended that the HVAC system be alarmed. If the site has an alarm system, each HVAC unit installed at a site **shall** be connected to the building alarm system, so that the total shutdown of any HVAC unit results in an alarm.
- HVAC filters must always be used and maintained on a regular schedule in order to maintain a clean environment and prevent dust and contaminants entering into electronic equipment.

3.8.1.1 WALL-MOUNTED HVAC UNITS

Observe the following general considerations for wall-mounted HVAC units:

- Self-contained wall mounted HVAC units are acceptable in most applications, but use care in selecting the proper unit size for the projected BTU heat load. If more than one unit is required, plan to provide sufficient wall mounting space.
- Only commercial-grade HVAC units **shall** be used. Consumer-grade household units or window-mounted units **shall not** be used.
- To reduce operating costs and prevent the compressors from freezing during cold weather, all units should be equipped with heating elements and an economizer which allows the site to be cooled by outside air if the outside temperature falls below a predetermined value.
- HVAC systems using outside air circulation features may not be suitable for environments having unusually high dust or particulate emissions.
- Redundant HVAC units **shall** be installed and available as a backup in case one unit fails or a single unit may be used if it is alarmed to a remote terminal. All redundant HVAC units should be designed in a lead-lag configuration to cycle with the primary unit in order to subject all units to equal wear.
- If two HVAC units are required to provide sufficient cooling, one additional unit should suffice for redundancy.
- Local fire codes may require an automatic shutdown circuit for HVAC units should the smoke/heat alarm activate.

3.8.1.2 EXHAUST FANS

- It is advisable to install a thermostatically-controlled exhaust fan at some sites, to remove excessive heat buildup if air conditioning units are disabled or fail.
- Locate the exhaust fan as high as possible in the structure to remove the maximum amount of heat.
- A corresponding filtered exterior cold air inlet vent with motorized louvers should be installed low on an opposing wall to allow unobstructed air flow through the site.
- The inlet of the fan **shall** be protected with a screen barrier to prevent the entry of insects, birds, or animals.

- To prevent excessive dirt and/or humidity from entering the building, the exhaust fan is intended to be used only as an emergency backup.
- Battery and generator rooms require special concerns regarding exhaust requirements. See “Battery Systems” on page 6-27 for additional information.
- Louvered entries into building or shelter may present a security risk due to ease of unauthorized entry through the louver assembly. This concern should be considered in the overall security plan for the site.
- Design of motorized louver systems **shall** comply with NFPA shutdown requirements. Exhaust fans and HVAC systems **shall** automatically shut down and the exterior wall vents automatically close during fire alarm activation and fire suppressant release. See NFPA 12 for additional information.

3.8.1.3 HEAT PUMPS

In sites where heat levels are too high for the use of wall-mounted units, commercial-grade heat pumps may be used. Appropriateness of using a heat pump system **shall** be determined by the contracted HVAC engineering firm or contractor. Heat pumps are also used in shared sites or where an exterior wall is not available for installation of a stand-alone HVAC unit. The compressor is separate from the control units and **shall** be mounted on either a pad on the roof of the structure or on a concrete pad outside the building.

Per NFPA 70-2005, Article 210.63, a 15- or 20- ampere-rated receptacle outlet is required for maintenance of the heat pump. A ground fault circuit interrupter (GFCI) receptacle is also required within 7.5 m (25 ft.) for maintenance. All units should be equipped with a start control option to avoid compressor damage during short power outages.

3.8.1.4 THERMOSTATS

Thermostats **shall** be installed in locations where room ambient temperature can be best and most evenly controlled. The placement and number of thermostats should be determined by the contracted HVAC engineering firm.

3.8.1.5 TEMPERATURE ALARM

To avoid down time and possible equipment damage due to temperature extremes, it is recommended that all sites be equipped with high and low temperature alarms. These alarms should interface with the site security system and be monitored around the clock. The sensors **shall** be accurate enough to detect temperature variations within the range of 5° to 33° C (40° to 90° F).

3.8.1.6 MAINTENANCE

It is recommended that the customer establish a preventive maintenance program with an authorized local HVAC service company to provide service and repair. The agreement should include periodic cleaning and filter replacement. The back-up HVAC unit should be periodically exercised, or alternatively, an equal-sharing duty cycle can be used.

3.9 SPECIAL CONSIDERATIONS FOR TELEPHONE CENTRAL OFFICES AND SWITCH ROOMS

The same building design requirements for general communications sites apply to switch room, iDEN Mobile Switching Office (MSO), major dispatch centers, or central office (CO) design, but on a more critical scale. For example, a CO may contain a cellular or Personal Communications Services (PCS) switch and/or centralized base station controllers. Good design is even more critical for a CO because the CO can be the overall controlling entity of an entire system, and thus can cause system-wide failure if there is a problem.

3.9.1 LIGHTNING DAMAGE PREVENTION

Although perhaps more costly, the most effective way of protecting the CO switch from lightning damage is to locate it separately from a communications site and accompanying tower at the same facility. Not only is the CO switch much more expensive to replace than typical communications equipment, but the entire system will fail if the CO switch fails. The initial extra cost of building a separate communications site at the CO location is far less expensive than revenues lost if the entire system fails due a damaged CO switch caused by a lightning strike to the radio tower.

3.9.2 POWER SOURCE PROTECTION

- Ideally, it is preferable to have separate, redundant power feeders from the power company serving the switch room. These should be fed from two different substations, so that the failure of one substation will not cut off power to the CO.
- Co-located business office function may also be considered with priority. Because most CO equipment is served by DC power systems, a large battery system, perhaps even in a redundant configuration, should be considered. This not only provides backup power in case of generator failure, it also provides a means of absorbing surges on the DC circuits that may occur if the site has to switch to generator power.
- Terminals communicating with the switch can be served by either individual UPS plants, or a centralized, overall system. This keeps switching transients from interrupting terminal operation.
- Surges transferred over the power lines during normal operation **shall** be drained by primary and secondary surge suppressors installed in a configuration that accommodates the generator circuits. See Chapter 7, “Surge Protective Devices.”
- It is recommended to have a CO, Dispatch center, etc. served by fiber optic T-1, T-3, OC-3, and higher capacities. This provides additional lightning protection by removing the copper connection from the phone company to the switch and provides optical isolation from ground potential rises (surges) that can occur on the copper connections.

3.9.3 CENTRAL OFFICE LAYOUT

When first installing equipment into a new large switch room, the equipment layout **shall** be planned to allow for sufficient aisle space, but be efficient so future expansion capacity is maximized. The initial layout should be designed to accommodate the absolute maximum number of equipment racks while allowing adequate space between aisles and at end of aisles.

Minimizing the overall distances of the DC power system and the grounding layout should be a priority.

The control room housing the switch terminals should be isolated from the rest of the equipment to provide noise reduction for those continually working in this environment. This room should also be configured as an Isolated Ground Zone (IGZ).

3.10 CABLE TRAYS

This section provides requirements and installation guidelines for cable trays. Cable trays should be used to support communications cabling within buildings and shelters.

Cable trays provide proper support of cables between cabinets, relay racks and bays of equipment and help maintain adequate separation between the cable groups. The orderly separation and support of cable also simplifies maintenance. Cable management over relay racks and equipment cabinets can be accomplished by utilizing cable tray systems. These tray systems are designed to provide support, routing, parallel separation and securing of wires and cables as defined in “Cabling Requirements for Cable Trays or Ladders” on page 9-14. As defined in NFPA 70-2005, Article 392, a cable tray or tray system is a unit or assembly of units or sections and associated fittings forming a rigid structural system used to securely fasten or support cables and raceways.

NOTE: Aluminum ladders designed for climbing **shall not** be used as cable trays.

3.10.1 CABLE TRAY SELECTION

Two types of overhead cable tray systems which are suitable for use as cable support are:

- Steel stringer style ladder
- Aluminum or steel ladder style cable tray

Steel stringer style ladders come in various designs and styles. Typically they are available in C-channel, tubular and solid bar in painted or yellow zinc dichromate finishes. Stringers are typically 38.1 mm (1.5 in.) to 51 mm (2 in.) in depth, and vary in length. Rungs should be spaced at least 229 mm (9 in.) apart. Simple hardware is used to make “T” and cross connections.

“J-bolts” (threaded, formed metal rods bent into a “J” shape) **shall not** be used as fasteners for cable trays. These rods typically deform when stressed, possibly allowing cable trays to drop. Captive hardware such as threaded bolt, washers, and nuts are recommended.

Aluminum or steel cable tray systems also come in various designs and styles such as ventilated trough, solid trough and ladder type with “I” beam or C-channel siderails. The most practical is the ladder type. The major difference between the stringer style ladders and tray systems is that a tray has a siderail or wall height from 102 mm (4 in.) to 178 mm (7 in.). This load depth may be desirable for large bundles of cables or transmission line routing. The siderail height affects overall rack to cable tray to ceiling dimension restrictions as outlined in this chapter. A rung spacing of 229 mm (9 in.) is also recommended for this tray type. This type of tray system requires prefabricated Ts, bends, crosses and reducers, which must be factored into the system design.

Both types of tray are available in widths ranging from 102 mm (4 in.) to 1.06 m (42 in.). Typically, widths of 457 mm (18 in.) and 610 mm (24 in.) are used. Stacking of 457 mm (18 in.) wide trays is allowed, but ceiling height requirements and clearances **shall** be adhered to. Cable support system design **shall** provide for maintaining a spacing of 457 mm (18 in.) between trays.

The overall sizes of cables, numbers of cable, and number of cable groups required in a run **shall** be considered when specifying tray width. Account for a minimum of 152.4 mm (6 in.) loss of width for cable group spacing in itself.

NOTE: In all cases the width of the cable tray **shall not** be less than 457 mm (18 in.) and is recommended to be 610 mm (24 in.).

3.10.2 CABLE MANAGEMENT UNDER RAISED FLOORS

NOTE: Do not mix aluminum and steel tray types at a facility installation.

For wire management under raised computer floors, a welded wire mesh cable tray system is recommended. This type of tray system can be mounted to, or suspended from, raised floor pedestals or sub flooring. This tray system typically consists of high strength steel wire in the form of a 50 x 100 mm (2 x 4 in.) mesh. The finishes can be electro-plated zinc galvanized or stainless steel that are suitable for all environments. Bends can be fashioned by cutting the mesh with a bolt cutting tool and simple hardware connections to the wire mesh. Manufacturers can supply bonding terminations and outboard ground cable supports for proper tray system grounding.

3.10.3 WIRE-MESH CABLE TRAYS

In general, observe the following considerations when in selecting cable trays. See “Cable Trays” on page 5-45 for proper cable tray grounding practices. All trays whether above racks or below raised floors require the same grounding practices.

- Noting the amount of cables to be supported by each run, cable tray width **shall** be selected to provide 50.8 mm (2 in.) minimum separation between cables or cable groups. 457 mm (18 in.) trays or double-deck ladders may have to used in some cases.
- Steel stringer and steel tray systems **shall** utilize an extended post to attached grounding conductors. This post should extend 102 mm (4 in.) to 152.4 mm (6 in.) either horizontally or vertically from the siderail of the tray, with no less than 457 mm (18 in.) of spacing between posts.
- If AC power cables are to be run in cable trays, cable separation and special considerations **shall** be maintained.
- The size, weight, and projected expansion of the system **shall** be considered to ensure proper tray usage. The “hang” test **shall not** be used.
- The number and function of conductors to be placed within a cable tray **shall** be considered before procuring cable trays.
- It is recommended that only cable trays specifically designed for communications purposes be used (as opposed to standard electrical cable trays).

- A rung type cable tray may be more suitable in instances when only a single line of supports is available and cables can be laid in from a specific side.
- A solid bottom cable tray with a hinged cover may be desirable for use between a tower and building, to provide complete enclosure of the cables and minimize the potential for damage and vandalism. Unless specifically designed to also function as an ice bridge, a cable tray **shall not** be used instead of a standard ice bridge.

3.10.4 CABLE TRAY LAYOUT AND DESIGN

In general, the following considerations must be observed when preparing the layout of cable trays:

- If the building has a sprinkler system, ensure the cable trays do not block the sprinklers. Cable trays **shall not** be placed under smoke detectors or sprinkler heads.
- The cable tray system **shall** be designed to accommodate cable distribution throughout the equipment area. Continuity of the cable tray system and support for the cables **shall** be maintained.
- The cable tray system **shall** use the proper sections as designed by the manufacturer. Straight sections, elbows, tees, dropouts, and expansion connectors **shall** be used as required within the system.
- The cable tray system **shall** be designed with suitable strength and rigidity to provide adequate support for all contained wiring.
- Due to thermal contraction and expansion, cable tray systems may require the use of expansion connectors.
- Cable trays and troughs may extend through walls or floors providing the installation is made so that the possible spread of fire or products of combustion will not be substantially increased.
- Openings through fire resistant walls, partitions, floors, or ceilings **shall** be firestopped using an approved method to maintain the fire resistance rating.
- Cable tray systems **shall** be designed for installation at heights that provide clearances adequate to install the necessary equipment with provisions for expansion.
- Factors such as ceiling height, light fixture locations, cable entry ports, equipment location and minimum cable bending radius must be considered during design and layout.
- Cable trays should not be placed under lights or electrical fixtures or boxes.
- A minimum of 152.4 mm (6 in.) between the top of an equipment rack/cabinet and the bottom of the cable tray **shall** be maintained.
- A minimum of 305 mm (12 in.) above the top of the cable tray and the ceiling **shall** be maintained. The above two dimensions are required at all new sites. If at an existing site with a lower ceiling, good engineering practices are required
- When AC power distribution is to be combined with the cable tray system, the AC power raceway **shall not** be supported by or supported from the cable tray system unless the cable tray system is manufactured and approved for this purpose. The AC power raceway may be supported by a trapeze arrangement with the cable tray attached to the top of the trapeze and the AC power raceway attached to the bottom of the trapeze. The trapeze arrangement is supported from the ceiling and/or sidewalls.
- The entire system **shall** be rigid, immovable and properly secured in place. Manufacturer's specifications as well as the NFPA 70-2005, Article 392 and any other applicable national, state, jurisdictional, and local codes **shall** be followed.

3.10.5 CABLE TRAY INSTALLATION

Observe the following general considerations when installing cable trays:

- Cable trays **shall** be securely supported to the ceiling and/or wall such that they are immovable. These supports **shall** provide a strength and working load capacity sufficient to meet the load requirement of the cable tray system.
- Horizontal and vertical supports should provide an adequate bearing surface for the cable tray and should have provisions for hold-down clamps or fasteners. There may be additional requirements for active seismic areas (Moment Magnitude 3 or greater), such as wooden headers at wall connections. It is recommended in these cases that cable tray ends be attached to walls using a 50.8 mm x 102 mm (2 x 4 in.) wooden header. The header may be nailed along the wall approximately 305 mm (12 in.) below the ceiling. This provides a blunt attachment point which will prevent the somewhat sharp ends of cable trays from penetrating the walls. Seams between multiple cable tray sections run across a room should be staggered so that if a seam fails, the entire cable ladder system will not fail.
- A support **shall** be located within 610 mm (2 ft.) of each side of an expansion connector. Cable tray systems **shall not** be used as incidental support for other raceways or equipment.
- Cable trays **shall** be positioned such that they are easily accessible with sufficient space provided above and around the cable tray to permit adequate access for installation and maintenance of cables.
- Cable trays **shall not** have any sharp edges, burrs or projections that may damage cables.
- All cable tray sections **shall** be electrically bonded together by an approved method and connected to the building ground system. (See Figure 3-8.) See “Cable Trays” on page 5-45 for additional information. The cable tray system **shall** be grounded to the room single point ground position (MGB) only.
- Manufacturers' specifications relating to the installation of cable trays as well as NFPA 70-2005, Article 392 and any other applicable national, state, jurisdictional, and local codes **shall** be followed.

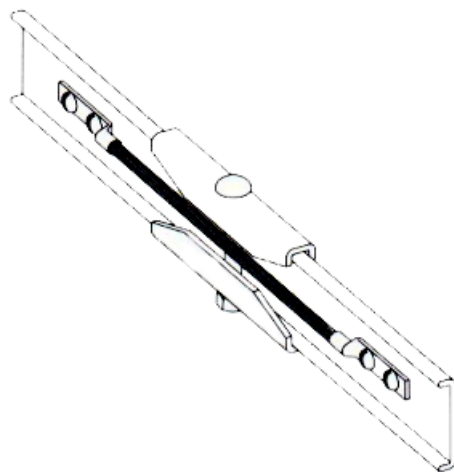

FIGURE 3-8 CABLE TRAY BONDING CONDUCTOR

3.10.6 CABLE TRAY SAFETY CONSIDERATIONS

Cable tray systems **shall not** be installed at heights or in positions that **shall** pose a hazard to service personnel working within the site.

At no time **shall** the cable tray system be used as an incidental support or walkway.

Threaded support rods **shall not** extend below the tray bottom further than the required fittings and **shall** include appropriate protective end caps.

3.11 LIGHTING

All lighting **shall** follow the applicable requirements of NFPA 70-2005, Article 410, and any other applicable national, state, jurisdictional, and local code requirements. Interior lighting requirements are based upon a number of considerations, including:

- Adequate lighting for a safe and efficient work environment. Placement should assure illumination behind tall rack cabinets.
- Energy efficient design
- Low heat generation characteristics
- Exterior lighting requirements are concerned with lighting for points of entry and exit from the building and for perimeter security.
- Lighting on remote sites can be seen for miles at night and in some cases, may cause objections from neighbors. To address these issues, on-demand systems such as infrared proximity sensors and twist-knob timers are highly recommended. Bright lights (including lights used on photocell controllers) can, in some cases, produce neighbor and environmentalist complaints.
- In all cases, incandescent or fluorescent lighting may be used.

3.11.1 GENERAL INTERIOR LIGHTING SPECIFICATIONS

In locations that are considered hazardous because the atmosphere does or may contain gas, vapor or dust in explosive quantities, special application fixtures **shall** be used. These fixtures **shall** be rated for use in Class I, II and III, Division 1 and classified areas. These fixtures **shall** comply with NFPA 70-2005, Articles 500 through 506.

In applications where fixtures are susceptible to dislodgment, or where tube breakage may represent a hazard to personnel or equipment, shatterproof fluorescent tubes or safety tubes **shall** be used. Seismic and industrial practices require that fluorescent lamp protectors be installed over lighting to prevent falling glass or accidental damage to lamps.

If incandescent lighting is used, industrial-grade protective covers **shall** be used.

3.11.2 INTERIOR LIGHTING QUALITY

Interior lighting **shall** produce a minimum of 500 Lux (50 foot-candles) measured 1 m (39.4 in.) above the finished floor in the middle of all aisles between cabinets or racks. See ANSI/TIA/EIA 569-B for additional information.

3.11.3 EMERGENCY INTERIOR LIGHTING

- Emergency backup lighting units **shall** be installed to activate immediately upon loss of all AC power in all equipment shelters and tenant improvement equipment rooms within a building.
- Each unit **shall** be equipped with a self-test button or switch.
- Each unit **shall** have a minimum of two lamps. Lamps may be sealed beam or tungsten halogen.
- Batteries **shall** be sealed, maintenance free, and provide a minimum of 90 minutes of emergency power.
- All emergency lights **shall** be UL approved and meet all OSHA, NFPA 101, and any other applicable national, state, jurisdictional, and local life safety code requirements.
- Emergency lights installed in harsh environments **shall** meet all requirements for NEMA 1, 2, 3, 3R, 3S, 4, 4X, and 12 ratings.
- The lights **shall** be located to illuminate any and all doorways and exits.
- Exits **shall** be labeled with illuminated signs reading EXIT. Pathways to exits **shall** be marked.
- Emergency lighting within high-rise buildings may require that it be powered from a house power source, and that the emergency lighting be connected to the house master alarm system.

3.11.4 EXTERIOR LIGHTING

- One exterior light **shall** be installed near the door to provide lighting for personnel entering and exiting an equipment shelter. The fixture **shall** be type NEMA 3, weather resistant and suitable for general outdoor application.
- If floodlights are installed to provide yard/perimeter security lighting, the following requirements **shall** be met:
 - UL approved Quartz and High Pressure Sodium lighting elements **shall** be used.
 - Mercury Vapor and Metal Halide lamps **shall not** be used. These lamps can cause serious skin burns and eye inflammation from short-wave ultraviolet radiation if the outer envelope of the lamp is broken or punctured.
 - An automatic photo-control switch, with a manual override, can be used to turn the lights on at dusk and off at dawn if desired.
 - Fixtures **shall** meet NEMA heavy duty type classification and be UL listed for use in wet locations.

3.12 FIRE PROTECTION/SAFETY

- The primary intent in suppressing a fire at a communication site is to protect lives. Equipment protection is secondary. If the fire is expected to be entirely suppressed by a manual extinguisher, then the suppression effort can be made, but in no circumstances **shall** fire suppression be attempted in order to save equipment when personnel safety is at risk. In all cases for occupied shared buildings, the fire department and tenants **shall** be notified immediately of the fire.
- Fire extinguishers can represent an important segment of any overall fire protection program. However, a proper fire suppression program success depends upon the following general conditions:

- The extinguishers are of the proper type and size for a fire that may occur.
- The extinguishers are properly located and identified.
- The extinguishers are in working order and properly maintained.
- Employees have a clear understanding of their functional operation.
- Safety awareness has been made available.

3.12.1 REFERENCE PUBLICATIONS

The following are suggested reference publications regarding fire suppression systems:

- NFPA Fire Code, Volume 1
- NFPA 10
- NFPA 12 Standard on CO₂ extinguishing systems
- NFPA 13 Standard for installation of sprinkler systems
- NFPA 17 Standard for Dry Chemical Extinguishing system
- NFPA 2001 Standard on Clean Agent Fire Extinguishing Systems
- CAN4-S503-M83 Standard for CO₂ fire extinguishers
- CAN4-S504-77 Standard for Dry Chemical fire extinguishers
- ULC-S504-77 Standard for Dry Chemical fire extinguishers
- ANSI/UL 154 Standard for CO₂ fire extinguishers
- ANSI/UL 299 Standard for Dry Chemical extinguishers

3.12.2 TRAINING AND PROPER USAGE

Site personnel **shall** be familiar with the proper usage of the fire protection equipment provided at the site. Documentation supplied with the equipment **shall** be made available to personnel. Responsible personnel **shall** fully understand the content of such documentation.

More complicated systems, such as an installed automatic system, should be supported with training supplied by the vendor.

3.12.3 MINIMUM REQUIRED FIRE EXTINGUISHERS

All installations **shall** have a minimum of two correctly installed portable fire extinguishers on the premises before equipment is installed. At a minimum, the following size and classification of portable extinguishers are required:

- 9 kg (20 lb.), Class ABC, dry chemical extinguisher (for general fire fighting)
- 3.2 - 4.5 kg (7 - 10 lb.), Class BC, Carbon Dioxide (CO₂) extinguisher (for equipment fire fighting) or FE-36™ 4.54 kg (10 lb.)

Review the requirements of NFPA 10 or applicable jurisdictional/ local regulations to determine the need for additional extinguishers based on site size and special considerations. Depending on the size of the site building, additional extinguishers may be required.

3.12.4 REQUIRED STANDARDS FOR PORTABLE FIRE EXTINGUISHERS

Portable fire extinguishers **shall** be listed and labeled, meet or exceed all the requirements of the fire test standards, and meet the appropriate performance standards listed below.

- Fire Test Standards: ANSI/UL 711, CAN/ULC-S508-M90
- Performance Standards:
 - Carbon Dioxide Types: ANSI/UL 154, CAN/ULC-S503-M90
 - Dry Chemical Types: ANSI/UL 299, CAN/ULC-S504-M86
- In an electronic equipment enclosure or room, an FE-36 (or equivalent) or CO₂-type extinguisher is required. These extinguisher types minimize secondary damage caused by dry chemical agents used in most Class ABC extinguishers. The dry chemical agents contain very fine alkaline-based powders that can cause severe equipment damage due to corrosion. The potential for damage is not just limited to the involved equipment, but may affect all other electronic equipment in the enclosure. The dry chemical extinguishers can also obscure visibility in a closed room, making egress difficult. The dry chemical extinguisher should be considered as the second line of defense if the fire cannot be extinguished with an FE-36 or CO₂-type extinguishers.

3.12.5 FIRE EXTINGUISHER INSTALLATION

When installing fire extinguishers, the following requirements **shall** be observed:

- Portable fire extinguishers **shall** be maintained in a fully charged and operable condition, and stored in their designated places at all times when they are not being used.
- Fire extinguishers **shall** be conspicuously located where they are readily accessible and immediately available in the event of a fire. Preferably, extinguishers **shall** be located along normal paths of travel, including exits from areas.
- Fire extinguisher locations **shall** be clearly marked. Acceptable means of identifying the fire extinguisher locations include arrows, lights, signs, or coding of the wall or column.
- If more than one fire extinguisher is located in the same location and they are intended for different classes of fires, the intended use of each extinguisher **shall** be marked conspicuously to aid in the choice of the proper extinguisher at the time of a fire.
- Cabinets housing fire extinguishers **shall not** be locked.
- Fire extinguishers **shall not** be obstructed from view.
- Portable fire extinguishers (other than wheeled types) **shall** be securely installed in the hanger or in the bracket supplied or placed in cabinets or wall recesses. The hanger or bracket **shall** be securely and properly anchored to the mounting surface in accordance with the manufacturer's instructions.
- Fire extinguishers installed under conditions where they are subject to dislodgment **shall** be installed in brackets specifically designed to retain the extinguisher.

- Fire extinguishers having a gross weight not exceeding 18.14 kg (40 lb.) **shall** be installed so the top of the fire extinguisher is not more than 1.53 m (5 ft.) above the floor. Fire extinguishers having a gross weight greater than 18.14 kg (40 lb.) (excluding wheeled types) **shall** be so installed that the top of the fire extinguisher is not more than 1.07 m (3.5 ft.) above the floor. In no case **shall** the clearance between the bottom of the fire extinguisher and the floor be less than 102 mm (4 in.).
- Extinguisher operating instructions **shall** be located on the front of the extinguisher and be clearly visible. Hazardous materials identification systems (HMIS) labels, six-year maintenance labels, hydrotest labels, or other labels **shall not** be located or placed on the front of the extinguisher.
- Fire extinguisher mounted in cabinets or wall recesses **shall** be placed so that the fire extinguisher operating instructions face outward. The location of such extinguishers **shall** be conspicuously marked.

3.12.6 FIXED FIRE DETECTION, ALARM, AND SUPPRESSION SYSTEMS



WARNING

Fixed or portable fire suppression systems using water shall not be used in communication sites.

This section specifies minimum requirements for fire detection, alarm, and suppression systems. For additional requirements, see NFPA 12, NFPA 2001, and any other applicable national, state, jurisdictional, and local code requirements that may apply. Specifically, fixed systems comprise the following:

- Detection systems
- Alarm systems
- Automatic suppression systems

Any work involving installation of these systems **shall** be performed only by personnel skilled in this work (typically a contractor specializing in these systems). This section is provided to aid personnel charged with purchasing, inspecting, testing, approving, operating, and maintaining this equipment in their consultations with an appropriate, contracted fire protection engineering firm.

Some communications equipment systems include detectors and alarms that transmit to centralized control centers within the system itself. High-rise buildings often utilize a second dedicated facility alarm and can be included as part of a central alarm system connected to the local fire department.

3.12.6.1 AUTOMATIC FIRE DETECTION

Automatic fire detection **shall** be accomplished by any listed or approved method or device capable of detecting and indicating heat, flame, smoke, combustible vapors, or an abnormal condition in the controlled area that is likely to produce fire. On large installations the fire detection system **shall** consist of a combination ionization smoke detector and a rate compensated fixed temperature thermal detector. This type of two-loop detection system will provide a positive verification of a fire condition and the earliest possible pre-alarm notification. The detector units **shall** conform to UL 268 standards (or equivalent requirements for the site area). If the fire detection system is the type that shuts off power to the installation, battery operated emergency light sources **shall** be provided in the affected areas.

3.12.6.2 AUTOMATIC ALARMS

Automatic alarms or indicators (or both) indicate the operation of the system, hazards to occupants, or failure of any supervised device. The type (audible or visual), number, and location of these devices **shall** be such that their purpose is satisfactorily accomplished. As a minimum, the fire alarm system **shall** give an initial warning signal for evacuation of occupants and for confirmation of a fire condition. A secondary alarm system **shall** sound, indicating the automatic discharge of a fire-extinguishing agent. The system **shall** have a time delay function between the two warning signals which can be adjusted to provide adequate time for evacuation or abort procedures.

3.12.6.3 SITE ALARM SWITCH FORM

Site alarms are defined as any action, reaction, or determinations associated with diagnostics, security, or emergency. All equipment providing alarms will send alarms from the equipment utilizing dry-contact closures. The dry contact closures will conform to Form-C configuration, providing Common, Normally-Open, and Normally-Closed contacts. The outputs will not be referenced to either ground or any voltage potential.

3.12.6.4 AUTOMATIC SUPPRESSION SYSTEMS

Automatic suppression systems automatically discharge fire-extinguishing agents when a fire condition is detected. With use of control panels, directional valves and flow control equipment, these systems can be used to protect against one or more hazards or groups of hazards. Where two or more hazards may be simultaneously involved in the fire by reason of proximity, both hazards **shall** be protected with separate individual systems and the combination arranged to operate simultaneously. The other option is that they could be protected with a single system that **shall** be sized and arranged to simultaneously discharge on all potentially involved hazards that have indicated an alarm condition. A qualified fire protection engineer **shall** be consulted when designing automatic extinguishing systems.

If an overhead sprinkler system is used, the “dry pipe” type **shall** be used. Upon detection of a fire condition, this type of system removes source power to the room and then opens a master valve to fill the overhead sprinklers. These systems sometimes use a primary suppressor such as CO₂, releasing before the sprinkler system is activated. Dry pipe systems can have enough of a delay so that a manual reset can be provided, if allowable. This system is preferable to a “wet” type system, which has the chance of water leakage and resultant equipment damage, and can possibly use rancid water that has been stored in overhead pipes for long periods.

If power connections are made beneath raised floors, waterproof electrical receptacles and connections **shall** be used in all types of installations.

3.12.7 WARNING SIGNS

Appropriate warning signs **shall** be affixed outside of areas where concentrations of extinguishing gases can accumulate. This should not be limited to just protected spaces but in the adjacent areas where the gases could migrate or leak (such as the storage room for the gas containers, adjacent rooms and hallways). There **shall** be a warning sign posted at the entrance to the protected area and inside the protected space.

3.12.8 POWER SOURCES

The primary power source for the fire extinguishing system's operation and control **shall** have the capacity for intended service and **shall** be reliable. Where failure of the primary power source would jeopardize the protection provided, a secondary (standby) power source **shall** supply energy to operate the system for a period of 24 hours and be capable of operating the extinguishing system continuously for the full designed discharged period. The secondary (standby) power **shall** automatically transfer to operate the system within 30 seconds of the loss of primary power.

3.12.9 FIXED SYSTEMS COMPARISON

If a new system is being installed or an existing fixed fire-extinguishing system is being replaced, always check with local fire prevention authorities and a competent fire protection engineer first. Be ready to supply information about the material composition of the building or housing structure, occupancy of the structure, environment, and equipment that needs to be protected. Ask for their recommendations on the type of extinguishing systems needed, along with any advantages and disadvantages of a particular system.

Some of the more common fixed systems currently used at communication sites are listed in Table 3-2. The advantages and disadvantages of each type are also described.

TABLE 3-2 FIRE SUPPRESSION SYSTEMS

Type	Advantages	Disadvantages
Water Extinguishing (Water Sprinkler)	<ul style="list-style-type: none"> • Upon detection of a fire condition, a “dry pipe” type of system removes source power to the room and then opens a master valve to fill the overhead sprinklers. (The “dry pipe” system is preferable to a “wet pipe” system, which has the chance of water leakage and resultant equipment damage and possible electrical shock.) • No adverse environmental impact. 	<ul style="list-style-type: none"> • If power connections are made beneath raised floors, waterproof electrical receptacles and connections are required. • Either type of water sprinkler system could cause electronic equipment damage and will require an extensive cleanup effort. • Upon discharge, system downtime can be lengthy.
Clean Agent Extinguishing System		
FE-13™ (HFC-23)	<ul style="list-style-type: none"> • Environmentally friendly replacement of Halon™ 1301-based systems. • Advantage over CO₂ systems, due to FE-13 lack of oxygen displacement characteristic. • Electrically nonconductive and residue-free. No cleanup is required after discharge and system downtime can be kept to a minimum. • The storage cylinder(s) may be stored away from the protected area. • Storage cylinders can be stored in a wide range of temperatures; containers need not be stored in protected places at room temperature. • System recharge is less expensive than alternative fluorocarbon agents. 	<ul style="list-style-type: none"> • May not be readily attainable or easily refilled in certain areas. • Typically much more costly to purchase and maintain than water systems. • When released under fire conditions hydrofluoric acid (HF) can be produced.

TABLE 3-2 FIRE SUPPRESSION SYSTEMS (CONTINUED)

Type	Advantages	Disadvantages
FM-200™ (HFC-227ea)	<ul style="list-style-type: none"> • Environmentally friendly replacement of Halon 1301-based systems. • Less toxic than Halon 1301. • Electrically nonconductive and residue-free; no cleanup is required after discharge. System downtime can be kept to a minimum. • When compared with Halon 1301, FM200 systems require minimal additional floor storage space. 	<ul style="list-style-type: none"> • System recharge can be more expensive than other types of extinguishing agents. • When released under fire conditions hydrofluoric acid (HF) can be produced.
INERGEN™ (IG-541)	<ul style="list-style-type: none"> • Environmentally friendly replacement of Halon 1301-based systems. It has no Ozone Depleting Potential, Global Warming Potential, or Atmospheric Lifetime. • No toxic or corrosive decomposition products. • Electrically nonconductive and residue-free; no cleanup is required after discharge. System downtime can be kept to a minimum. • Because INERGEN is stored as a gas, it can be stored at a substantial distance from the risk area, where more space is available. 	When compared with Halon 1301 and FM200 systems, INERGEN systems require more cylinders and additional floor storage space.

3.13 SAFETY EQUIPMENT

The following safety equipment **shall** be permanently located inside all equipment shelters and in or within close proximity to tenant improvement equipment rooms:

- First aid kits
- Eye wash station
- Battery safety equipment including personal protection equipment in any area with wet cell batteries
- Construction/installation safety equipment
- Safety markings and barriers

NOTE: It is strongly recommended that all employees obtain formal training and certification in First Aid and cardiopulmonary resuscitation (CPR).

3.13.1 FIRST AID KIT

- Because many communications facilities are located in areas far from medical help, a first aid kit **shall** be present at every site.
- All first aid kits, case, and contents **shall** meet or exceed the specifications of ANSI Standard Z308.1.
- All first aid kits **shall** be mounted in a conspicuous, easily-accessible location.
- The first aid kit case **shall** be durable, rustproof, and allow for wall mounting.

3.13.2 TYPICAL BATTERY SAFETY KIT

Where required by OSHA or applicable jurisdictional or local codes, the following equipment **shall** be supplied:

- A lightweight, acid resistant bib type apron **shall** be permanently stored on site near the battery plant. The fabric **shall** be acid, caustic, puncture, and flame resistant.
- An acid resistant, full face shield, **shall** be permanently stored on site near the battery plant. The shield **shall** meet all requirements of ANSI Z87.1. Protective eye wear that does not provide full face protection **shall not** be allowed.
- One pair of acid resistant gloves **shall** be permanently stored on site near the battery plant. These gloves **shall** be of sufficient length to cover the hand, wrist, and forearm for protection from chemical splash.
- One 0.5 kg (1 lb.) box of baking soda or equivalent acid neutralizing compound **shall** be permanently stored on site near the battery plant.
- Water is to be provided to mix with the baking soda.
- An OSHA-approved emergency eyewash station **shall** be permanently mounted near the battery plant. The eyewash station **shall** use an isotonic saline wash capable of neutralizing acids or caustics and **shall** be able to flush the eye for 15 minutes. A plumbed eyewash station and a shower should be provided in battery areas if possible.

NOTE: Discard and replace bottled eyewash solution according to the expiration date on the bottle.

3.14 ON SITE COMMUNICATIONS

It is required that some form of two-way communications be available at each facility, for safety reasons as well as for performing maintenance and troubleshooting. Most outages occur after hours and normally only one technician is dispatched to perform repairs. Cellular phones may only be used if there is known coverage at the location.

- Important numbers **shall** be posted on or near the entrance door such as but not limited to:
 - Police, ambulance and fire personnel
 - Site owner

- For maintenance and troubleshooting, a telephone or microwave orderwire is invaluable, if monitored. In most cases the technician must contact a central support group and/or a computer in order to obtain help. Many new systems require a communications link to download the operational information in order for the equipment to function.
- Note that neither a mobile radio in a maintenance vehicle nor a personal portable radio should routinely be used for onsite communications requirements.
- On-site communication between personnel on the ground and any personnel working on a tower **shall** be maintained at all times.

3.15 SIGNAGE

An equipment room entrance door, roof entrance door, shelter, enclosure, tower or site compound **shall** be posted with signs identifying the site and providing notices and warnings. The types of site signage **shall** be in accordance with national, state, and jurisdictional/local regulations.

Signs containing general required notices, along with spaces for custom information, are commercially available and should be used. Warning signs containing the appropriate information and symbols are also commercially available and should be used.

3.15.1 MINIMUM REQUIRED SIGNAGE

At a minimum, sites which are not continuously supervised **shall** post the following:

- Authorized Personnel Only - No Trespassing

Mandatory legal requirements exist in which signage must be conspicuously posted to warn against unauthorized access to the site. Appropriate signage **shall** be posted during all phases of site planning, construction, and operation.
- Responsible Entity Identification
 - The site **shall** have conspicuous signage identifying the site operating entity and providing appropriate contact information.
 - Permit or licensing information (as assigned by the Federal Communications Commission or other equivalent) **shall** also be included.
- Battery Area Signage



NFPA signs advising the fire department of battery electrolyte reactivity with water shall be posted.

- Appropriate signage **shall** be present on doors leading to battery rooms and within the room itself, notifying personnel of explosion, chemical, and electrical hazards within the area.
- “NO SMOKING” signs **shall** be prominently displayed in the battery room and on the exterior of the battery room entry door. Smoking, and any other spark-producing materials or activities, **shall** be strictly prohibited in this area.

3.15.2 ADDITIONAL SIGNAGE

- Depending on the site's function, additional signage may be required. These signs typically notify of potential hazards associated with authorized or unauthorized site entry.
- Engineering personnel designing the site **shall** be aware of conditions that may be present at the site that could warrant warning signage. Such conditions are, but are not limited to, high voltage and RF energy emissions hazards.
- See Appendix A for additional information regarding EME signage.

EXTERNAL GROUNDING (EARTHING)

This chapter provides requirements and guidelines for designing and installing the external grounding (earthing) electrode system at a communications site.

This chapter provides information on the following topics:

- “Lightning Activity and Exposure” on page 4-3
- “Common Grounding (Earthing)” on page 4-5
- “Grounding (Earthing) Electrode System Component and Installation Requirements” on page 4-7
- “Dissimilar Metals and Corrosion Control” on page 4-34
- “Bonding to the External Grounding (Earthing) Electrode System” on page 4-40
- “Minimum Site Grounding (Earthing) Requirements” on page 4-44
- “Grounding (Earthing) Roof-Mounted Antenna Masts and Metal Support Structures” on page 4-74
- “Grounding (Earthing) Rooftop Mounted Tower Structures” on page 4-79
- “Special Grounding (Earthing) Applications” on page 4-81
- “Special Grounding (Earthing) Situations” on page 4-88

NOTE: Throughout this chapter the terms *grounding* and *earthing* are used synonymously.

4.1 INTRODUCTION

The requirements and guidelines in this chapter are derived from a compilation of local and national codes, widely accepted industry codes and standards, and good engineering practices. Such codes and standards are from, but not limited to, the following standards organizations:

- Alliance for Telecommunications Industry Solutions (ATIS)
- American National Standards Institute (ANSI)
- Australian Standards® (AS)
- British Standards Institution (BS)
- International Association of Electrical Inspectors (IAEI)
- International Electrotechnical Commission (IEC)
- Institute of Electrical and Electronics Engineers (IEEE)
- National Fire Protection Association (NFPA)
- Telecommunications Industry Association (TIA)
- Underwriters Laboratories (UL)
- United States Department of Defence (DoD)
- United States Federal Aviation Administration (FAA)
- United States National Weather Service

References to the specific industry codes and standards on which this chapter is based are provided throughout. The requirements and guidelines in this chapter are provided to enhance personnel safety and equipment reliability.

Safety of personnel and protection of sensitive electronic equipment from ground faults, lightning, ground potential rise, electrical surges, and power quality anomalies is of utmost importance at any communications site. Though unexpected electrical events like lightning strikes and power surges cannot be prevented, this chapter provides design and installation information on communications site grounding electrode systems that may help minimize damage caused by these events.

**CAUTION**

Grounding (earthing) and bonding alone are not enough to adequately protect a communications site. Transient voltage surge suppression (TVSS) techniques, using appropriate surge protection devices (SPD), shall be incorporated at a communications site in order to provide an adequate level of protection. See Chapter 7, “Surge Protective Devices,” for details and requirements.

A grounding electrode system **shall** have low electrical impedance, with conductors large enough to withstand high fault currents. The lower the grounding electrode system impedance, the more effectively the grounding electrode system can dissipate high-energy impulses into the earth.

**WARNING**

The AC power system ground shall be sized appropriately for the electrical service and shall be approved by the local authority having jurisdiction.

All site development and equipment installation work **shall** comply with all applicable codes in use by the authority having jurisdiction. Grounding systems **shall** be installed in a neat and workmanlike manner (NFPA 70-2005, Article 110.12 and NFPA 780-2004, section 1.4). Where conflicting, the more stringent standard should be followed. Government and local codes **shall** take precedence over the requirements of this manual.

Unusual site conditions may require additional effort to achieve an effectively bonded and grounded (earthed) site. See “Special Grounding (Earthing) Situations” on page 4-88 in these instances. Consultation with Motorola Engineering or an engineering firm specializing in grounding electrode system design is recommended.

Some of the benefits of a properly designed and installed low-impedance grounding electrode system are described below (See ANSI T1.333-2001, section 4; ANSI T1.334-2002, section 5.1; BS 7430:1998; IEC 60364-1; IEEE STD 142-1991, section 1.3; IEEE STD 1100-1999, section 3.3.1; and NFPA 70-2005, Article 250.4 for additional information):

- To help limit the voltage caused by accidental contact of the site AC supply conductors with conductors of higher voltage.
- To help dissipate electrical surges and faults, to minimize the chances of injury from grounding system potential differences.
- To help limit the voltages caused by lightning.
- To help maintain a low potential difference between exposed metallic objects.

- To stabilize the AC voltage relative to the earth under normal conditions.
- To contribute to reliable equipment operation.
- To provide a common signal reference ground.

4.2 LIGHTNING ACTIVITY AND EXPOSURE

Communications facilities **shall** be defined as exposed to lightning unless thunderstorm activity in the area is an average of five thunderstorm-days per year or fewer and soil resistivity at the site is less than 10,000 ohm-centimeters (Ω -cm). The soil resistivity **shall** be measured as described in ANSI/IEEE STD 81. (ANSI T1.313-2003, section 5.1.1) See Appendix B for soil resistivity measurement methods.

Figure 4-1 and Figure 4-2 are maps representing typical lightning activity throughout the world. These figures are for general informational and educational purposes only and are not indicative of current or future lightning activity. The average amount of lightning that occurs in any given area varies significantly from year to year.

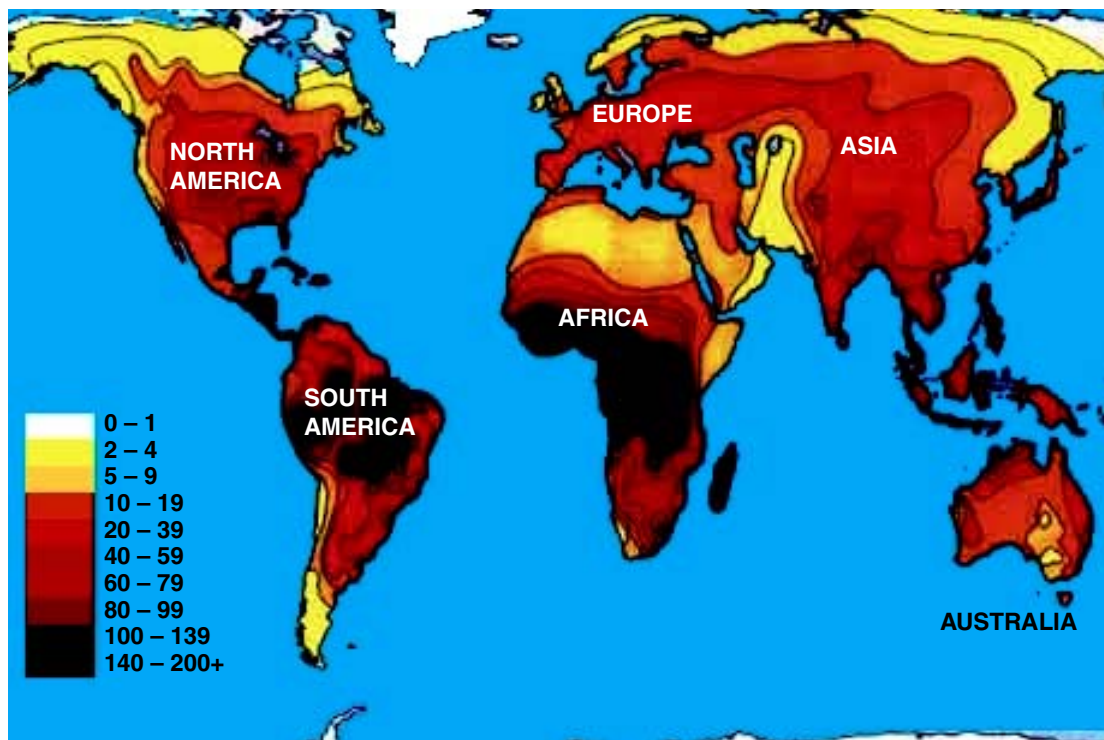

FIGURE 4-1 LIGHTNING ACTIVITY, THUNDERSTORM DAYS PER YEAR

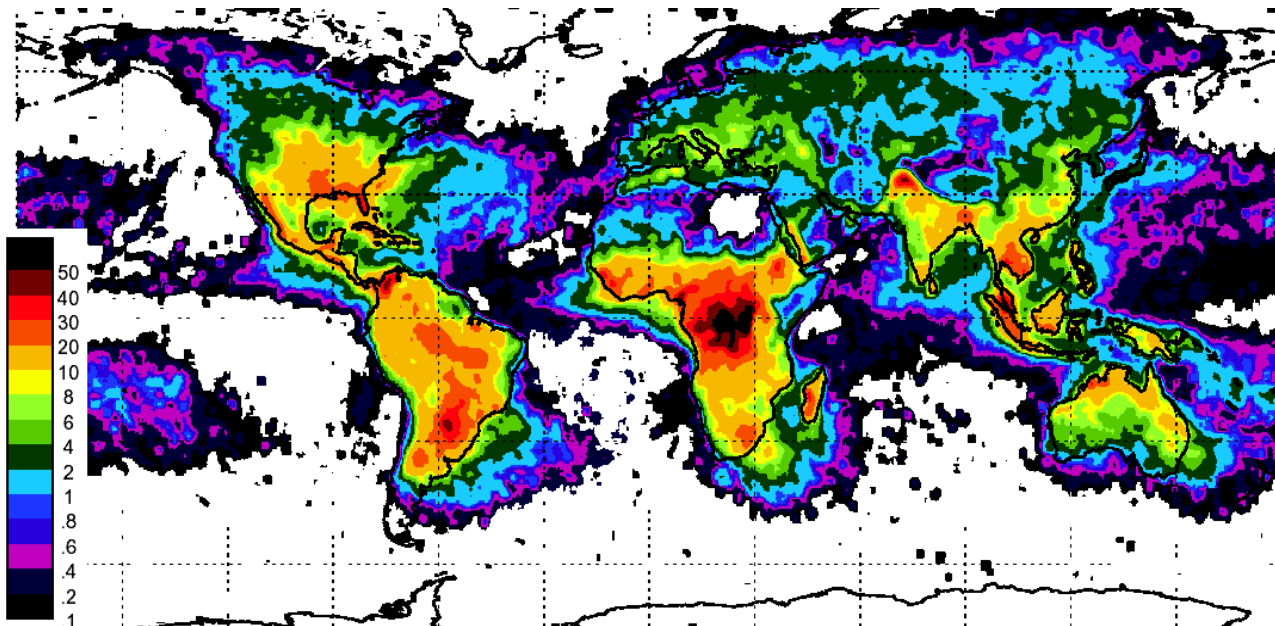

FIGURE 4-2 LIGHTNING ACTIVITY, FLASH DENSITY (FLASHES PER SQUARE KILOMETER PER YEAR)

Table 4-1 provides a relationship between thunderstorm days per year and lightning flashes per square kilometer per year (BS 6651:1999, table 6).

TABLE 4-1 RELATIONSHIP BETWEEN THUNDERSTORM DAYS PER YEAR AND LIGHTNING FLASHES PER SQUARE KILOMETER PER YEAR

Thunderstorm days per year	Flashes per square kilometer per year		Flashes per square mile per year	
	Mean	Limits	Mean	Limits
5	0.2	0.1 to 0.5	0.5	0.25 to 1.35
10	0.5	0.15 to 1	1.29	0.38 to 2.59
20	1.1	0.3 to 3	2.84	0.77 to 7.77
30	1.9	0.6 to 5	4.92	1.55 to 13
40	2.8	0.8 to 8	7.25	2 to 20.7
50	3.7	1.2 to 10	9.58	3.1 to 25.9
60	4.7	1.8 to 12	12.17	4.66 to 31
80	6.9	3 to 17	17.87	7.8 to 44
100	9.2	4 to 20	23.82	10.36 to 51.8

NOTE: Information obtained from BS 6651:1999, Table 6.

Communications facilities located at elevations significantly above the average elevation of the surrounding terrain (such as hilltops, fire towers, airport control towers, and high-rise buildings) **shall** be considered exposed to lightning regardless of thunderstorm activity and soil resistivity. (ANSI T1.313-2003, section 5.1.1.)

Communications facilities with a tower **shall** be considered as exposed, regardless of thunderstorm activity and soil resistivity. By their very construction, radio antennas/towers are considered exposed to the possible damaging effects of lightning. Tall structures, such as towers, buildings and antenna masts, provide a favorable discharge point for lightning strokes. (ANSI T1.313-2003, section 5.2.3.)

Some communications facilities may be classified as unexposed if the building and tower are within the zone of protection of a higher structure. Only a qualified engineer should determine if the communications facility is unexposed. The following standards can be used by the engineer to help determine if the communications facility is unexposed: BS 6651:1999, IEC 61024-1-2, NFPA 780-2004, or other applicable standard in effect and recognized by the local authority having jurisdiction.

4.3 COMMON GROUNDING (EARTHING)

At a communications site, there **shall** be only one grounding (earthing) electrode system. For example, the AC power system ground, communications tower ground, lightning protection system ground, telephone system ground, exposed structural building steel, underground metallic piping that enters the facility, and any other existing grounding electrode system **shall** be bonded together to form a single grounding electrode system (ANSI T1.313-2003; ANSI T1.333-2001; ANSI T1.334-2002; IEC 61024-1-2, section 2.4.4; IEEE STD 1100-1999; NFPA 70-2005, Articles 250.58, 250.104, 250.106, 800.100, 810.21, and 820.100; and NFPA 780-2004, Section 4.14).

All grounding media in or on a structure **shall** be interconnected to provide a common ground potential. This **shall** include, but is not limited to, the AC power system ground, communications tower ground, lightning protection system ground, telephone system ground, exposed structural building steel, and underground metallic piping systems. Underground metallic piping systems typically include water service, well castings located within 7.6 m (25 ft.) of the structure, gas piping, underground conduits, underground liquefied petroleum gas piping systems, and so on. Interconnection to a gas line **shall** be made on the customer's side of the meter (NFPA 780-2004, Section 4.14.1.3).

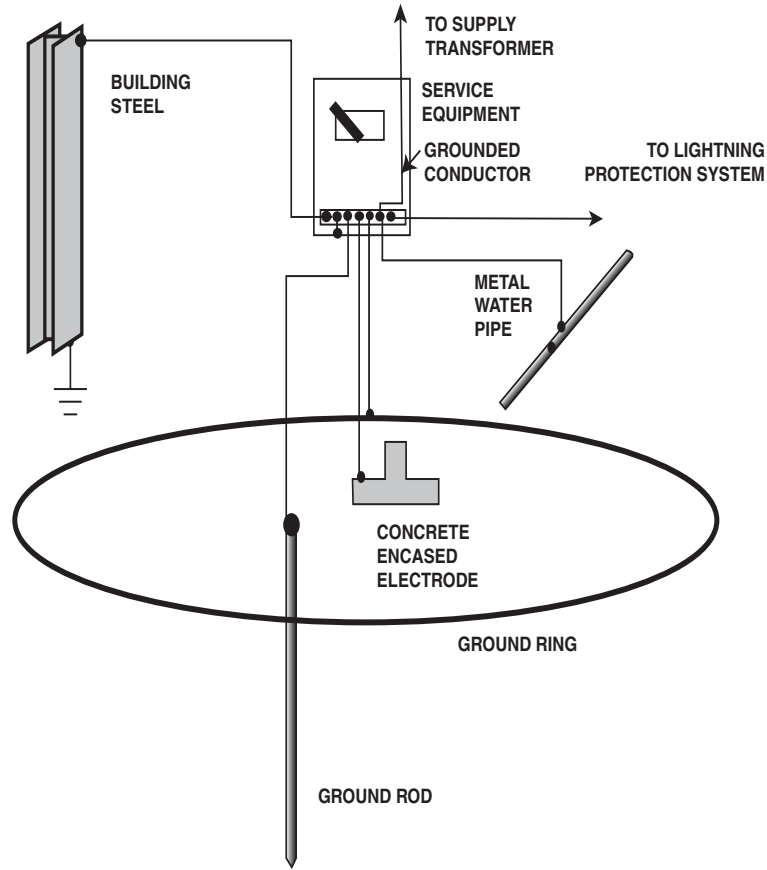

FIGURE 4-3 COMMON GROUNDING EXAMPLE

4.4 GROUNDING (EARTHING) ELECTRODE SYSTEM COMPONENT AND INSTALLATION REQUIREMENTS



WARNING

To prevent accidental damage to underground utilities, always have the local utility company or utility locator service locate the underground utilities before excavating or digging at a site.

The external grounding (earthing) electrode system may consist of, but is not limited to, the following components, shown in Figure 4-4:

- Ground rods or other grounding electrodes
- Concrete encased electrode
- Building or shelter ground ring
- Tower ground ring
- Grounding conductors
- Radial grounding conductors
- Guy wire grounding conductors (guyed towers only)
- Tower ground bus bar
- External ground bus bar
- Fence grounding conductors

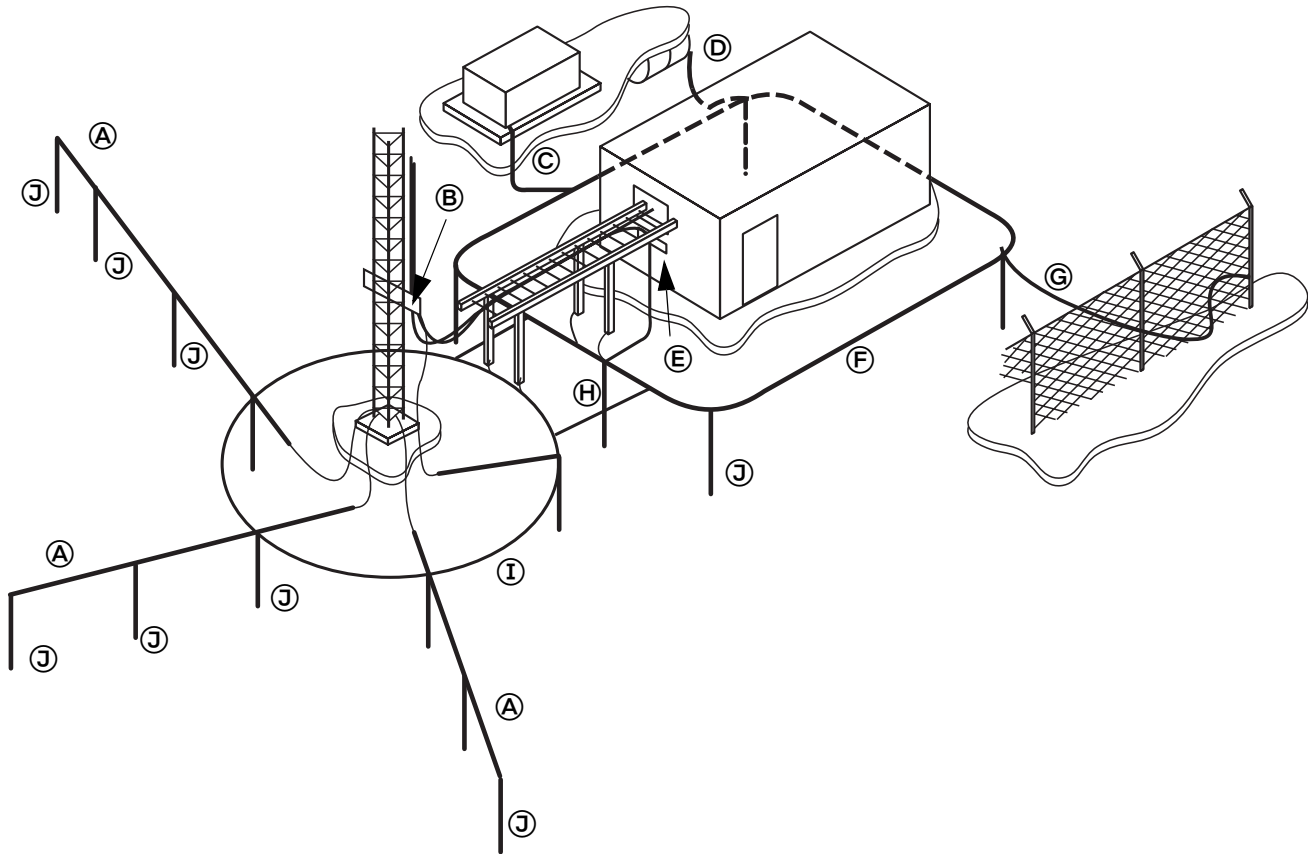

- A: Grounding Radials**
- B. Tower Ground Bus Bar and Down Conductor**
- C. Generator Grounding Conductor**
- D. Buried Fuel Tank Grounding Conductor**
- E. External Ground Bus Bar**
- F. Shelter Ground Ring**
- G. Fence Grounding Conductor**
- H. Ground Ring Bonding Conductors (2 minimum)**
- I. Tower Ground Ring**
- J. Earthing Electrodes (Ground Rods)**

FIGURE 4-4 TYPICAL EXTERNAL GROUNDING ELECTRODE SYSTEM

4.4.1 GROUNDING (EARTHING) ELECTRODES

Grounding (earthing) electrodes are the conducting elements used to connect electrical systems and/or equipment to the earth. The grounding electrodes are placed into the earth to maintain electrical equipment at the potential of the earth. Grounding electrodes may be ground rods, metal plates, concrete encased electrodes, ground rings, electrolytic ground rods, the metal frame of building or structure, and metal underground water pipes (NFPA 70-2005, Article 250 (III)).

NOTE: Metallic underground gas piping **shall not** be used as a grounding electrode (NFPA 70-2005, Article 250.52), but **shall** be bonded upstream from the equipment shutoff valve to the grounding electrode system as required by NFPA 70-2005, Article 250.104 and NFPA 780-2004, section 4.14.1.3.

4.4.1.1 GROUNDING (EARTHING) ELECTRODE RESISTANCE CHARACTERISTICS AND SPHERE OF INFLUENCE

Around a grounding (earthing) electrode, such as a driven ground rod, the resistance of the soil is the sum of the series resistances of virtual concentric shells of earth, located progressively outward from the rod. The shell nearest the ground rod has the smallest circumferential area, or cross section, so it has the highest resistance. Successive outward shells have progressively larger areas, therefore, progressively lower resistances. (IEEE STD 142-1991, section 4.11 and MIL-HDBK-419A).

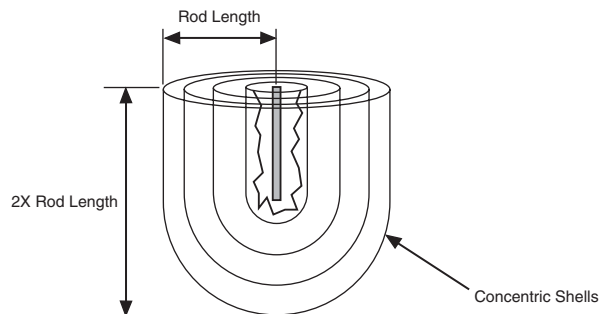

FIGURE 4-5 GROUNDING ELECTRODE SPHERE OF INFLUENCE

The effect of the concentric shells is that it takes a finite amount of earth for a ground rod to fully realize its resistance value. This finite amount of earth is commonly known as the ground rod's sphere of influence. The sphere of influence for a ground rod is commonly thought of to be a radius around the ground rod equal to its length; the ground rod achieves approximately 94% of its resistance value at this radius (100% is achieved at approximately 2.5 times the rod length) (IEEE STD 142-1991, section 4.1). See Figure 4-5.

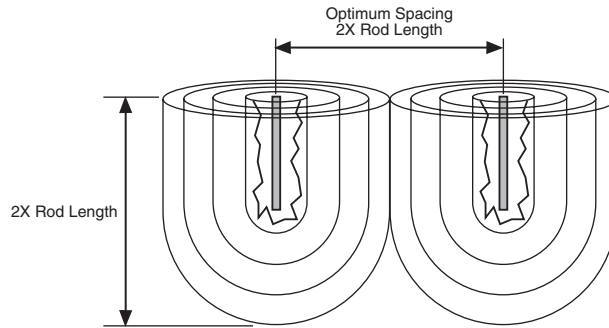

FIGURE 4-6 MINIMUM GROUNDING ELECTRODE SPACING FOR MAXIMUM EFFECTIVITY

Table 4-2 provides the relationship between percentage of total ground rod resistance and the radial distance from the ground rod (IEEE STD 142-1991, Table 9).

TABLE 4-2 TOTAL GROUND ROD RESISTANCE VS. DISTANCE FROM GROUND ROD

Distance from Electrode Surface (r)**		Approximate Percentage of Total Resistance
ft	Meters	
0.1	0.03	25%
0.2	0.06	38%
0.3	0.09	46%
0.5	0.15	52%
1.0	0.3	68%
5.0	1.5	86%
10.0*	3.0*	94%
15.0	4.6	97%
20.0	6.1	99%
25.0	7.6	100%

* 94% of the resistance to remote earth occurs within a radius equal to the length of the ground rod. This radius is commonly used as the ground rod's sphere of influence.

** Ground rod resistance at a radius (r) from a 3 m × 16 mm (10 ft. × 0.625 in.) ground rod (From IEEE STD 142-1991, Table 9)

The following observations can be made from the above table (IEEE STD 142-1991, chapter 4):

- Within the first 2.5 cm (1 in.) from the ground rod, 25% of the total resistance to earth is achieved.

- Within the first 152 mm (6 in.) from the ground rod, 52% of the total resistance to earth is achieved.
- The area immediately around a ground rod is the most important for reducing its resistance to earth. See “Grounding (Earthing) Electrode Encasement Materials” on page 4-27 for information on reducing resistance.
 - In high resistivity soil areas, decreasing the soil resistance in this area is useful in improving the effectiveness of the grounding electrode system.
 - In porous soil areas, decreasing the contact resistance with the ground rod in this area is useful in improving the effectiveness of the grounding electrode system.

Unless specified elsewhere in this chapter, ground rods should be installed apart from one another by the sum of their respective lengths, so their spheres of influence do not overlap (See Figure 4-6). This is especially important when only a small number of ground rods are installed, such as around tower ground rings.

NOTE: In a given area, more ground rods installed closer together (such as one length apart from one another) will achieve a lower resistance to earth than fewer rods installed further apart (such as twice the length apart from one another). For example, five 3 m (10 ft.) ground rods installed 6.1 m (20 ft.) apart in an 24.4 m (80 ft.) straight line will achieve a resistance to earth of 7.8 ohms (assuming 10,000 ohm-cm soil). Nine 3 m (10 ft.) ground rods installed 3 m (10 ft.) apart in the same 24.4 m (80 ft.) straight line will achieve a resistance to earth of 5.7 ohms.

4.4.1.2 GROUND RODS

Typical ground rods are shown in Figure 4-7. Requirements for ground rods are listed below. See IEEE STD 142-1991, section 4.3.1 and UL 467-2004 for additional information.

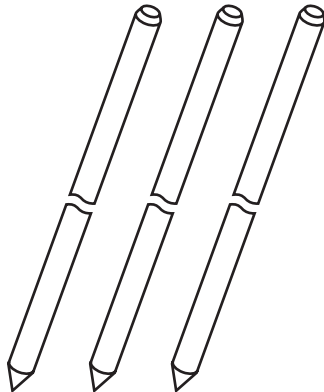

FIGURE 4-7 TYPICAL GROUND RODS

4.4.1.2.1 GROUND ROD SPECIFICATIONS

- Ground rods **shall** be UL listed (or equivalent).
- Ground rods **shall** be constructed of copper-clad steel, solid copper, hot-dipped galvanized steel, or stainless steel (ANSI-J-STD-607-A-2002, section C.4.3, and ANSI T1.334-2002, section 5.3.2). See NFPA 70-2005, Article 250.52 and UL 467-2004, section 9.2.1 for additional information.

NOTE: Stainless steel ground rods **shall** be formed of an austenitic stainless steel of the 18 percent chromium, 8 percent nickel type (UL 467-2004, section 9.2.6).

- Ground rods **shall** have a minimum length of 2.4 m (8 ft.) (ANSI T1.313-2003, section 10.3.1, ANSI T1.334-2002, section 5.3.2, NFPA 70-2005, Article 250.52, and UL 467-2004). For areas highly prone to lightning, and/or military installations, longer rods, such as 3 m (10 ft.), should be considered for the minimum length (MIL-HDBK-419A and MIL-STD-188-124B).
- Ground rods **shall** have a minimum diameter of 15.9 mm (0.625 in.) (ANSI T1.313-2003, section 10.3.1 and ANSI T1.334-2002, section 5.3.2), unless otherwise allowed by the UL listing of the ground rod (UL 467). See NFPA 70-2005, Article 250.52 for additional information.
- Ground rods **shall** be free of paint or other nonconductive coatings (NFPA 70-2005, Article 250.53 and NFPA 780-2004, section 4.13.2).

4.4.1.2.2 GROUND ROD INSTALLATION

- Where practical, ground rods **shall** be buried below permanent moisture level (MIL-HDBK-419A and NFPA 70-2005, Article 250.53).
- Where practical, ground rods **shall** penetrate below the frost line (MIL-HDBK-419A).
- Ground rods longer than the minimum required 2.4 m (8 ft.) may be required to maintain contact with permanently moist, unfrozen soil (MIL-HDBK-419A).
- When part of a ground ring system, the upper end of the ground rods **shall** be buried to the depth of the ground ring, typically 762 mm (30 in.) minimum below finished grade. The upper end of the ground rods should be buried to the same depth as the ground ring to allow for easy bonding to the ground ring. (See “External Building and Tower Ground Ring” on page 4-22.)
- When not part of a ground ring system, such as in a Type A site, the entire length of the rod **shall** be in contact with soil (NFPA 70-2005, Article 250.53). It is recommended to install the ground rods so the upper end of the rod is buried to a minimum depth of 610 mm (24 in.) below the surface of the earth (NFPA 780-2004, section 4.13.2.3). See Figure 4-8 for typical single ground rod installations.

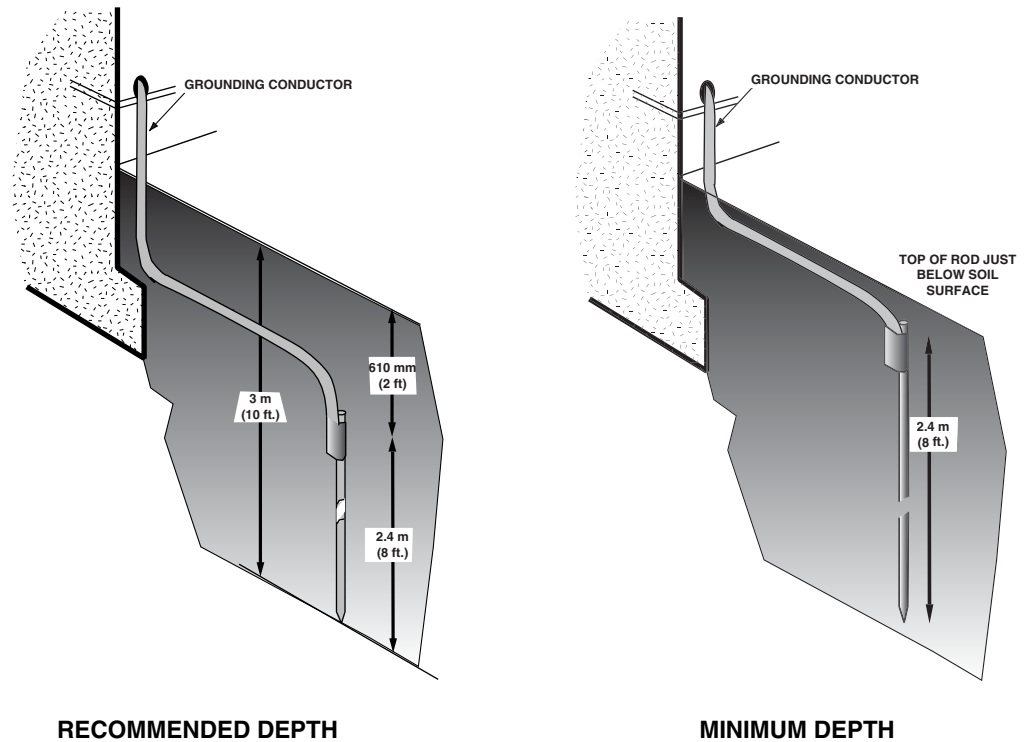

FIGURE 4-8 TYPICAL SINGLE GROUND ROD INSTALLATION

- Ground rods **shall not** be installed closer than 1.8 m (6 ft.) from other ground rods and grounding electrodes (NFPA 70-2005, Article 250.56). See Figure 4-31 on page 4-49 for an example.
- Unless otherwise stated in this chapter, ground rods **shall not** be installed closer to one another than the sum of their respective lengths, when possible. This is especially important for the ground rods associated with tower ground rings. See “Grounding (Earthing) Electrode Resistance Characteristics and Sphere of Influence” on page 4-9
- See “External Building and Tower Ground Ring” on page 4-22 for ground rod installation requirements on ground rings.
- The method of bonding grounding conductors to ground rods **shall** be compatible with the types of metals being bonded (See “Dissimilar Metals and Corrosion Control” on page 4-34).
- Ground rods that cannot be driven straight down, due to contact with rock formations, may be driven at an oblique angle of not greater than 45 degrees from the vertical, or may be buried horizontally and perpendicular to the building, in a trench at least 762 mm (30 in.) deep, as shown in Figure 4-9 (NFPA 70-2005, Article 250.53).

IMPORTANT: The top of a ground rod **shall not** be cut off if contact with rocks prevents driving of the rod. Alternate driving techniques, as describe above, **shall** be used in these cases.

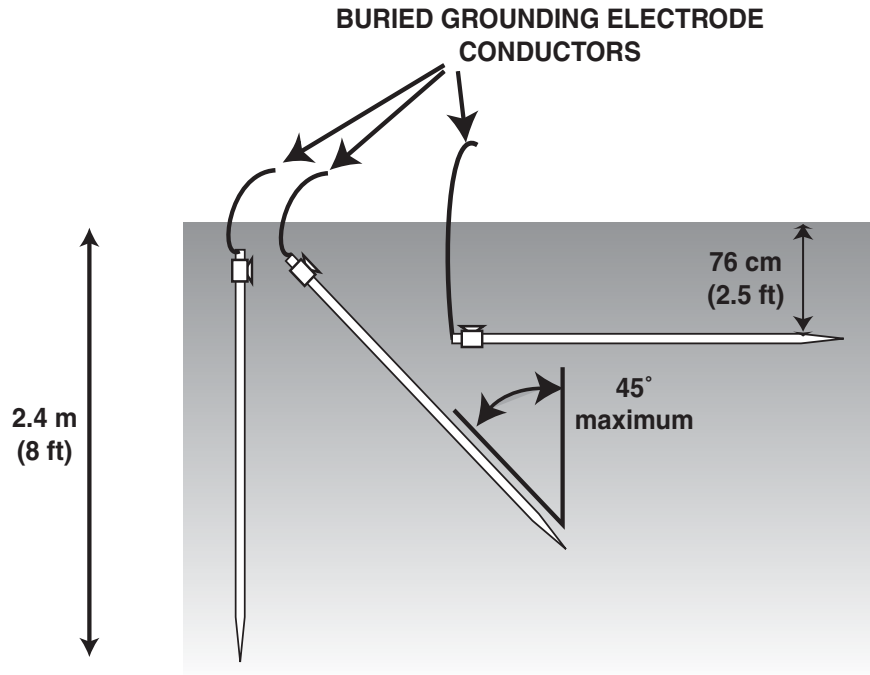

FIGURE 4-9 ANGLED GROUND ROD INSTALLATION



WARNING

When operating any kind of power tool, always wear appropriate safety glasses and other protective gear to prevent injury.

- Hammer drills or electric jackhammers may be used to drive in the ground rods. Do not deform the head of the ground rod. See IEEE STD 142-1991, section 4.3.2. for additional information.
- If rock formations prevent ground rods from being driven to the specified depth, an alternate method of achieving an acceptable grounding electrode system **shall** be engineered and implemented. See “Special Grounding (Earthing) Situations” on page 4-88 for additional information.
- When the grounding electrode system design requires deeper ground rods (in order to lower the grounding electrode system resistance, penetrate down to permanent moisture level, or to penetrate below the frost line) two or more ground rods may be joined together by use of a coupling (threaded, compression sleeve, or exothermic weld). Threaded rods or compression sleeves **shall** be UL listed. (IEEE STD 142-1991, section 4.3.1). See Figure 4-10 for an example of splicing ground rods together.



FIGURE 4-10 SPLICING TWO GROUND RODS

4.4.1.2.3 EFFECT OF GROUND ROD SIZE ON RESISTANCE TO EARTH

Increasing the diameter of a ground rod does not significantly reduce its resistance to earth. Doubling the diameter of a rod reduces its resistance to earth by approximately 10%. See Figure 4-11.

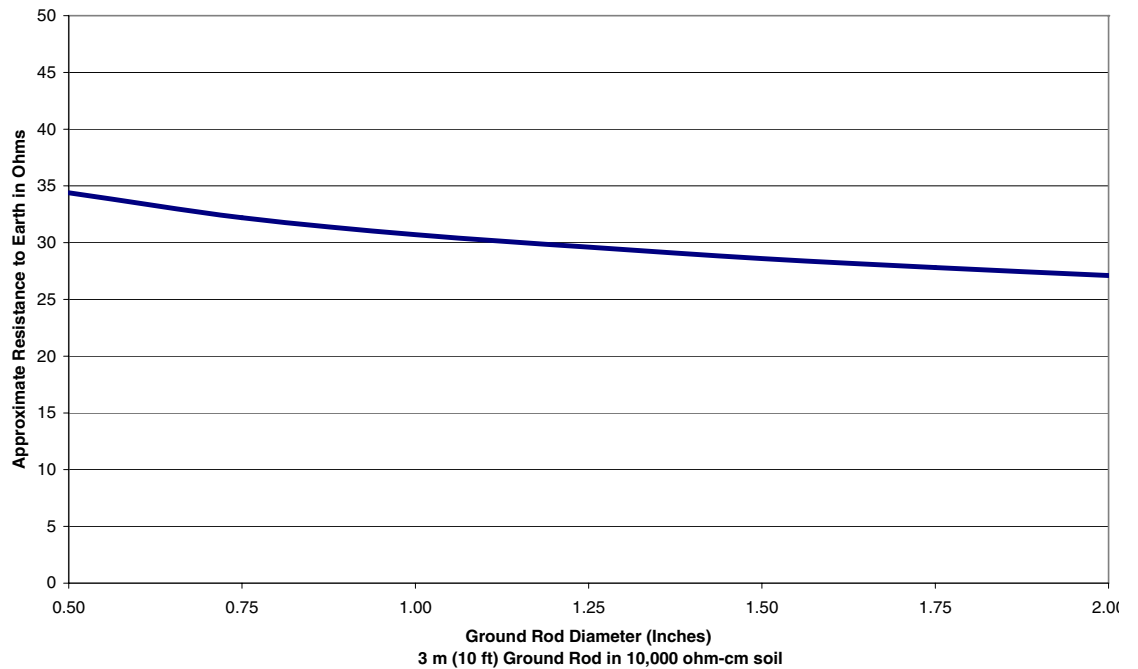

FIGURE 4-11 RESISTANCE TO EARTH DUE TO GROUND ROD DIAMETER

As the length of a ground rod is increased, its resistance to earth is substantially reduced. In general, doubling the length of a ground rod reduces the resistance to earth by 40%. See Figure 4-12.

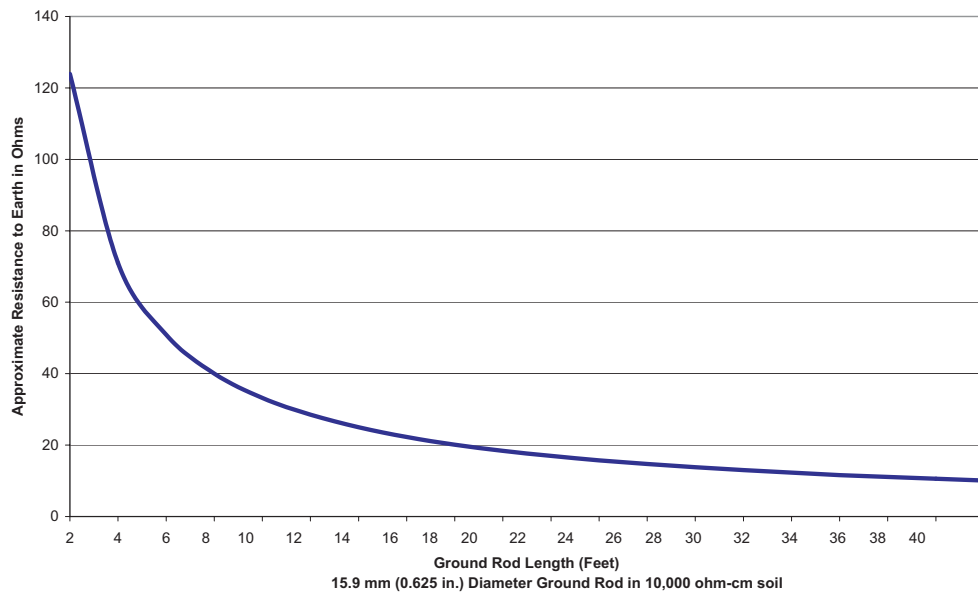

FIGURE 4-12 RESISTANCE TO EARTH DUE TO GROUND ROD LENGTH

4.4.1.2.4 EFFECT OF PARALLEL GROUND RODS

Figure 4-13 below shows the effects of adding additional ground rods (15.9 mm (0.625 in.) diameter by 3 m (10 ft.) long) together in parallel. As seen in the figure, the addition of one ground rod to the first ground rod (for a total of two rods) significantly reduces the resistance to earth of the ground rod system. Each subsequent ground rod added in parallel has less of an effect on the resistance to earth of the ground rod system.

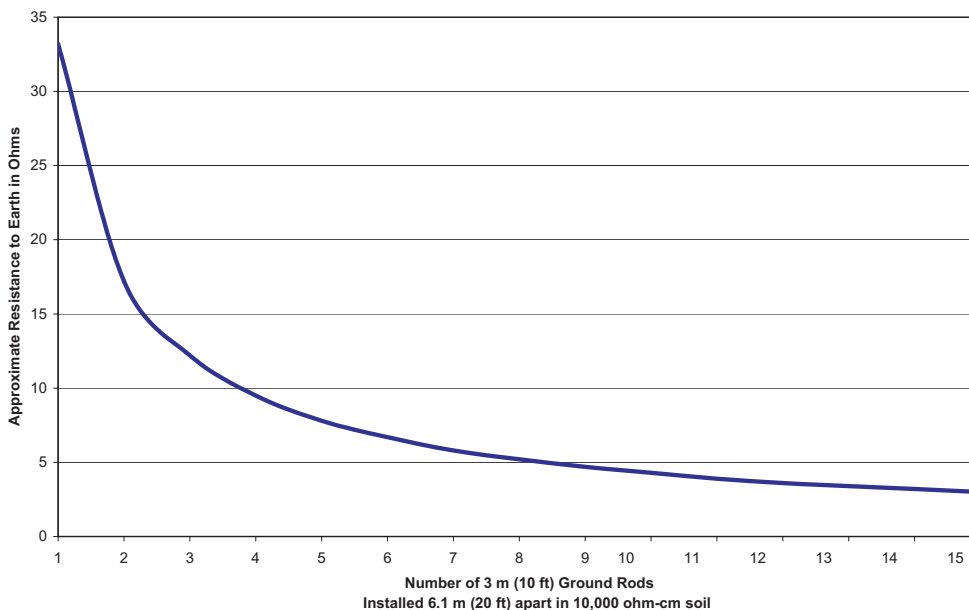

FIGURE 4-13 RESISTANCE TO EARTH DUE TO PARALLEL GROUND RODS

4.4.1.3 ELECTROLYTIC GROUND RODS

At sites where, due to poor soil conductivity (high resistivity) and/or limited space, an acceptable grounding (earthing) electrode system resistance cannot be achieved using standard ground rods, commercially available electrolytic ground rods should be considered. See MIL-HDBK-419A Volume I, section 2.9.5, and UL 467-2004, section 9.2.7 for additional information. Electrolytic ground rods (Figure 4-14) are available in straight or L-shaped versions and in various lengths from 3 m (10 ft.) to 6.1 m (20 ft.), or longer as a special order. Electrolytic ground rods are generally constructed of 54 mm (2.125 in.) diameter hollow copper pipe. This copper pipe is filled with a mixture of non-hazardous natural earth salts. Holes at various locations on the pipe allow moisture to be hygroscopically extracted from the air into the salt within the pipe, therefore forming conductive electrolytes. These electrolytes then leach out of the pipe into the soil, improving soil conductivity. Electrolytic ground rods are inserted into a pre-drilled hole, or in the case of L-shaped rods, placed into a trench at least 762 mm (30 in.) deep, and encased in a grounding electrode encasement material. See “Grounding (Earthing) Electrode Encasement Materials” on page 4-27.

Electrolytic ground rods should be considered for use in grounding electrode systems covered by concrete or pavement, such as parking lots. By allowing moisture to enter, the design of the electrolytic ground rod improves the resistance of the grounding electrode system.

NOTE: Unless prohibited by local environmental authorities, condensation from the site's HVAC system may be routed to the ground rod area to keep the soil moist, improving conductivity.

Electrolytic ground rods may provide significant improvement over standard ground rods of the same length and may last several years longer than standard ground rods. The resistance to earth of electrolytic ground rods is generally more stable in environments with variations in temperature and moisture.

Requirements for the use of electrolytic ground rods are listed below:

- Electrolytic rods **shall** be UL listed (or equivalent).
- Electrolytic rods **shall** be installed per the manufacturers' recommendation.
- Electrolytic rods **shall** be free of paint or other nonconductive coatings (NFPA 70-2005, Article 250.53 and NFPA 780-2004, section 4.13.2.2).
- Electrolytes within the rod **shall** be environmentally safe and approved by the environmental authority having jurisdiction.
- L-shaped electrolytic rods **shall** be installed perpendicular to the building or shelter.
- L-shaped electrolytic rods (horizontal portion) **shall** be installed at least 762 mm (30 in.) below the earth's surface.
- Grounding electrode encasement materials (also known as backfill) **shall** be environmentally safe and approved by the environmental authority having jurisdiction. See “Grounding (Earthing) Electrode Encasement Materials” on page 4-27.
- Electrolytic rods should be maintenance free.

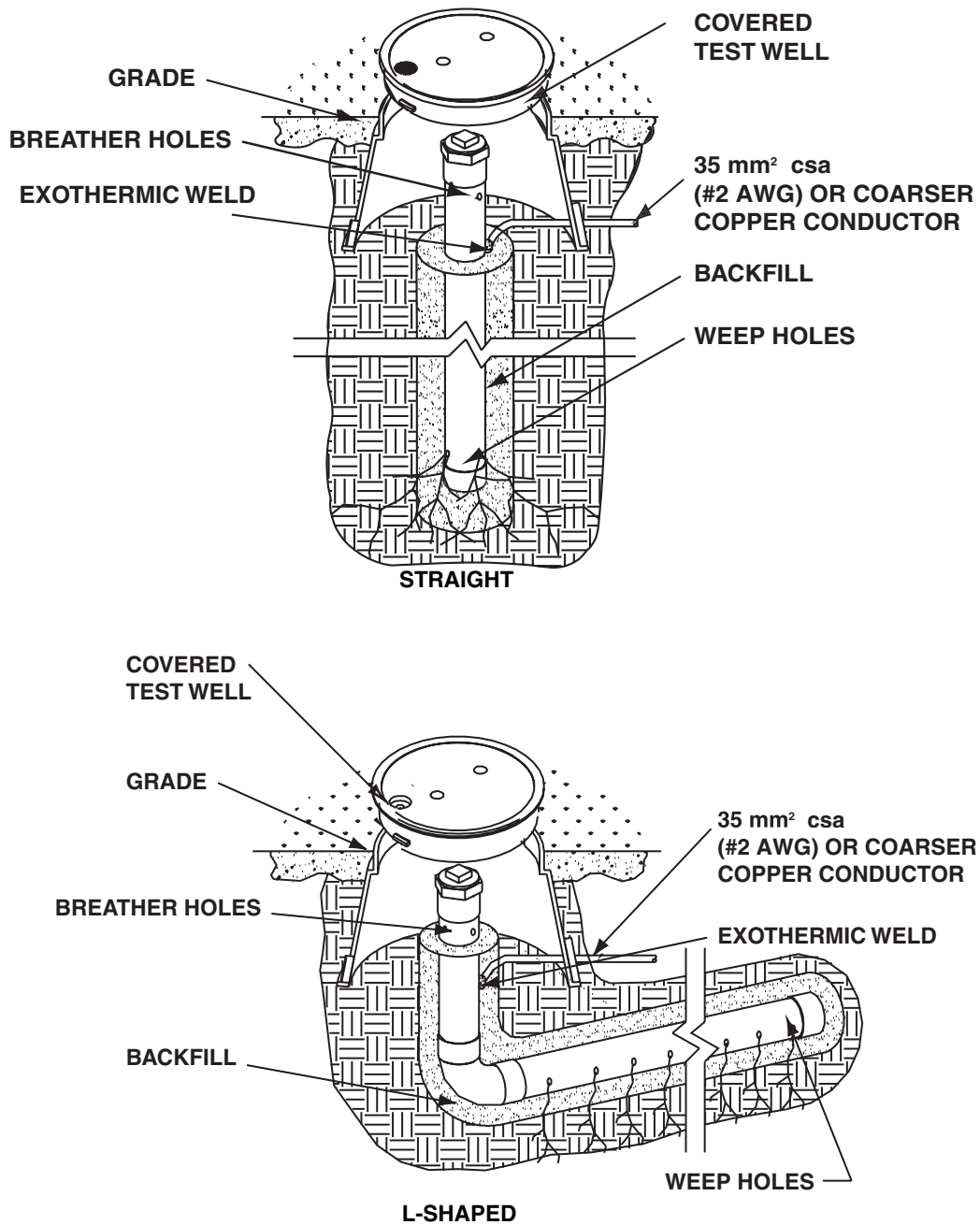
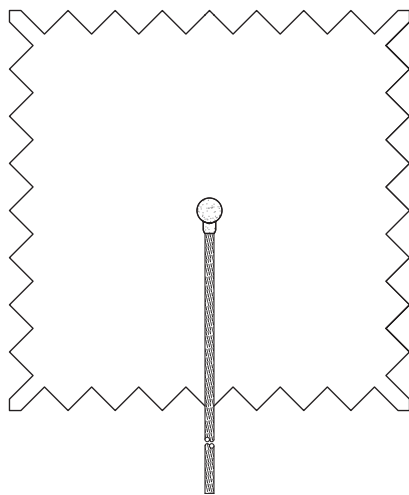

FIGURE 4-14 ELECTROLYTIC GROUND RODS

4.4.1.4 GROUND PLATE ELECTRODES

Ground plates (Figure 4-15) may be used in special cases, or if specifically engineered into the design of the grounding (earthing) electrode system. Requirements for the use of ground plate electrodes are listed below:

- Ground plates should only be used if soil conditions prohibit the use of standard ground rods, or if specifically engineered into the grounding electrode system.
- Ground plates should be UL listed (or equivalent).
- Ground plates **shall** be constructed of copper or copper-clad steel.
- Ground plates **shall** expose not less than 0.37 m² (2 ft.²) of surface to exterior soil (MIL-HDBK-419A, section 2.5.5; NFPA 70-2005, Article 250.52; and NFPA 780-2004, section 4.13.6.1).
- Ground plates **shall** have a minimum thickness of 1.5 mm (0.06 in.) (MIL-HDBK-419A, section 2.5.5 and NFPA 70-2005, Article 250.52).
- Ground plates **shall** be free of paint or other nonconductive coatings (NFPA 70-2005, Article 250.53 and NFPA 780-2004, section 4.13.2.2).
- Ground plates **shall** be buried not less than 762 mm (30 in.) below the surface of the earth (NFPA 70-2005, Article 250.53). If soil conditions do not allow the ground plate to be buried at this depth, see “Shallow Topsoil Environments” on page 4-97 for additional information.
- Where practical, a ground plate **shall** be embedded below permanent moisture level (BS 7430:1998, clause 10 and NFPA 70-2005, Article 250.53).
- Ground plates should be installed vertically to allow for minimum excavation and better contact with the soil when backfilling (BS 7430:1998, clause 10 and IEEE STD 142-1991, section 4.2.4). See Figure 4-16.



SERRATED EDGES PROVIDE MORE
EDGE SURFACE

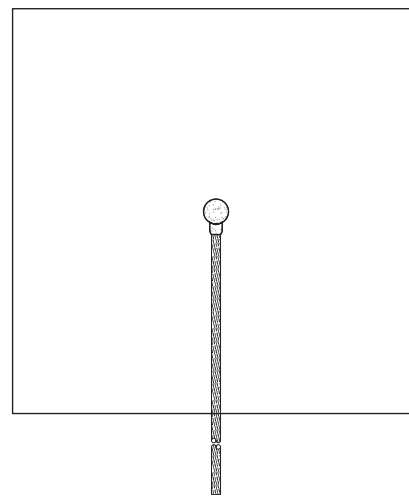

STRAIGHT EDGES

FIGURE 4-15 TYPICAL GROUND PLATES

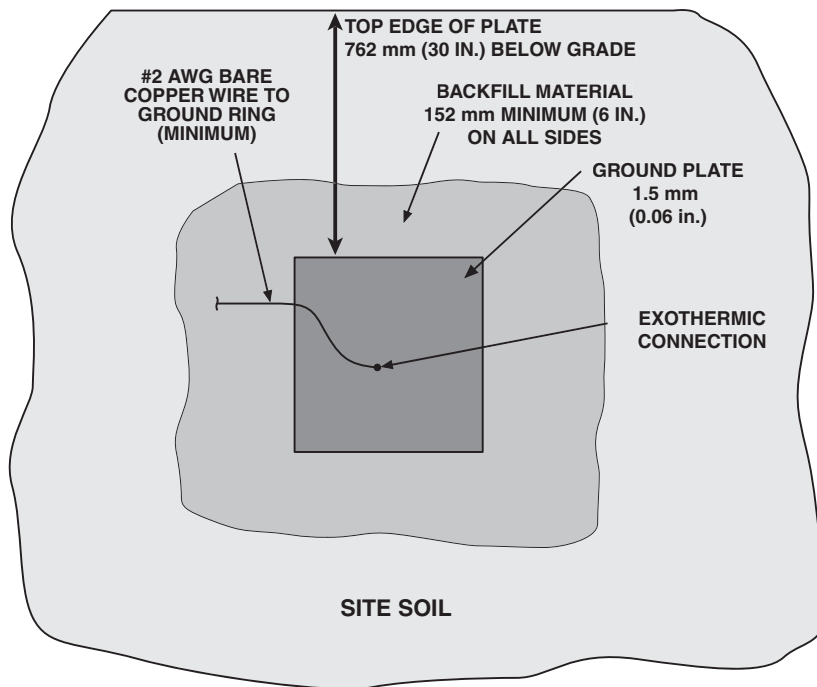

FIGURE 4-16 TYPICAL GROUND PLATE INSTALLATION

- A grounding electrode encasement material should be used to backfill around the ground plate to help insure effective contact with the earth (BS 7430:1998, clause 10). See “Grounding (Earthing) Electrode Encasement Materials” on page 4-27.

4.4.1.5 CONCRETE-ENCASED ELECTRODES

Though concrete-encased electrodes (also known as Ufer electrodes, named after Herbert G. Ufer, or foundation earth electrodes) are not required by this standard, they should be used in new construction as a method of supplementing the grounding (earthing) electrode system (IEC 61024-1-2, section 3.3.5). Concrete-encased electrodes (Figure 4-17) enhance the effectiveness of the grounding electrode system in two ways: the concrete absorbs and retains moisture from the surrounding soil, and the concrete provides a much larger surface area in direct contact with the surrounding soil. This is especially helpful at sites with high soil resistivity and/or limited area for installing a grounding electrode system. See IEEE STD 142-1991 section 4.2.3, and the International Association of Electrical Inspectors publication, *Soares Book on Grounding and Bonding*, 9th Edition, Appendix A for additional information. Requirements for a concrete-encased electrode, if used, are listed below (IEC 61024-1-2; NFPA 70-2005, Article 250.52; and NFPA 780-2004, section 4.13.3).

- Concrete-encased electrodes **shall** be encased by at least 51 mm (2 in.) of concrete, located within and near the bottom of a concrete foundation or footing that is in direct contact with the earth.
- Concrete-encased electrodes **shall** be at least 6.1 m (20 ft.) of bare copper conductor not smaller than 25 mm² csa (#4 AWG) or at least 6.1 m (20 ft.) of one or more bare or zinc galvanized or other conductive coated steel reinforcing bars or rods at least 12.7 mm (0.5 in.) in diameter.
- Concrete-encased electrodes **shall** be bonded to any other grounding electrode system at the site. See “Common Grounding (Earthing)” on page 4-5.

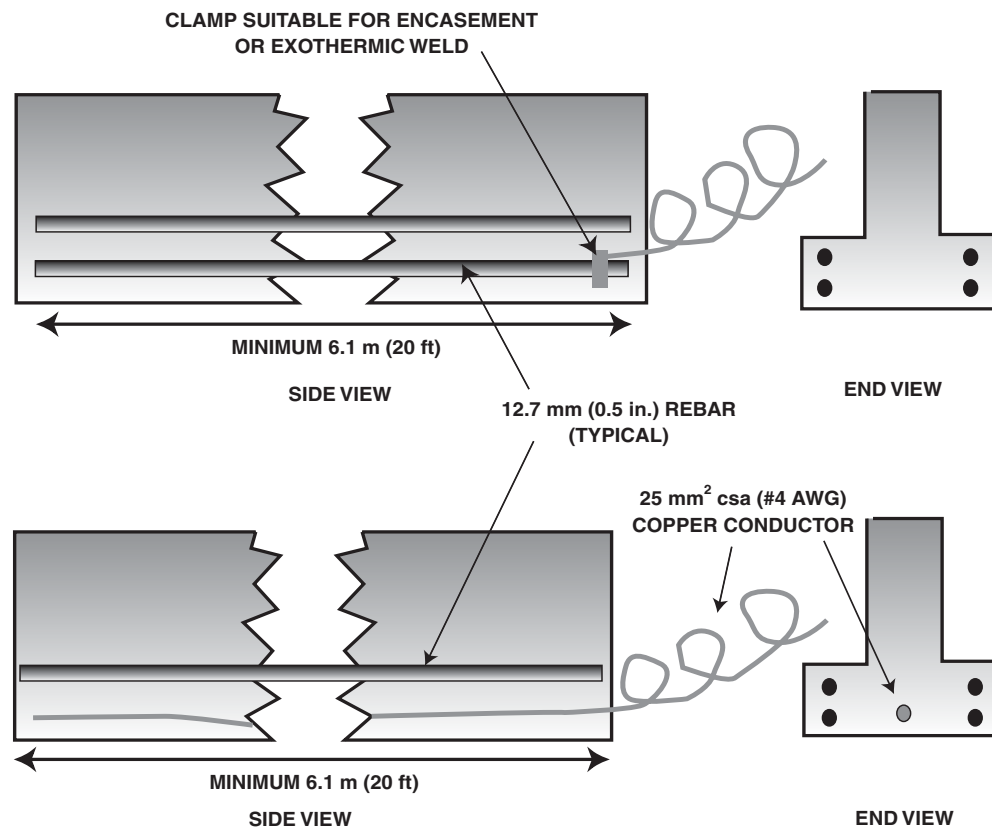
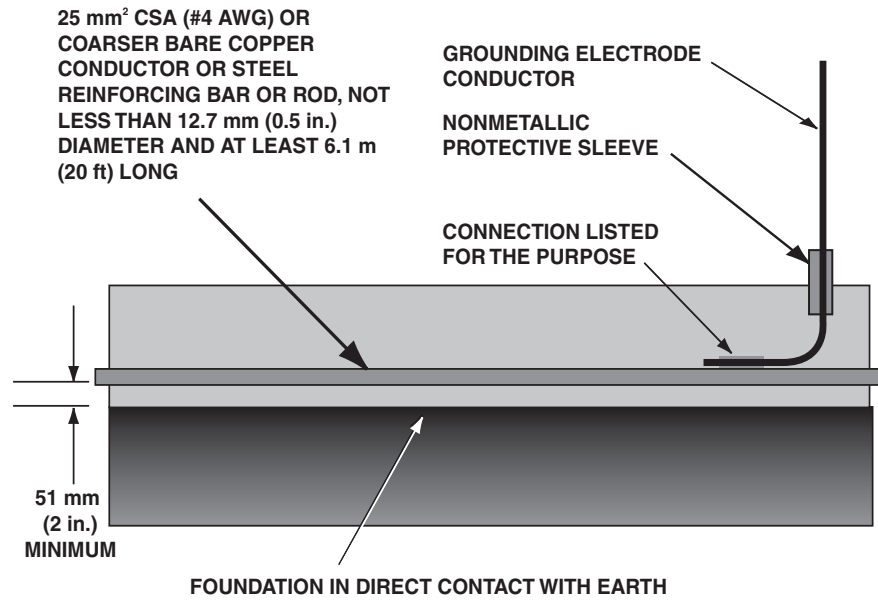

FIGURE 4-17 TYPICAL CONCRETE-ENCASED ELECTRODES

4.4.1.6 EXTERNAL BUILDING AND TOWER GROUND RING

The buried external ground rings (building and tower) provide a means of bonding ground rods together and bonding other grounding (earthing) electrode system components together, improving the overall grounding electrode system. The ground rings also help to equalize potential in the earth surrounding the tower and building structures, regardless of earth resistivity, by insuring that a low impedance current path exists throughout the area (ANSI T1.334-2002, section 5.3).

Requirement for external ground rings are listed below (see Figure 4-18):

- Unless otherwise stated, ground ring conductors **shall** be 35 mm² csa (#2 AWG) or coarser, bare, solid, tinned or un-tinned, copper (ANSI T1.313-2003 and ANSI T1.334-2002, section 5.3.1). See “Grounding (Earthing) Conductors” on page 4-28 for grounding conductor specifications.
- Solid, bare, tinned, copper conductor should be used to minimize galvanic corrosion between tower legs and other parts of the grounding electrode system (ANSI T1.313-2003, section 10.7).
- For areas highly prone to lightning, and/or military installations, larger conductors, such as 50 mm² csa (#1/0 AWG) or coarser, should be considered (MIL-HDBK-419A and MIL-STD-188-124B); stranded conductors may be used in this application.
- Building ground rings **shall** encircle the building or shelter whenever possible (ANSI T1.313-2003, ANSI T1.334-2002, MIL-HDBK-419A, and MIL-STD-188-124B).
- Tower ground rings **shall** encircle the tower structure whenever possible (ANSI T1.334-2002, section 5.3 and MIL-HDBK-419A).
- The ends of the conductor **shall** be joined together to form a ring using an exothermic weld or listed irreversible high-compression connector (ANSI T1.334-2002, section 5.3.1 and MIL-STD-188-124B). This may be easily completed at a ground rod.
- Building ground rings and tower ground rings **shall** be bonded together in at least two points using a 35 mm² csa (#2 AWG) or coarser, bare, solid, tinned or un-tinned, copper conductor (ANSI-J-STD-607-A-2002, section C.4.7, ANSI T1.334-2002, figure 1, and MIL-STD-188-124B). The conductors should be physically separated as much as practical. See “Common Grounding (Earthing)” on page 4-5.

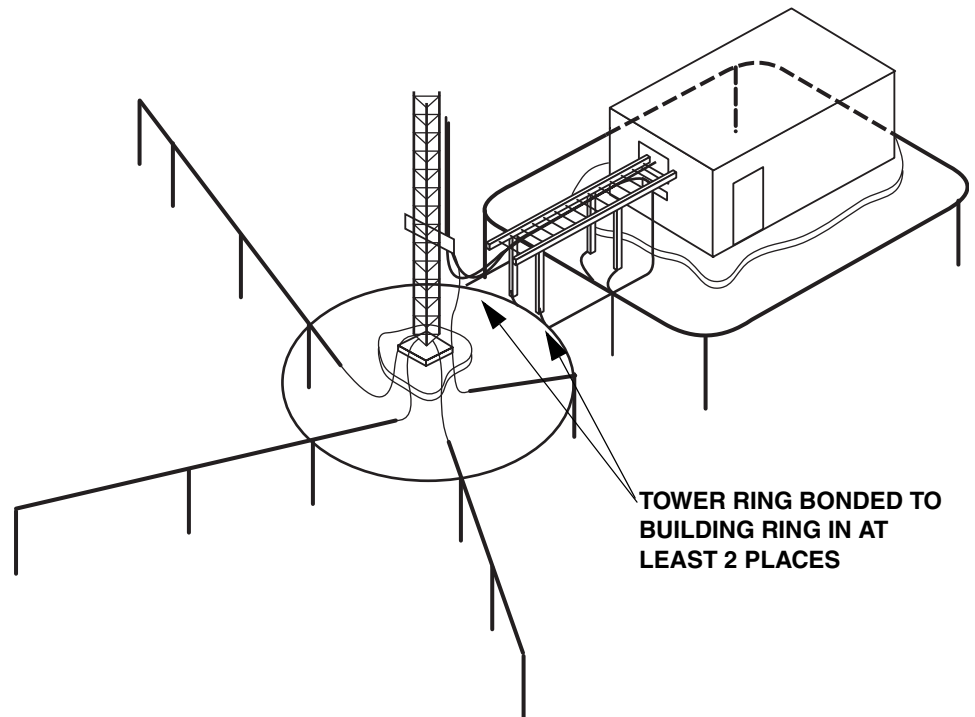

FIGURE 4-18 BONDING BUILDING AND TOWER GROUND RING SYSTEMS

- Ground rings **shall** be installed in direct contact with the earth at a depth of 762 mm (30 in.) below the earth's surface whenever possible, or below the frost line, whichever is deeper (ANSI T1.334-2002, section 5.3.1 and NFPA 70-2005, Article 250.53).
- Building ground rings **shall** be installed at least 914 mm (3 ft.) from the building foundation and should be installed beyond the drip line of the roof. It is recommended that the building ground ring and ground rods be positioned 610 mm to 1.8 m (2 ft. to 6 ft.) outside the drip line of the building or structure to ensure that precipitation wets the earth around the ground ring and rods (MIL-HDBK-419A and MIL-STD-188-124B).
- Tower ground rings **shall** be installed at least 610 mm (2 ft.) from the tower foundation (ANSI T1.334-2002, section 5.3.1).
- If 2.4 m (8 ft.) ground rods are installed along the ground rings, they **shall** be connected to the ground ring conductor at 3 m to 4.6 m (10 ft. to 15 ft.) intervals (ANSI T1.334-2002), unless otherwise specified.
 - If longer ground rods are used, a larger separation proportional to the increase in rod length may be used.
 - Ground rods **shall** be placed a minimum of one rod length apart from one another along the ground rings (ANSI T1.313-2003, figure 3(a)).
 - Ground rods **shall not** be separated from an adjacent ground rod along the ground ring by more than the sum of their respective lengths. (MIL-HDBK-419A).

4.4.1.7 RADIAL (COUNTERPOISE) GROUNDING CONDUCTORS

For high lightning prone geographical areas, sites normally occupied (such as 911 dispatch centers), sites with high soil resistivity, or when bedrock prohibits the driving of ground rods, radial (counterpoise) grounding (earthing) conductors should be employed to improve equalization of the grounding electrode system (ANSI T1.334-2002, section 5.4), and to help meet the site's grounding electrode system resistance requirements (see "Grounding (Earthing) Electrode System Resistance Requirements" on page 4-46). Radial grounding conductors are conductors installed horizontally in the ground and radiating away from the tower and building.

In typical soil resistivity conditions of 10,000 ohm-cm, the addition of five radial conductors 7.6 m (25 ft) in length may reduce the tower grounding electrode system resistance by a factor of two or three. More importantly, adding radial conductors divides lightning strike current into segments that allow for more effective dissipation of energy into the earth, and away from the equipment building.

When used, radial conductors **shall** meet the following specifications:

- The conductors **shall** radiate away from the building and tower (ANSI T1.334-2002, section 5.4).
- The conductors **shall** be installed at the tower or tower ground ring whenever possible. If the conductors cannot be installed at the tower, installation at the building is acceptable, but should be installed near the RF transmission line entry point.

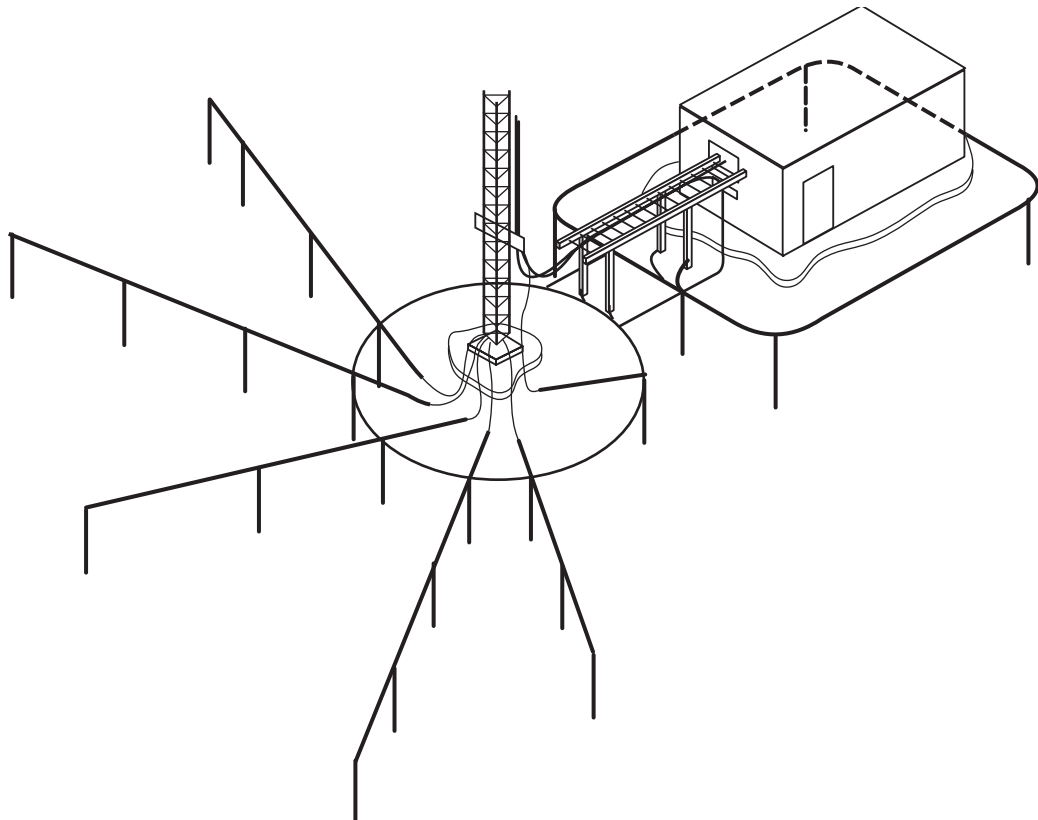

FIGURE 4-19 INSTALLATION OF RADIAL CONDUCTORS

- When radial conductors are used, a minimum of three to five conductors should be used.
- The conductors **shall** be installed equally spaced from one another, as much as practical.

- The conductors **shall** be bonded directly to the tower and tower ground ring (ANSI T1.334-2002, section 5.4). If it is not practical to bond all conductors to the tower, the tower **shall** have additional grounding conductors bonding it to the tower ground ring; 70 mm² (#2/0 AWG) or coarser conductor is recommended in this case.
- Conductor bonding **shall** comply with “Bonding to the External Grounding (Earthing) Electrode System” on page 4-40
- The conductors **shall** be constructed of 35 mm² csa (#2 AWG) or coarser, bare, solid, tinned or un-tinned, copper. See “Grounding (Earthing) Conductors” on page 4-28 for conductor specifications and installation requirements. (ANSI T1.334-2002, section 5.4)
- The conductors **shall** be buried at least 457 mm (18 in.) below ground (ANSI T1.334-2002, section 5.4). When topsoil conditions allow, it is recommended to bury the conductors to a depth of at least 762 mm (30 in.) (ANSI-J-STD-607-A-2002, section C.9.2); this is especially important in areas where the frost line may reach 457 mm (18 in.).
- The minimum length of each conductor **shall** be 7.6 m (25 ft.). If the desired resistance to earth is not achieved at 7.6 m (25 ft.), the radial conductor may be extended to help obtain the desired resistance (ANSI T1.334-2002, section 5.4). The maximum effective length for a single radial conductor is generally considered to be approximately 24.4 m (80 ft.). Adding additional conductors is generally more effective than extending the length of a single conductor.

NOTE: When multiple radial conductors are used, the conductors should be of different lengths to help prevent resonant “ringing” of the tower from a lightning strike.

NOTE: Low resistance in radial (counterpoise) grounding configurations is desirable, but not critical. Low resistance in the dissipating path of strike currents into the earth is of secondary importance when compared to the primary objective of controlling voltage gradients and voltage differences between structures and equipment close to the tower (ANSI T1.334-2002, section 5.4).

- When soil conditions allow, the effectiveness of the radial grounding conductor may be increased by including a ground rod every 4.9 m (16 ft.) (or twice the length of the ground rods) installed as described in “Ground Rods” on page 4-11. See Figure 4-19 on page 4-24 for an example of ground radials.

Figure 4-20 on page 4-26 shows the resistance characteristics of a radial grounding conductor. The resistance to earth of a straight horizontal electrode (radial grounding conductor) may be calculated as follows:

$$R = \frac{\rho}{\pi L} \left[\ln \left[\frac{2L}{(2aD)^{1/2}} \right] \right]^{-1}$$

Where:

$D << L$

R: The resistance of the electrode in ohms

ρ : The soil resistivity in meter-ohms

L: The length of the electrode in metres

a: The electrode radius in meters

D: The electrode depth in meters

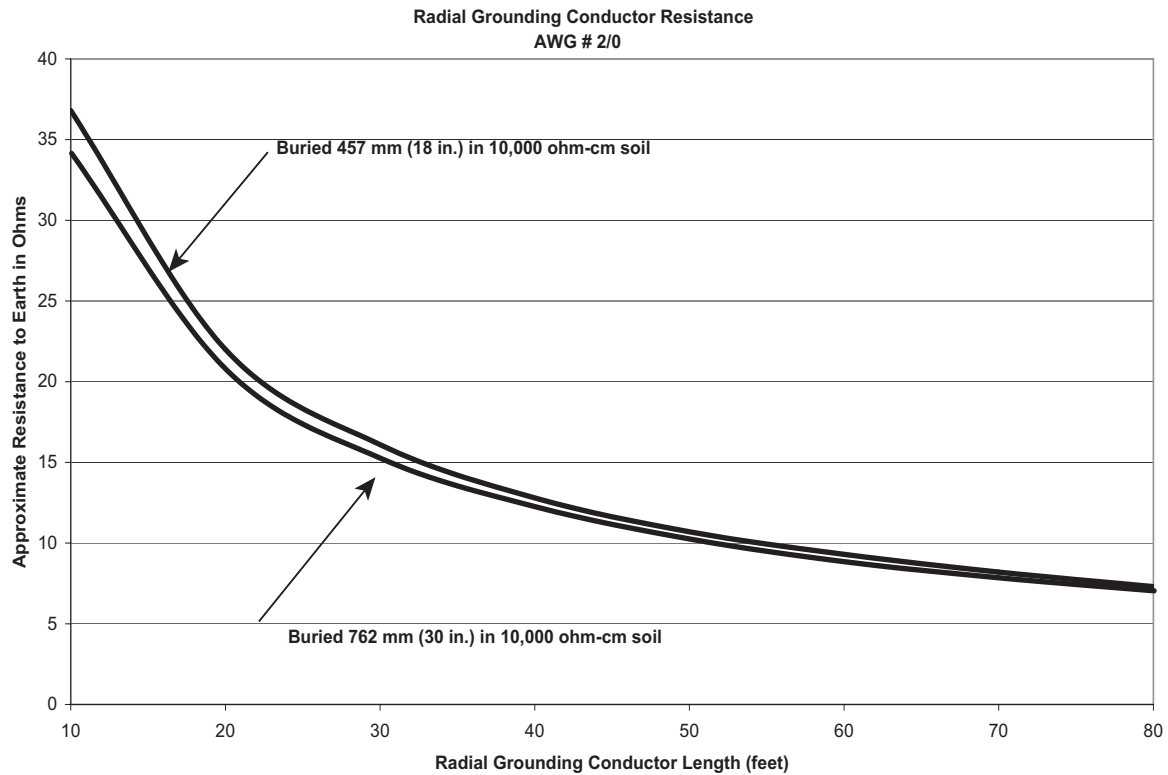
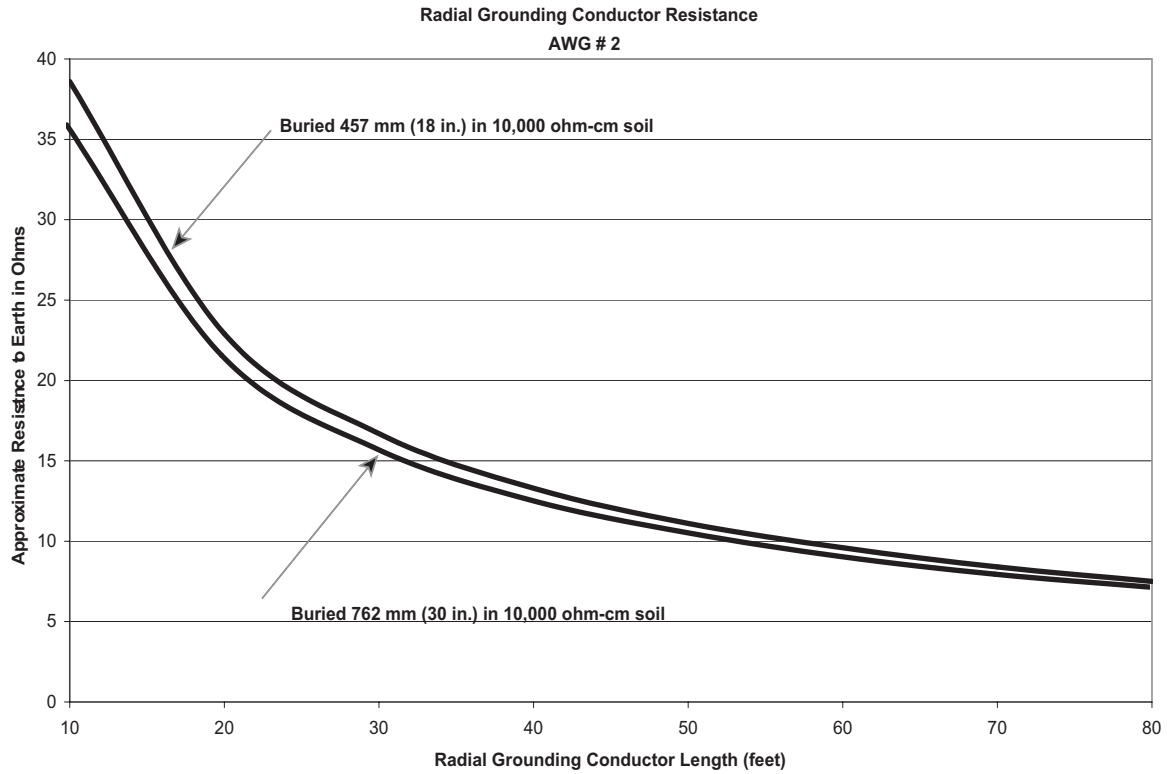

FIGURE 4-20 RESISTANCE CHARACTERISTICS OF A RADIAL GROUNDING CONDUCTOR

4.4.1.8 GROUND TEST WELLS

Ground test wells are not required, but may be desired for troubleshooting and/or inspecting the grounding (earthing) electrode system components. Ground test wells are typically constructed of PVC tubing 203 mm (8 in.) or more in diameter and have a detachable cover to keep debris out. A typical PVC ground test well is shown in Figure 4-21.

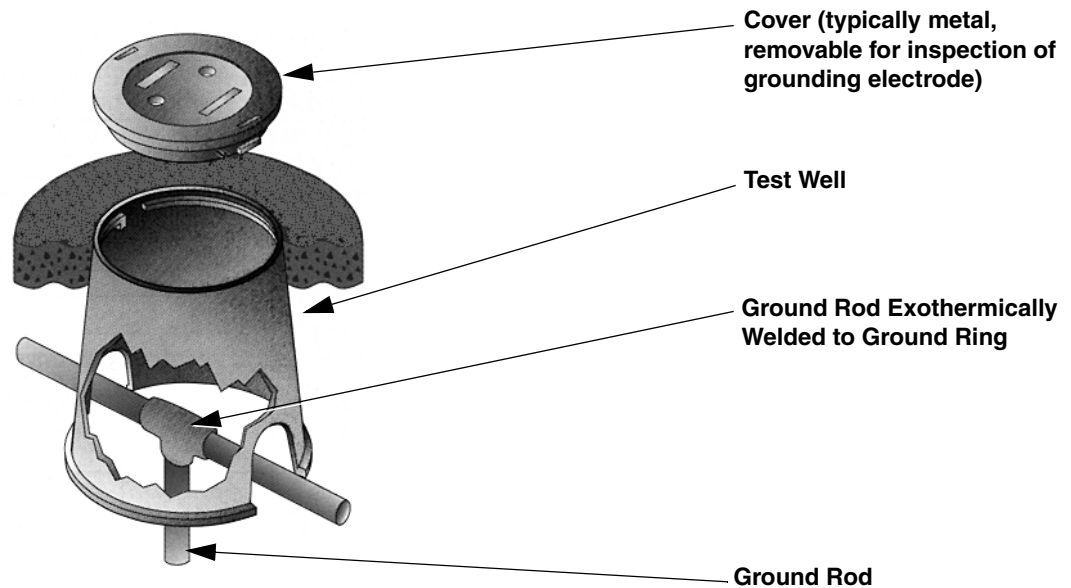

FIGURE 4-21 TYPICAL GROUND TEST WELL

4.4.1.9 GROUNDING (EARTHING) ELECTRODE ENCASEMENT MATERIALS

The resistance to earth of a grounding (earthing) electrode is directly proportional to soil resistivity and inversely proportional to the total area in contact with the soil. Grounding electrode encasement materials (also known as backfill or ground enhancing material) may consist of the following: bentonite or bentonite containing material, concrete, or conductive concrete or cement made with graded granular carbonaceous aggregate in place of the conventional sand or gravel. Grounding electrode encasement materials can absorb water from surrounding soil and have hydration and water retention properties. When placed around grounding electrodes and their interconnecting cable, grounding electrode encasement materials greatly increase the effective area in contact with soil, which in turn reduces the resistance of the grounding electrode system. See MIL-HDBK-419A Volume I, section 2.9 and BS 7430:1998, section 8.5 for more details.

Grounding electrode encasement material may be used as needed to improve the grounding electrode system resistance and/or to protect the grounding electrode system components from corrosive soil (BS 7430:1998, section 19.6.1). Grounding electrode encasement material is generally used with electrolytic ground rods, but may also be used on grounding conductors, standard ground rods, and ground plates as a way to improve the resistance to earth of a grounding electrode system. Requirements for the use of grounding electrode encasement material are as follows:

- Grounding electrode encasement material **shall** be packaged for the purpose of grounding electrode encasement.
- Grounding electrode encasement material **shall** be environmentally safe and approved by the environmental authority having jurisdiction.
- Grounding electrode encasement material **shall** be used in accordance with the manufacturers' instructions.
- Grounding electrode encasement material **shall not** have a corrosive effect on the grounding electrode system components.
- The use of charcoal or petroleum based coke breeze is not recommended as it may result in rapid corrosion of copper electrodes and copper conductors (BS 7430:1998, clause 8.5; BS 6651:1999, clause 18.4.2; and FAA STD 019d-2002, section 3.8.3.5). Charcoal and petroleum based coke typically contains high levels of sulfur, which in the presence of moisture will accelerate corrosion. Coke breeze derived from coal in coke ovens is generally considered acceptable; all the corrosives and volatiles have been cooked off at extremely high temperatures (FAA STD 019d-2002, section 3.8.3.5).

Per MIL-HDBK-419A, the suggested grounding electrode encasement (backfill) material is a mixture of 75 percent gypsum, 20 percent bentonite clay, and 5 percent sodium sulfate. The gypsum, which is calcium sulfate, absorbs and retains moisture and adds reactivity and conductivity to the mixture. Since it contracts very little when moisture is lost, it will not pull away from the ground rod or surrounding earth. The bentonite ensures good contact between the ground rod and earth by its expansion, while the sodium sulfate prevents polarization of the ground rod by removing the gases formed by current entering the earth through the ground rod. This mixture is readily available from cathodic protection distributors as standard galvanic anode backfill. The backfill mixture should be covered with 305 mm (12 in.) of excavated soil. See MIL-HDBK-419A Volume I, section 2.9 for additional information.

4.4.2 GROUNDING (EARTHING) CONDUCTORS

Grounding (earthing) conductors are the conductors used to connect equipment or the grounded circuit of a wiring system to a grounding electrode or grounding electrode system. These conductors may connect grounding electrodes together, form buried ground rings, and connect objects to the grounding electrode system. See BS 7430:1998, clause 3.17 and NFPA 70-2005, Article 100 for additional information.

4.4.2.1 GENERAL SPECIFICATIONS

General specifications for grounding (earthing) conductors are listed below.

- Unless otherwise stated, all below-ground, or partially below-ground, external grounding electrode system conductors **shall** be 35 mm² csa (#2 AWG) or coarser, bare, solid, tinned or un-tinned, copper conductors (ANSI T1.313-2003 and ANSI T1.334-2002, section 5.3). For areas highly prone to lightning, and/or military installations, larger conductors, such as 50 mm² csa (#1/0 AWG) or coarser, should be considered (MIL-HDBK-419A); stranded conductors may be used in this application. Tinned conductors are recommended for stranded conductors.
- Solid, bare, tinned, copper conductors should be used to help minimize galvanic corrosion between tower legs and other parts of the grounding electrode system (ANSI T1.313-2003, section 10.7). See "Dissimilar Metals and Corrosion Control" on page 4-34.

- Grounding electrode conductors **shall** be installed in one continuous length without a splice or joint, unless spliced using irreversible compression-type connectors listed for the purpose or by exothermic welding (NFPA 70-2005, Article 250.64). See “Bonding Methods” on page 4-41 for additional information.
- Above-ground conductors used for bonding individual metallic objects **shall** be 16 mm² csa (#6 AWG) or coarser, tinned or un-tinned, copper conductors (ANSI T1.334, section 5.3.3). See “Metallic Objects Requiring Bonding” on page 4-67 for additional information.
- Above-ground conductors used for bonding multiple metallic objects (used as a ground bus conductor) **shall** be 35 mm² csa (#2 AWG) or coarser, tinned or un-tinned, copper conductors. See “Metallic Objects Requiring Bonding” on page 4-67.
- Above-ground bonding conductors should be jacketed, whenever practical (ANSI T1.334-2002, section 5.1).
- Solid straps or bars may be used as long as the cross-sectional area equals or exceeds that of the specified grounding conductor.

**WARNING**

The AC power system grounding conductors shall be sized appropriately for the electrical service and shall be approved by the authority having jurisdiction.

4.4.2.2 BENDING AND ROUTING GROUNDING (EARTHING) CONDUCTORS

Grounding (earthing) conductors **shall** be run in a direct manner with no sharp bends or narrow loops (ANSI T1.313-2003, section 11.3, and ANSI T1.334-2002, section 13.4). Sharp bends and/or narrow loops increase the impedance and may produce flash points (also see NFPA 780-2004, section 4.9.5). The following requirements apply when installing grounding system conductors:

- Sharp bends **shall** be avoided (ANSI T1.334-2002, section 13.4).
- Grounding conductors **shall** be run as short, straight, and smoothly as possible, with the fewest possible number of bends and curves (ANSI T1.313-2003, section 11.3; ANSI T1.334-2002, section 13.4; and NFPA 70-2005, Articles 800.100, 810.21, and 820.100).
- A minimum bending radius of 203 mm (8 in.) **shall** be maintained, applicable to grounding conductors of all sizes (ANSI T1.313-2003, section 11.3; MIL-STD-188-124B; and NFPA 780-2004, section 4.9.5). A diagonal run is preferable to a bend even though it does not follow the contour or run parallel to the supporting structure. See Figure 4-22.
- All bends and curves **shall** be made toward the ground location (grounding electrode system or ground bar).

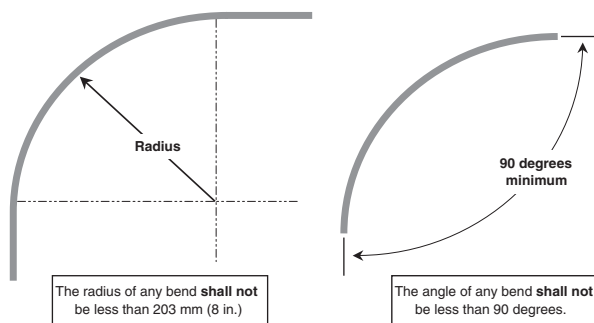

FIGURE 4-22 MINIMUM BENDING RADIUS FOR GROUNDING CONDUCTORS

4.4.2.3 PROTECTING AND SECURING GROUNDING (EARTHING) CONDUCTORS

Above ground external grounding (earthing) conductors, including straps, are exposed to movement by wind and other physical forces that can lead to damage or breakage over time. The following requirements **shall** apply when installing grounding conductors:

- Grounding conductors **shall** be protected where exposed to physical damage (NFPA 70-2005, Articles 250.64, 800.100, 810.20, 820.100; and NFPA 780-2004, section 4.9.11).
- Grounding conductors exposed to physical damage **shall** be protected for a minimum distance of 1.8 m (6 ft.) above grade level (NFPA 780-2004, section 4.9.11.2). Such areas may include, but are not limited to, runways, driveways, school playgrounds, cattle yards, public walks (NFPA 780-2004, section 4.9.11).
- Metallic guards and/or conduits used to protect grounding conductors **shall** be bonded to the grounding conductor at both ends (NFPA 70-2005, Article 250.64 and NFPA 780-2004, section 4.9.11.1).
- The grounding conductor or its enclosure **shall** be securely fastened to the surface on which it is carried (NFPA 70-2005, Articles 250.64 and 810.21; and NFPA 780-2004, section 4.10).
- Grounding conductors **shall** be secured using appropriate hardware intended for the purpose.
- When metallic fasteners are used on bare grounding conductors, fasteners of the same material **shall** be used, or approved bonding techniques **shall** be observed for the connection of dissimilar metals. See “Dissimilar Metals and Corrosion Control” on page 4-34. See NFPA 780-2004, section 4.10.2 for additional information.
- Above ground grounding conductors **shall** be securely fastened at intervals not exceeding 91 cm (3 ft.) where practical. (ANSI T1.334-2002, section 8.3 and NFPA 780-2004, Section 4.10)

4.4.3 EXTERNAL GROUND BUS BAR

The purpose of the external ground bus bar (EGB) is to provide a convenient grounding (earthing) termination point for antenna transmission lines (coaxial cables) and other cables prior to their entry into a building or shelter (ANSI T1.313-2003). Antenna transmission lines and other communications cables with metallic sheaths **shall** be grounded as close as practical to their point of entry into the building or shelter (NFPA 70-2005, articles 770.93, 800.100, 810.20, 820.93, and 820.100).

Requirements for external ground bus bars, when used, are listed below:

- The EGB **shall** be constructed and minimally sized in accordance with Table 4-3 on page 4-32, ensuring the ground bus bar is large enough to accommodate all transmission lines and other grounding connections.
- The EGB **shall** be designed for the purpose of grounding and should be UL listed,
- The EGB **shall** be installed at the point where the antenna transmission lines and other communications cables enter the building or shelter.
- The EGB **shall** be connected directly to the grounding electrode system using a downward run of 35 mm² csa (#2 AWG) or coarser, bare, solid or stranded, tinned or un-tinned, copper conductor; it is recommended to use a larger conductor, such as 120 mm² (#4/0 AWG) (United States National Weather Service Manual 30-4106-2004, “Lightning Protection, Grounding, Bonding, Shielding, and Surge Protection Requirements”). See Figure 4-23. The grounding conductor **shall** be installed in a direct manner with no sharp bends or narrow loops. (See “Bending And Routing Grounding (Earthing) Conductors” on page 4-29.)

- Connection of the grounding electrode conductor to the EGB **shall** use exothermic weld or listed irreversible compression connections (ANSI T1.313-2003).

For reduced impedance to the grounding electrode system, the EGB can be connected to the grounding electrode system using solid copper strap. Relatively small copper strap has significantly less inductance (impedance to lightning) than large wire conductors. For example, 38.1 mm (1.5 in.) copper strap has less inductance than 70 mm² csa (#2/0 AWG) wire. To further reduce the inductance to ground, several copper straps can be installed across the entire length of the external ground bus bar and routed down to the external grounding ring. See Figure 4-23.

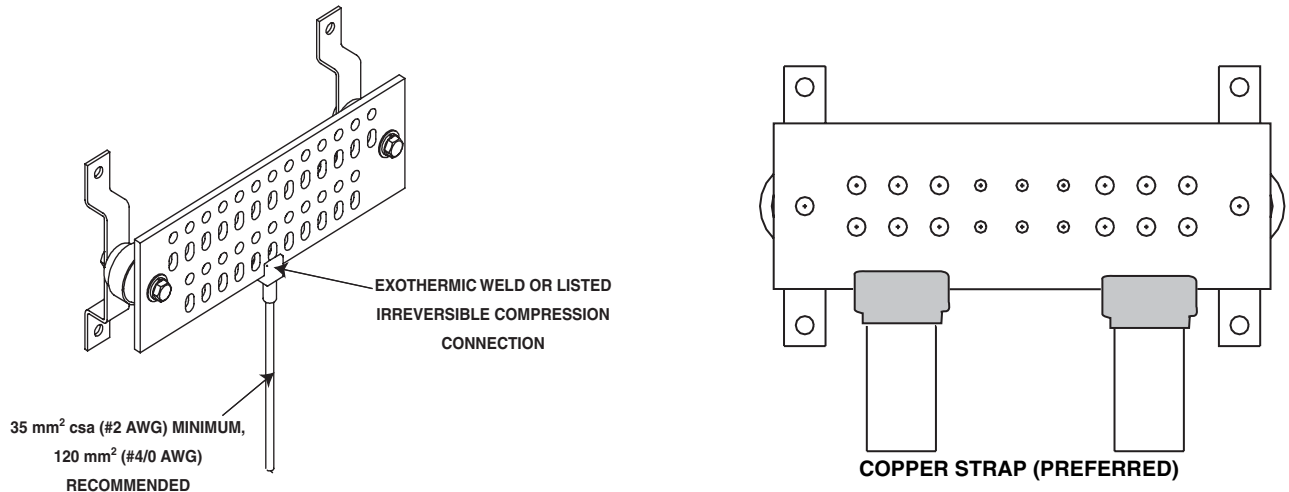

FIGURE 4-23 TYPICAL EXTERNAL GROUND BUS BARS

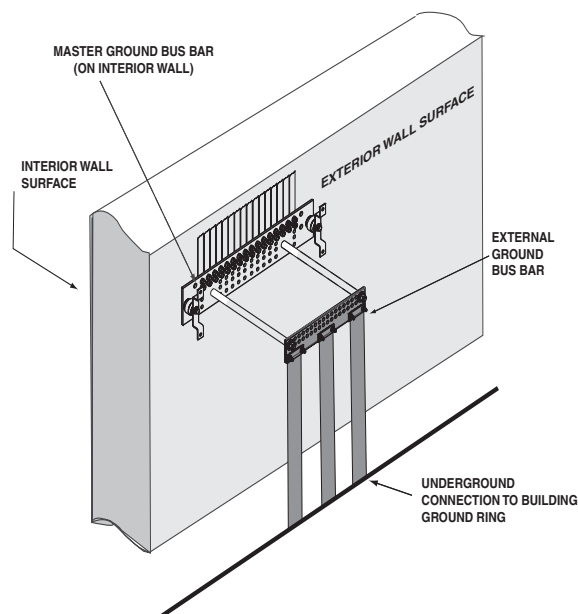

FIGURE 4-24 INTEGRATED CABLE ENTRY PORT WITH GROUND STRAPS

TABLE 4-3 EXTERNAL GROUND BUS BAR SPECIFICATIONS (WHEN REQUIRED)

Item	Specification
Material	Bare, solid Alloy 110 (99.9%) copper bus bar or plate of one piece construction. May be tin-plated.
Minimum Dimensions (ANSI-J-STD-607-A-2002 and NFPA 70-2005, Article 250.64)	Height: 51 mm (2 in.) Thickness: 6.35 mm (0.25 in.) Length: Variable to meet the application requirements and allow for future growth. 305 mm (12 in.) is recommended as the minimum length.
Mounting brackets	Stainless steel
Insulators	Polyester fiberglass 15 kV minimum dielectric strength flame resistant per UL 94 VO classification
Conductor mounting holes	Number dependent on number of conductors to be attached Holes to be 11 mm (0.4375 in.) minimum on 19 mm (0.75 in.) centers to permit the convenient use of two-hole lugs.
Method of attachment of grounding electrode conductor	Exothermic welding Irreversible crimp connection

IMPORTANT: For improved lightning protection at the site, the RF transmission line entry point and EGB should be installed as low to the ground as practical; 610 mm (2 ft.) is the recommended maximum height for the RF transmission line entry point. (United States National Weather Service Manual 30-4106-2004, “Lighting Protection, Grounding, Bonding, Shielding, and Surge Protection Requirements”.) See “Design Considerations to Help Reduce Effects of Lightning” on page 2-19.

4.4.3.1 TOWER GROUND BUS BAR

The purpose of the tower ground bus bar (TGB) is to provide a convenient termination point on the tower for multiple transmission line (coaxial) grounding (earthing) conductors. The tower ground bus bar should be an integral part of the tower construction. If the tower ground bus bar is not part of the tower construction, it **shall** be constructed and minimally sized in accordance with Table 4-4 on page 4-34, ensuring the ground bus bar is large enough to accommodate all coaxial cable connections and connection to the grounding electrode system.

The requirements for installing tower ground bus bars are as follows:

- Where a galvanized tower is not protected against precipitation run-off from copper and copper alloys, the tower ground bus bar (TGB) **shall** be constructed of tinned copper. See “Methods To Help Reduce Corrosion” on page 4-38.
- The tower ground bus bar **shall** be installed below the transmission line ground kits, near the area of the tower at the point where the antenna transmission lines transition from the tower to the shelter.
- The tower ground bus bar **shall** be connected to the tower grounding electrode system with a 35 mm² csa (#2 AWG) or coarser, bare, solid, tinned, copper conductor.

- For reduced impedance to earth, the tower ground bus bar may be directly bonded to the tower, using hardware of materials suitable for preventing dissimilar metal reactions, if possible and allowed by the tower manufacturer. This is in addition to the required grounding conductor as described above.
- The grounding conductors **shall** be run as short, straight, and smoothly as possible. See “Bending And Routing Grounding (Earthing) Conductors” on page 4-29.
- The grounding conductor may be sleeved in PVC for protection if desired (ANSI T1.313-2003, section 11.4). This may be required in order to keep the grounding conductor from making incidental contact with the tower.

For reduced impedance to the grounding electrode system, the TGB can be connected to the external grounding electrode system using solid copper strap. Relatively small copper strap has significantly less inductance (impedance to lightning) than large wire conductors. For example, 38.1 mm (1.5 in.) copper strap has less inductance than 70 mm² csa (#2/0 AWG) wire. To further reduce the inductance to ground, several copper straps can be installed across the entire length of the tower ground bus bar and routed down to the external grounding ring.

Additional ground bus bars may be installed at different heights along the vertical length of the tower for bonding multiple transmission line ground kits to the tower, if not already included as part of the tower structure. The additional ground bus bars **shall** be bonded directly to the tower using tower manufacturer approved methods. Bonding to the tower may include the following options:

- Bolting a tin-plated bus bar directly to the tower structure using stainless steel hardware. In this case, a grounding conductor is not required.
- Securing a bus bar to the tower using appropriate mechanical hardware. Electrically bonding the bus bar to the tower using a grounding conductor. The grounding conductor should bond to the tower using appropriate hardware, such as stainless steel beam clamps, or stainless steel band/strap type clamp. The grounding conductor **shall** bond to the bus bar using exothermic weld, irreversible compression connectors, or listed compression two-hole lugs.

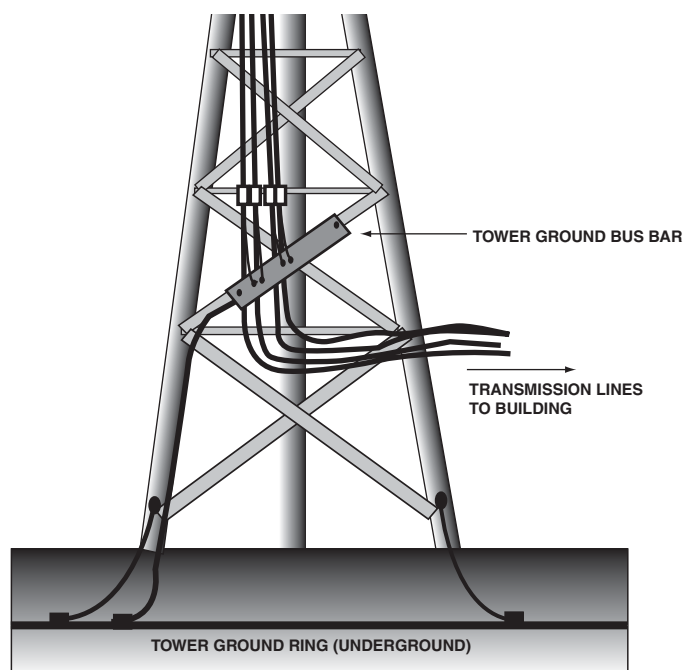

FIGURE 4-25 TYPICAL TOWER GROUND BUS BARS

TABLE 4-4 TOWER GROUND BUS BAR SPECIFICATIONS

Item	Specification
Material	Bare, solid Alloy 110 (99.9%) copper bus bar or plate of one piece construction. Should be tin-plated if installing on a galvanized tower. (See “Dissimilar Metals and Corrosion Control” on page 4-34 for information regarding tower corrosion related to copper bus bars.)
Minimum Dimensions (ANSI-J-STD-607-A-2002 and NFPA 70-2005, Article 250.64)	Height: 51 mm (2 in.) Thickness: 6.35 mm (0.25 in.) Length: Variable to meet the application requirements and allow for future growth. 305 mm (12 in.) is recommended as the minimum length.
Mounting brackets	Stainless steel
Conductor mounting holes	Number dependent on number of conductors to be attached Holes to be 11 mm (0.4375 in.) minimum on 19 mm (0.75 in.) centers to permit the convenient use of two-hole lugs.
Method of attachment of grounding electrode conductor	Exothermic welding Irreversible crimp connection

4.5 DISSIMILAR METALS AND CORROSION CONTROL

Although the type of metals used in a grounding (earthing) electrode system do not affect the resistance to earth of the grounding electrode system, consideration should be given to select a metal that is resistance to corrosion in the type of soil in which it will be installed. The two areas that should be considered regarding the corrosion resistance of a metal are the compatibility with the soil itself and possible galvanic corrosion effects when it is electrically connected to neighboring metals at the site. (BS 7430:1998)

4.5.1 CORROSION RELATED TO SOIL TYPE

The compatibility of a metal with soil is determined by the chemical composition of the soil. The chemical composition factors associated with the corrosion of metals in contact with the soil are as follows: acidity or alkalinity (pH), salt content, soil porosity (aeration), and the presence of anaerobic bacteria. (BS 7430:1998 and TIA/EIA-222-F-R2003)

The following list gives a general representation of the aggressiveness of soils, listed in order of increasing aggressiveness (BS 7430:1998):

- Gravelly soils (Least Aggressive)
- Sandy soils
- Silty soils (loam)
- Clays
- Peat and other organic soils
- Made up soils containing cinders (Most Aggressive)

The least aggressive soils tend to be those having a high resistivity. The resistivity of soil can be measured, which provides an indication of corrosiveness under aerated conditions (BS 7430:1998). See “Performing Soil Resistivity Test” on page B-6 for measurement details. Soil with a resistivity below 2,000 ohm centimeters ($\Omega\text{-cm}$) is generally considered to be highly corrosive (TIA/EIA-222-F-R2003).

More details about the aggressiveness of soils can be obtained by measuring the redox (from the words reduction and oxidation) potential of the soil, which indicates the risk of corrosion due to the presence of anaerobic bacteria (BS 7430:1998). Test equipment required to measure redox potential is commercially available. The procedure required to test the redox potential can be found in ISO 11271:2002(E). A geotechnical firm may be required to measure the redox potential of the soil.

General guidance on the corrosiveness of some grounding electrode system metals in relation to soil composition is given below in Table 4-5 (BS 7430:1998). A geotechnical firm may be required to determine all of the listed soil parameters.

TABLE 4-5 CORROSION RESISTANCE PROPERTIES OF COMMON GROUNDING ELECTRODE SYSTEM METALS AS RELATED TO SOIL COMPOSITION

Soil Parameter		Grounding Electrode Metal		
		Copper	Galvanized Steel	Austenitic Stainless Steel*
Resistivity ($\Omega\text{-cm}$)	< 700	Slightly Reduced	Moderately Reduced	Slightly Reduced
	700 to 4000	Slightly Reduced	Moderately Reduced	Generally Unaffected
	> 4000	Generally Unaffected	Generally Unaffected	Generally Unaffected
Redox Potential (mV)	< 200	Moderately Reduced	Considerably Reduced	Moderately Reduced
	200 to 400	Slightly Reduced	Slightly Reduced	Generally Unaffected
	> 400	Generally Unaffected	Generally Unaffected	Generally Unaffected
Moisture Content (%)	< 10	Generally Unaffected	Generally Unaffected	Generally Unaffected
	10 to 80	Slightly Reduced	Moderately Reduced	Slightly Reduced
	> 80	Slightly Reduced	Slightly Reduced	Slightly Reduced
Dissolved				
Salts		Moderately Reduced	Moderately Reduced	Slightly Reduced
Chlorides		Moderately Reduced	Moderately Reduced	Moderately Reduced
pH				
Acidic	< 6	Moderately Reduced	Considerably Reduced	Slightly Reduced
Neutral	6 to 8	Generally Unaffected	Generally Unaffected	Generally Unaffected
Alkaline	> 8	Slightly Reduced	Moderately Reduced	Generally Unaffected
Organic Acids	> 8	Considerably Reduced	Moderately Reduced	Slightly Reduced
* Austenitic stainless steel shall be formed from 18% chromium and 8% nickel (18/8 stainless steel), per UL 467-2004, section 9.2.6. Table based on information from BS 7430:1998.				

The following general observations can be made from Table 4-5:

- Copper-clad steel or solid copper ground rods are one of the better and commonly used materials for grounding electrodes. However, the adverse effect of dissolved salts, organic acids and acid soils generally should be noted (BS 7430:1998, clause 11).
- Copper or copper-clad ground rods should not be used in soils where organic acids are present, unless protective measures are taken, such as encasing the ground rods in a grounding electrode encasement material. Organic acids are commonly found in poorly drained and poorly aerated soils. See “Grounding (Earthing) Electrode Encasement Materials” on page 4-27.
- Galvanized ground rods should not be used in soils with a redox potential below 200 mV, unless protective measures are taken, such as encasing the ground rods in a grounding electrode encasement material. See “Grounding (Earthing) Electrode Encasement Materials” on page 4-27.
- Galvanized ground rods should not be used in acidic soils with a pH below 6.

4.5.2 GALVANIC CORROSION

Galvanic corrosion (also called dissimilar metals corrosion) refers to corrosion damage induced when two dissimilar metals are electrically connected and coupled through an electrolyte (such as soil). When a metal is electrically connected to a dissimilar metal, a difference of potential exists between the two metals. If the dissimilar metals are also in contact with a low resistivity soil, a complete circuit will exist. Current will flow from one metal to the other due to the electrical connection and return path through the soil. This naturally occurring phenomenon is why current is obtained from a battery when its terminals are electrically connected to a load (TIA/EIA-222-F-R2003). See Figure 4-26 for an example of installations with and without galvanic corrosion.

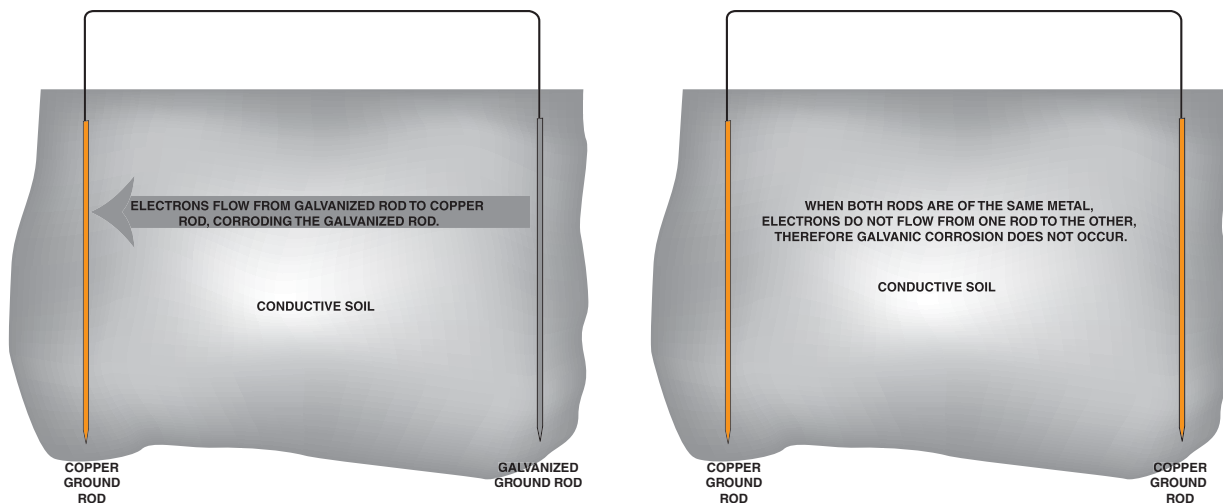

FIGURE 4-26 INSTALLATIONS WITH AND WITHOUT GALVANIC CORROSION

Metals may be listed in order of their respective potentials; such a list is called a galvanic series. A galvanic series of commonly used grounding (earthing) electrode system metals and alloys is given in Table 4-6 (from TIA/EIA-222-F-R2003 and MIL-HDBK-419A). When a complete circuit exists, corrosion occurs on the metal listed higher in the galvanic series. The metal listed higher in the galvanic series (anode) is where current exits and travels through the soil toward the metal listed lower on the galvanic series (cathode). The galvanic series of commonly used metals and alloys is as follows:

TABLE 4-6 GALVANIC SERIES OF COMMON METALS

Anodic (Active) End
Magnesium
Zinc (material used to galvanize steel)
Aluminum
Steel, Iron
Lead, Tin
Brass, Copper, Bronze
Silver
Graphite
Cathodic (Most Noble) End

The rate of corrosion mainly depends on the conductivity of the soil and the relative position of the metals in the galvanic series. The higher the soil conductivity (low resistivity), and the further apart the metals are in the galvanic series, the faster the rate of corrosion (TIA/EIA-222-F-R2003). To some extent, the rate of corrosion also depends on the relative surface areas of the metals (BS 7430:1998 and IEEE STD 142-1991). A small anode (such as a galvanized steel guy anchor point) and large cathode (such as a copper grounding electrode system) should not be installed; in this case, the total current is confined to a small space and the current density is large, therefore, corroding the galvanized steel (IEEE STD 142-1991).

General guidance on the suitability of metals for bonding together with neighboring metals is given below in Table 4-7 (BS 7430:1998); both metals are assumed to be located in the earth. The bond between the neighboring metals could be located above or below ground.

TABLE 4-7 SUITABILITY OF METALS FOR BONDING

Metal assumed to have the Larger Surface Area	Electrode metal or item assumed to have the Smaller Surface Area			
	Steel	Galvanized Steel	Copper	Tinned Copper
Galvanized Steel	Suitable	Suitable	Suitable	Suitable
Steel in Concrete	Not Suitable	Not Suitable	Suitable	Suitable
Galvanized Steel in Concrete	Suitable	*	Suitable	Suitable
Lead	Suitable	*	Suitable	Suitable

Key:
 Suitable = Materials suitable for bonding.
 Not Suitable = Materials not suitable for bonding.
 * = Materials suitable for bonding, but the galvanizing on the smaller surface may suffer.
 This table is based on Table 8 of BS 7430:1998.

4.5.3 MISCELLANEOUS GENERAL INFORMATION

- Galvanized steel is strongly electronegative to copper and steel encased in concrete, therefore, careful consideration must be given before galvanized ground rods are used at a site that contains a concreted encased electrode. (See BS 7430:1998, clause 11.2 for additional information.) See “Concrete-Encased Electrodes” on page 4-20.
- Steel encased in concrete has a potential similar to that of copper; therefore, may be bonded to copper or copper-clad ground rods. (See BS 7430:1998 and IEEE STD 142-1991 for additional information.)

4.5.4 METHODS TO HELP REDUCE CORROSION

Listed below are some general requirements and guidelines to help prevent corrosion of the grounding (earthing) electrode system and other metallic items at the communications site:

- The same metal **shall** be used throughout the grounding electrode system whenever possible.
- Aluminum or copper-clad aluminum grounding conductors **shall not** be used (NFPA 70-2005, Article 250.64).
- Copper **shall not** come into incidental contact with galvanized steel.
- Copper **shall not** come into incidental contact with aluminum.
- Precipitation run-off from copper and copper alloys can attack galvanized parts (BS 6651:1999 and IEC 61024-1-2, section 5.2); therefore, bare copper conductors or copper bus bars **shall not** be installed above galvanized steel, such as a tower, unless the steel is protected against the precipitation run-off (IEC 61024-1-2, section 5.2).

**CAUTION**

Extremely fine particles are shed by copper parts, which result in severe corrosive damage to galvanized parts, even where the copper and galvanized parts are not in direct contact (IEC 61024-1-2, section 5.2).

- Where a galvanized tower is not protected against precipitation run-off from copper and copper alloys, the tower ground bus bar (TGB) **shall** be constructed of tinned copper or other suitable material.
- Where tinned conductors or galvanized ground rods are used, care **shall** be exercised during installation so that surfaces are not damaged. If surfaces of these ground elements are damaged, the potential for deterioration from galvanic action increases (ANSI T1.313-2003, section 11.5 and ANSI T1.334-2002, section 13.6).
- Exothermically welded joints on galvanized material **shall** be coated with a zinc-enriched paint to prevent corrosion.
- Copper/aluminum joints **shall** be avoided wherever possible. In cases where they cannot be avoided, the connections **shall** be exothermically welded or made using an AL/CU listed bimetallic transition connector (IEC 61024-1-2, section 5.2). Use a listed conductive anti-oxidant compound on all mechanical connections (ANSI T1.334-2002, section 9).
- Solid, bare, tinned copper conductor should be used to minimize galvanic corrosion between tower legs and other parts of the grounding electrode system (ANSI T1.313-2003, section 10.7).
- Grounding connections to galvanized towers **shall** be exothermally welded whenever possible. When exothermic welding is not possible, the tower grounding conductor **shall** be constructed of tinned-copper (IEC 61024-1-2, section 5.2).
- Select appropriate grounding electrode system components using Table 4-5.
- When soil conditions are not favorable, such as highly acidic or alkaline, grounding electrode system component corrosion may be reduced by encasing the components in a grounding electrode encasement material. See “Grounding (Earthing) Electrode Encasement Materials” on page 4-27, and BS 7430:1998, section 19.6.1, for additional information.
- When soil conditions are not favorable, such as highly acidic or alkaline, grounding electrode system component corrosion may be reduced by installing electrolytic ground rods encased in a grounding electrode encasement material. See “Grounding (Earthing) Electrode Encasement Materials” on page 4-27 and “Electrolytic Ground Rods” on page 4-16.
- When soil conditions are not favorable, such as highly acidic or alkaline, the useful life of a copper ground rod can be extended by using solid copper ground rods instead of copper-clad rods, if soil conditions allow driving of the solid copper rod.
- When soil conditions are not favorable, such as highly acidic or alkaline, the useful life of buried grounding conductors can be extended by using larger conductors, such as 70 mm² csa (#2/0 AWG) instead of 35 mm² (#2 AWG).
- Use a listed conductive anti-oxidant compound on all mechanical connections (ANSI T1.334-2002, section 9). The anti-oxidant compound **shall** be liberally installed between the two metals (see Figure 4-27 on page 4-40).
- See “Guy Anchor Points” on page 4-54 for information regarding proper grounding techniques to help minimize galvanic corrosion of the guy anchor.

4.6 BONDING TO THE EXTERNAL GROUNDING (EARTHING) ELECTRODE SYSTEM

4.6.1 REQUIREMENTS

All below-grade grounding (earthing) electrode system connections **shall** be joined using exothermic welding or listed irreversible high-compression fittings compressed to a minimum of 13.3 tonnes (12 tons) of pressure, or as otherwise required by the specific component manufacturer (ANSI T1.313-2003, figure 3(a)). Manufacturer requirements **shall** be followed for all connections. Connectors and fitting used **shall** be listed for the purpose, for the type of conductor, and for the size and number of conductors used.

All above grade grounding electrode system connections (such as grounding electrode conductor connection to ground bus bars and tower legs) **shall** be joined using exothermic welding, or listed irreversible high-compression fittings compressed to a minimum of 13.3 tonnes (12 tons) of pressure, or as otherwise required by the specific component manufacturer (ANSI T1.313-2003, figure 3(a)).

All above grade bonding connections (such as bonding to ancillary equipment, or bonding coaxial ground kits to bus bars) **shall** be joined using exothermic welding, listed lugs, listed pressure connectors, listed clamps, or other listed means required by the specific component manufacturer. Connecting hardware **shall** be designed for the purpose, for the type of conductor, and for the size and number of conductors used. All mechanical connections **shall** be coated with a listed conductive anti-oxidant compound. The anti-oxidant compound **shall** be liberally applied between the two metals (see Figure 4-27)(NFPA 70-2005, Article 250.70).

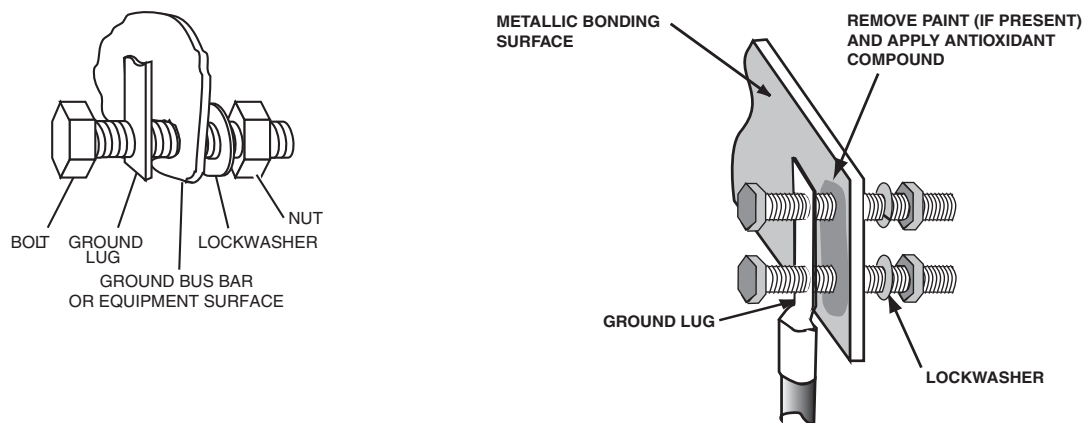

FIGURE 4-27 PROPER LOCATION OF WASHER WHEN CONNECTING GROUNDING LUG

NOTE: In some instances, exothermic welding may not be possible or may be prohibited by the specific component manufacturer (such as towers or fences); in these cases, other suitable means for bonding is allowed.

Connecting hardware **shall** be listed for the purpose, for the type of conductor, and for the size and number of conductors used. All mechanical connections **shall** be coated with a listed conductive anti-oxidant compound (NFPA 70-2005, Article 250.70).

All exothermic and irreversible compression connections for use on external grounding applications **shall** be UL 467 listed. Copper connectors **shall** maintain minimum 88% conductivity rating. Compression systems **shall** include crimped die index and company logo for purposes of inspection. Aluminum **shall not** be used for connection purposes.

Bonding **shall** be performed so that a suitable and reliable connection exists. The following requirements **shall** be observed when bonding grounding connections:

- Paint, enamel, lacquer and other nonconductive coatings **shall** be removed from threads and surface areas where connections are made to ensure good electrical continuity (NFPA 70-2005, Article 250.12). Use of a star washer does not alleviate the requirement to remove nonconductive coatings from attachment surfaces. See Figure 4-27 for proper star/lock washer location. Star washers should only be used as a lock washer.
- After bonding to a painted or galvanized structure, the area **shall** be painted with a zinc-enriched paint.
- Exothermic welding is the preferred method for bonding connections to the external grounding electrode system.
- Two-hole lugs secured with fasteners in both holes are preferred over single-hole lugs. Two-hole lugs prevent movement of the lug.
- When connecting ground lugs or compression terminals to ancillary equipment, such as air conditioners and vent hoods, a lock washer **shall** be placed on the nut side. See Figure 4-27. Sheet metal screws and/or self-tapping screws **shall not** be used.
- All mechanical connections **shall** be coated with a listed conductive anti-oxidant compound (NFPA 70-2005, Article 250.70, ANSI T1.334-2002, section 9). The anti-oxidant compound **shall** be liberally installed between the two metals (see Figure 4-27 on page 4-40).

4.6.2 BONDING METHODS

The following paragraphs describe acceptable methods for bonding to the external grounding (earthing) electrode system. Exothermic welding and the use of listed irreversible high-compression fittings are the only acceptable methods for below-grade bonding. Other mechanical connection methods **shall not** be used below-grade.

4.6.2.1 EXOTHERMIC WELDING

Exothermic welding is a method of welding electrical connections without an external heat source, such as electricity or gas. The process is based on the reaction of granular metals which when combined, produce a molten metal. This reaction, which is completed in seconds, takes place in a crucible. The liquid metal flows from the crucible into a mold where it meets the ends of the conductors to be welded. The temperature of the molten metal is sufficient to fuse the metal of the conductors, resulting in a welded molecular bond. Exothermic welding alloys are available for aluminum, copper, and copper to steel connections.

**WARNING**

To help prevent injury from molten metal or sparks and to reduce the risk of fire, follow the exothermic welding manufacturer's safety warnings and requirements.

- Heavy clothing, work shoes or boots, gloves, and safety glasses **shall** be worn when performing exothermic welding,
- Exothermic welding **shall not** be performed unless another person capable of rendering first aid is present. A suitable fire extinguisher **shall** be close by with an attendant during the process.
- Observe the following prerequisites for exothermic welding:
 - Follow the manufacturer's recommendations.
 - Use the proper molds for the conductors being welded.
 - Use the proper weld material for the metals being welded.
 - Properly clean all metal parts prior to welding.
 - Properly dry all metal parts and molds prior to welding.

The exothermic welding process is shown in Figure 4-28.

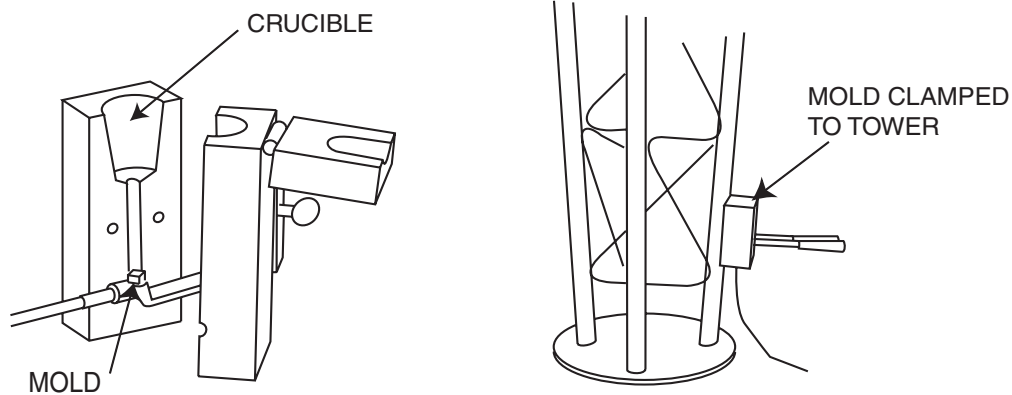

FIGURE 4-28 EXOTHERMIC WELDING MOLD (LEFT) AND PROCESS (RIGHT)

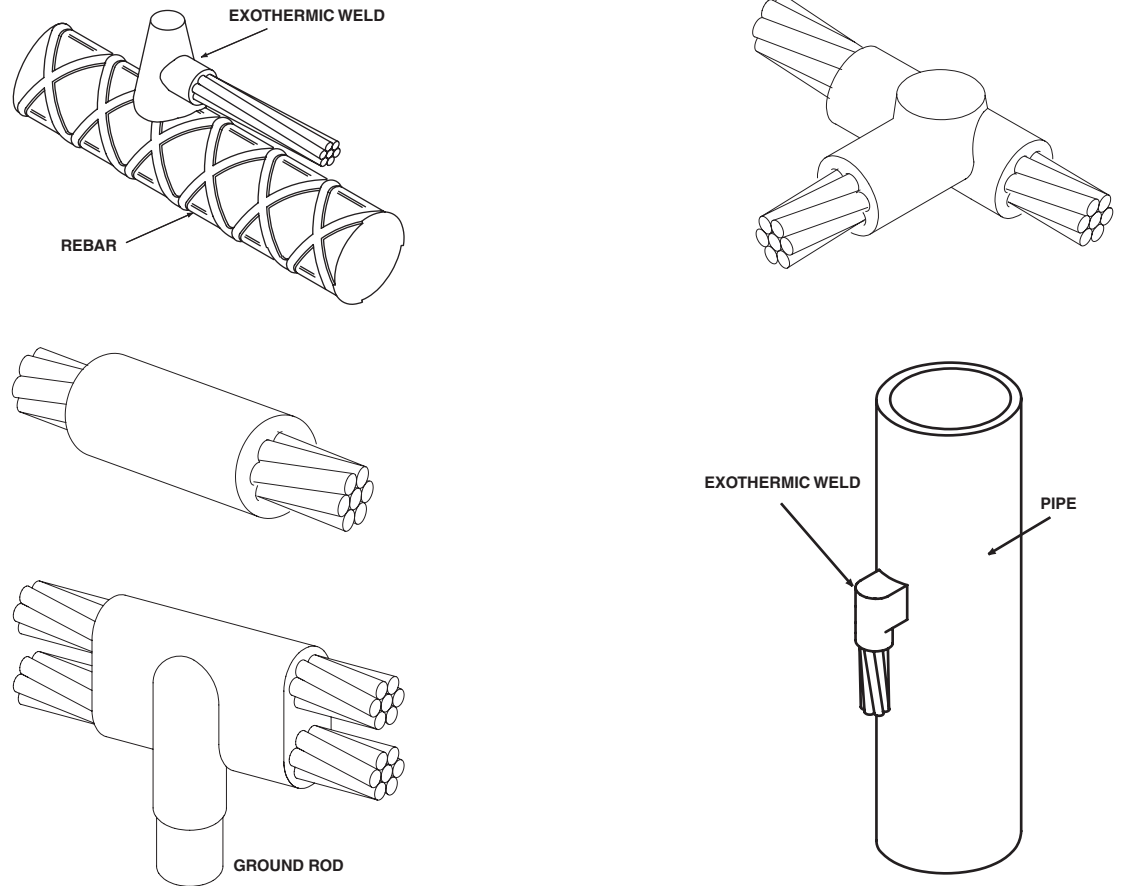

FIGURE 4-29 EXAMPLES OF COMPLETED EXOTHERMIC WELDS

4.6.2.2 IRREVERSIBLE HIGH COMPRESSION FITTINGS



WARNING

Wear safety glasses, hard hat, and steel-toes shoes when working with high-compression fittings.

When using irreversible high-compression fittings, always use the compression tool recommended by the manufacturer in accordance with the instructions provided by the manufacturer. Use fittings made of the same material as the materials being bonded to avoid dissimilar metal reactions. See Figure 4-30 for examples of high-compression fittings.

- Use fittings properly sized for the conductors being bonded.
- Use fittings and compression tools rated at 13.3 tonnes (12 tons) of force.
- Use only UL-listed connectors.
- To ensure good contact, clean conductors using a wire brush before crimping.
- Coat all crimped connections with a listed conductive antioxidant compound before crimping.

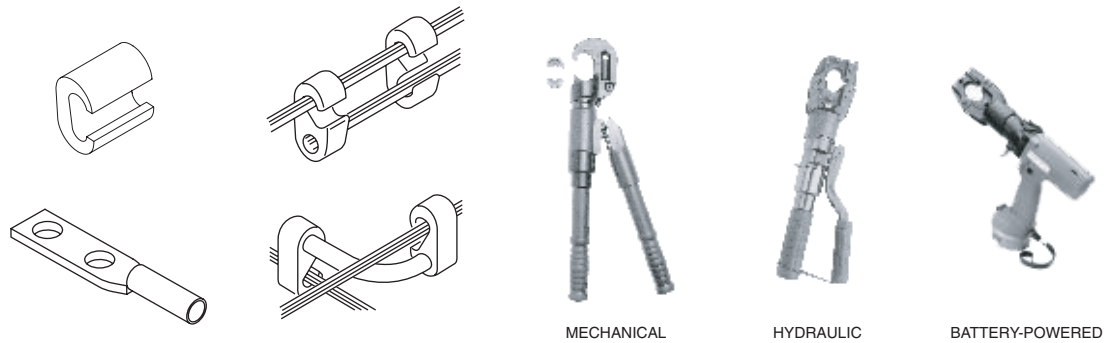

FIGURE 4-30 HIGH-COMPRESSION CONNECTORS AND TYPICAL CRIMPING TOOLS

4.7 MINIMUM SITE GROUNDING (EARTHING) REQUIREMENTS

This section provides the minimum grounding (earthing) requirements for installing a grounding electrode system at a communications site and for bonding site equipment to the grounding electrode system. Reasonable attempts **shall** be made to achieve the grounding electrode system resistance design goal, as defined in “Grounding (Earthing) Electrode System Resistance Requirements” on page 4-46

The requirements for installing a typical grounding electrode system are as follows:

- Perform a soil resistivity test at the site as described in Appendix B, “Soil Resistivity Measurements”
- Calculate the resistance of a single ground rod as described in “Interpreting Test Results” on page B-10.
- Determine the resistance requirement of the grounding electrode system, based on the site type (“Light Duty” or “Standard Duty” site). See “Grounding (Earthing) Electrode System Resistance Requirements” on page 4-46.

4.7.1 TYPE “A” SITE - LIGHT DUTY

- Determine if the single ground rod will meet the minimum 25 ohm requirement. If the single ground rod does not meet the 25 ohm requirement, an additional ground rod, or other grounding (earthing) electrode, will be required. See “Type “A” Site Grounding (Earthing)” on page 4-48 for additional information.
- Install the ground rod(s) as described in “Type “A” Site Grounding (Earthing)” on page 4-48 and elsewhere throughout this chapter.

NOTE: It is recommended to use two grounding electrodes as the minimum installation, even if 25 ohms is achieved with a single grounding electrode.

4.7.2 TYPE “B” SITE - STANDARD DUTY

- Using a site drawing, determine where to install the minimum required ground rods, while maintaining equal separation between rods. See “External Building and Tower Ground Ring” on page 4-22 for additional information regarding ground rod placement requirements along ground rings.
- Determine if radial grounding (earthing) conductors should be installed at the site, such as when the site is located in a high lightning prone geographic area or when the site is normally occupied, such as a dispatch center. See “Radial (Counterpoise) Grounding Conductors” on page 4-24.
- Calculate the resistance of the grounding electrode system using “Calculating Resistance of Complex Ground Rod Systems” on page B-30.
- If the required resistance cannot be met, recalculate using one or more of the follow techniques:
 - Recalculate using longer ground rods.
 - Recalculate using radial grounding conductors if not already included. See “Radial (Counterpoise) Grounding Conductors” on page 4-24.
 - Recalculate using closer spaced ground rods, resulting in more ground rods at the site (do not install ground rods closer than one ground rod length apart from other ground rods).
- If the resistance requirement still cannot be met, see “Special Grounding (Earthing) Situations” on page 4-88.
- Develop a detailed site grounding electrode system drawing based on the previous steps.
- Install the grounding electrode system using components and techniques as specified throughout this chapter.
- Test the grounding electrode system resistance to earth as described in Appendix D.
- Bond all external metal objects to the grounding electrode system as required throughout this chapter.

4.7.3 SPECIAL GROUNDING (EARTHING) SITUATIONS

- See “Calculating Multiple Grounding Electrode System Resistance (Electrodes In Straight Line)” on page B-19 for the information required to calculate the resistance to earth of multiple ground rods installed in a straight line.
- See “Multiple Grounding Electrode System Resistance Calculation (Electrodes In Ring Configuration)” on page B-24 for the information required to calculate the resistance to earth of multiple ground rods installed in a ring configuration.
- See “Calculating Multiple Grounding Electrode System Resistance (Ground Rod Grid Configuration)” on page B-24 for the information required to calculate the resistance to earth of multiple ground rods installed in a ground rod grid configuration.

4.7.4 GROUNDING (EARTHING) ELECTRODE SYSTEM RESISTANCE REQUIREMENTS

In order to disperse lightning energy into the earth without causing dangerous over-voltage, the shape and dimensions of the grounding (earthing) electrode system are more important than a specific resistance value of the grounding electrode system. However, a low resistance grounding electrode system is generally recommended (IEC 61024-1-2). Attempts should be made to reduce the grounding electrode system resistance to the lowest practical value (MIL-HDBK-419A, section 2.2.3).

NOTE: Although grounding electrode system resistance is important and should be met whenever possible, it alone does not determine the suitability of the grounding electrode system to properly dissipate and control lightning energy. The resistance of the grounding electrode system is only a general measure of merit. Proper design and installation of the grounding electrode system, installation of ground rings, ground rods, radial grounding conductors, and the bonding of systems and equipment, is as important as the resistance to earth.

Effective grounding electrode system shape and dimensions are achieved through the proper installation of the required and recommended grounding electrode system components listed throughout this chapter. The required and recommended grounding electrode system components are, but not limited to, the following:

- **Building ground ring.** See “External Building and Tower Ground Ring” on page 4-22.
- **Tower ground ring.** See “External Building and Tower Ground Ring” on page 4-22.
- **Ground rods** properly installed and spaced around the building and tower ground rings. See “Ground Rods” on page 4-11.
- **Radial grounding conductors** for high lightning prone geographical areas, sites that are normally occupied (such as 911 dispatch centers), sites with high soil resistivity, or when bedrock prohibits the driving of ground rods. See “Radial (Counterpoise) Grounding Conductors” on page 4-24.
- **Proper bonding of all grounding electrode system components.** See “Bonding to the External Grounding (Earthing) Electrode System” on page 4-40.
- **Proper bonding of all ancillary equipment.** See “Bonding to the External Grounding (Earthing) Electrode System” on page 4-40.

The grounding electrode system resistance requirement is determined based on the classification of the site. Communications sites are classified by this standard into two categories:

- **Type A:** See “Type “A” Sites - Light Duty” on page 4-46.
- **Type B:** See “Type “B” Sites - Standard Duty” on page 4-47.

4.7.4.1 TYPE “A” SITES - LIGHT DUTY

Type “A” sites **shall** have a grounding (earthing) electrode system resistance design goal of 25 ohms or less for a single grounding electrode (NFPA 70-2005, Article 250.56; MIL-HDBK-419A, section 2.2.2.1). If the design goal of 25 ohms cannot be achieved throughout the year with a single grounding electrode, then the grounding electrode **shall** be augmented by at least one additional grounding electrode (NFPA 70-2005, Article 250.56). See “Soil Resistivity Variability and Factors Affecting Soil Resistivity” on page B-1 for information regarding the seasonal variations in grounding electrode resistance.

NOTE: It is recommended to use two grounding electrodes as the minimum installation, even if 25 ohms is achieved with a single grounding electrode.

Type “A” sites typically have the following characteristics:

- No tower associated with the site
- Non-critical installation
- Not part of a larger system infrastructure
- Single control station
- RF alarm/reporting site
- Small telemetry cabinet utilizing an existing utility pole to support the antenna
- Single voting receiver site
- May be located in a commercial office or residence

4.7.4.2 TYPE “B” SITES - STANDARD DUTY

Type “B” sites **shall** have a grounding (earthing) electrode system resistance design goal as low as practical and not over 10 ohms (AS 3516.2-1998, BS 6651:1999, FAA STD 019d-2002, MIL-HDBK-419A, and MIL-STD-188-124A); Motorola recommends a design goal of 5 ohms or less (also see the International Association of Electrical Inspectors publication, “Soares Book on Grounding and Bonding” - 9th Edition, Appendix B and the United States National Weather Service Manual 30-4106-2004, “Lightning Protection, Grounding, Bonding, Shielding, and Surge Protection Requirements”). If the design goal of 10 ohms (or recommended 5 ohms) cannot be achieved with the minimum accepted grounding electrode system, reasonable efforts **shall** be made to achieve the design goal using supplemental grounding techniques. The supplemental grounding techniques are described in “Supplemental Grounding (Earthing)” on page 4-48.

Type “B” sites typically have the following characteristics:

- A tower is associated with the site
- 911 dispatch center
- Communications dispatch center
- Base station and/or repeater site
- Telecommunication repeater equipment is installed, such as cellular, PCS, or wide-area repeater site
- Large installation or multiple systems, such as telephone or electronic switches, LANs/WANs, and Mobile Switching Offices (MSO) are installed
- Critical public safety or military installation

4.7.4.3 SUPPLEMENTAL GROUNDING (EARTHING)

Sites with high (poor) soil resistivity **shall** require enhancements to the grounding (earthing) electrode system if the resistance requirement of the site cannot be met. Sites in high lightning prone geographical areas, and sites normally occupied (such as dispatch centers), should also include enhancements to the grounding electrode system, regardless if the resistance requirements are met. Some techniques for enhancing the grounding electrode system are described below:

- Installation of radial grounding conductors.
- Installation of concrete encased electrodes in new construction.
- Installation of longer ground rods.

NOTE: Doubling the length of a ground rod will reduce its resistance value by approximately 40% (assuming homogeneous soil).

- Installation of electrolytic ground rods.
- Use of grounding electrode encasement materials.
- Specific design by Motorola Engineering or other engineering firm.

4.7.5 TYPE “A” SITE GROUNDING (EARTHING)

In sites defined as Type “A”, a single ground rod may be sufficient if it can achieve 25 ohms or less throughout the year. If a single ground rod cannot achieve 25 ohms or less throughout the year, then the grounding (earthing) electrode **shall** be augmented by an additional grounding electrode (NFPA 70-2005, Article 250.56 and MIL-HDBK-419A, section 2.2.2.1), or alternate methods **shall** be used. Such alternate methods may include the following:

- Installation of concrete encased electrodes as part of new construction.
- Installation of a longer rod that can achieve 25 ohms or less throughout the year. In general, doubling the length of a ground rod will reduce its resistance value by approximately 40%.
- Installation of a parallel ground rod. The ground rods **shall** maintain a minimum separation of 1.8 m (6 ft.) from one another (NFPA 70-2005, Article 250.56). For maximum parallel efficiency, the ground rods should be separated by the sum of their respective lengths. See “Grounding (Earthing) Electrode Resistance Characteristics and Sphere of Influence” on page 4-9 and Figure 4-31 for additional information.

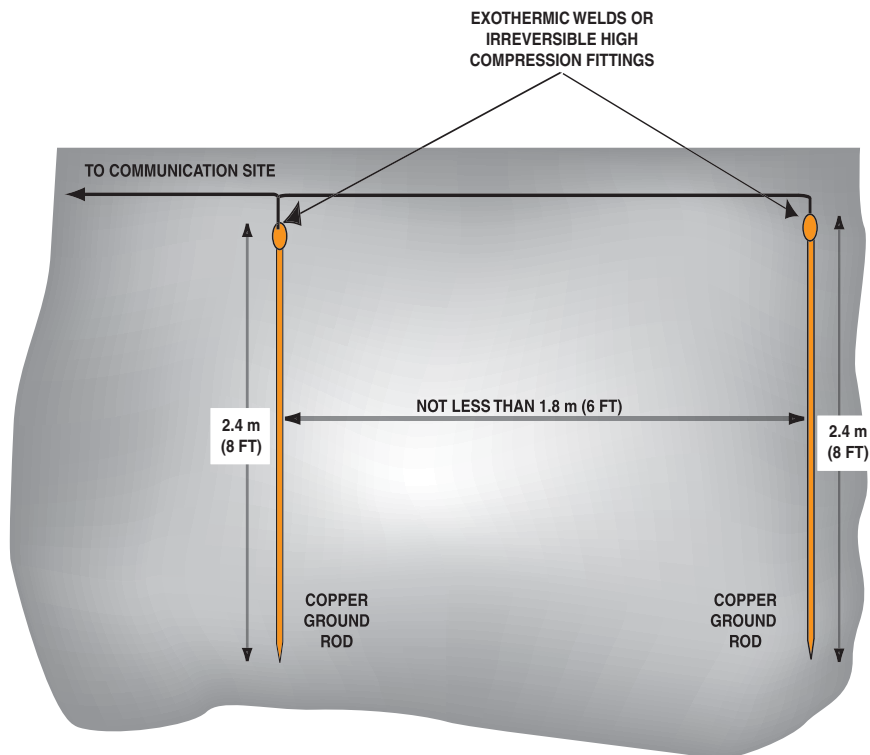

FIGURE 4-31 PARALLEL GROUND ROD INSTALLATION

NOTE: It is recommended to use two grounding electrodes as the minimum installation, even if 25 ohms is achieved with a single grounding electrode.

- Installation of a small ground ring (Figure 4-64 on page 4-89).
- Installation of an electrolytic ground rod.

At an existing building, the AC power system grounding electrode system will typically serve adequately as the communications Type “A” grounding electrode system. A supplemental Type “A” grounding electrode system may need to be installed if the site has an RF transmission line (or other communications cables) entry point at a different location than the AC power utilities entrance. If a supplemental Type “A” grounding electrode system is installed, it **shall** be bonded to any other grounding electrode system at the site. See “Common Grounding (Earthing)” on page 4-5. For an example of bonding a supplemental grounding electrode system to an existing AC power service grounding electrode system, see Figure 4-54 on page 4-77 and Figure 4-64 on page 4-89.

NOTE: A single 2.4 m × 15.9 mm (8 ft. × 0.625 in.) ground rod requires a soil resistivity of approximately 6,250 ohm-cm or less throughout the year in order to achieve a resistance value of 25 ohms; a 3 m × 15.9 mm (10 ft. × 0.625 in.) ground rod would require 7,500 ohm-cm; a 4.9 m × 15.9 mm (16 ft. × 0.625 in.) ground rod would require 11,200 ohm-cm; and a 6.1 m × 15.9 mm (20 ft. × 0.625 in.) ground rod would require 13,600 ohm-cm. See Chapter, “Soil Resistivity Measurements,” for additional information.

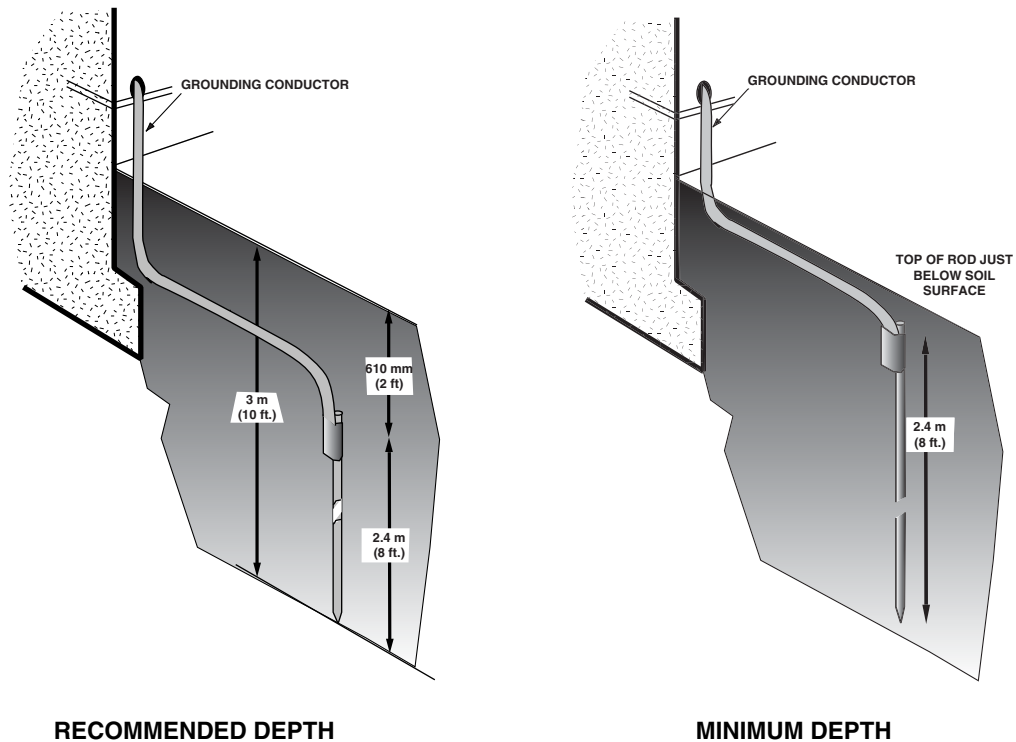

FIGURE 4-32 TYPICAL SINGLE GROUNDING ELECTRODE INSTALLATION

4.7.6 TOWER GROUNDING (EARTHING)

An external grounding (earthing) electrode system for a communications tower is required to disperse lightning energy to earth before it is able to enter the associated communications structure (or enclosure). Although it is impossible to prevent all lightning energy from entering the communications structure (or enclosure), the majority of the lightning energy can be controlled and diverted to earth (ANSI T1.313-2003 and ANSI T1.334-2002). Antenna masts and metal support structures **shall** be grounded (NFPA 70-2005, Article 810.15).

IMPORTANT: For towers installed at high lightning prone geographical areas or sites normally occupied (such as 911 dispatch centers), radial grounding conductors should be employed to improve equalization of the grounding electrode system (ANSI T1.334-2002, section 5.4). See “Radial (Counterpoise) Grounding Conductors” on page 4-24. This is recommended even if the grounding electrode system resistance requirement is met without the use of radial grounding conductors.

Towers can be classified into three basic categories (ANSI T1.334-2002, section 6.3):

- Self-Supporting Towers (including monopoles)
- Guyed Towers
- Wooden Structures (poles)

**CAUTION**

Some antenna structures, such as water storage tanks, may require special grounding and bonding techniques due to the possibility of corrosion and should be designed by a licensed engineer.

IMPORTANT: When only the minimum number of tower ground rods are used, the ground rods **shall** be separated from other ground rods by the sum of their respective lengths, whenever practical. When the tower ground ring is large enough, additional ground rods **shall** be installed as needed to limit the distance between 2.4 m (8 ft.) ground rods from 3 m to 4.6 m (10 to 15 ft.) (ANSI T1.334-2002); if longer ground rods are used, a larger separation proportional to the increase in rod length may be used. See “Grounding (Earthing) Electrode Resistance Characteristics and Sphere of Influence” on page 4-9 for additional information.

4.7.6.1 SELF-SUPPORTING TOWERS (INCLUDING MONOPOLES)

Self-supporting towers **shall** minimally be grounded (earthed) as follows:

- The tower **shall** be encircled by a ground ring (ANSI T1.334-2002, section 5 and MIL-HDBK-419A).
 - The tower ground ring **shall** be installed at least 610 mm (2 ft.) from the tower structure base or footing (ANSI T1.334-2002, section 5.3.1).
 - The tower ground ring **shall** be installed in accordance with “External Building and Tower Ground Ring” on page 4-22.
 - The tower ground ring **shall** be bonded to the building ground ring in at least two points using a 35 mm² csa (#2 AWG) or coarser, bare, solid, tinned or un-tinned, copper conductor (ANSI T1.334-2002, figure 1 and MIL-STD-188-124B). See “External Building and Tower Ground Ring” on page 4-22 and Figure 4-18 on page 4-23.
- For towers not exceeding 1.5 m (5 ft.) in base width (including monopoles), the tower ground ring **shall** consist of at least two ground rods installed on opposite (diametrically opposed) sides (ANSI T1.313-2003, section 10.3.1; ANSI T1.334-2002, section 5.2; and ANSI/TIA/EIA-222-F-R2003, section 12).
 - Ground rods **shall** meet the specifications and be installed in accordance with “Ground Rods” on page 4-11.
- For towers equal to or exceeding 1.5 m (5 ft.) in base width, the tower ground ring **shall** consist of at least one ground rod per tower structure leg (ANSI T1.313-2003, section 10.3.1; and ANSI/TIA/EIA-222-F-R2003, section 12).
 - Ground rods **shall** meet the specifications and be installed in accordance with “Ground Rods” on page 4-11.
- For monopole towers equal to or exceeding 1.5 m (5 ft.) in base width, the tower ground ring **shall** consist of four equally spaced ground rods.
 - Ground rods **shall** meet the specifications of and be installed in accordance with “Ground Rods” on page 4-11.
- All monopole towers **shall** be bonded to the tower ground ring using at least four equally spaced grounding conductors of 35 mm² csa (#2 AWG) or coarser, bare, solid, tinned, copper conductor.

- Each leg of a self-supporting tower **shall** be bonded to the tower ground ring using grounding conductors of 35 mm² csa (#2 AWG) or coarser, bare, solid, tinned, copper conductor. See Figure 4-33.
- The tower grounding conductors **shall** be exothermically bonded to the tower unless specifically directed otherwise by the tower manufacturer.
- The tower's support piers (concrete footings) should have the rebar electrically connected to the tower holding bolts (ANSI T1.313-2003, section 10.3.1).
- Install radial grounding conductors if needed. See “Radial (Counterpoise) Grounding Conductors” on page 4-24.

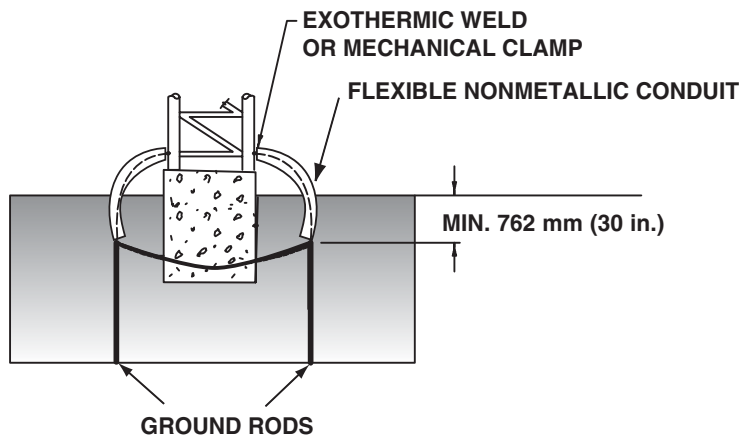

FIGURE 4-33 EXAMPLE OF SELF-SUPPORTING TOWER GROUNDING

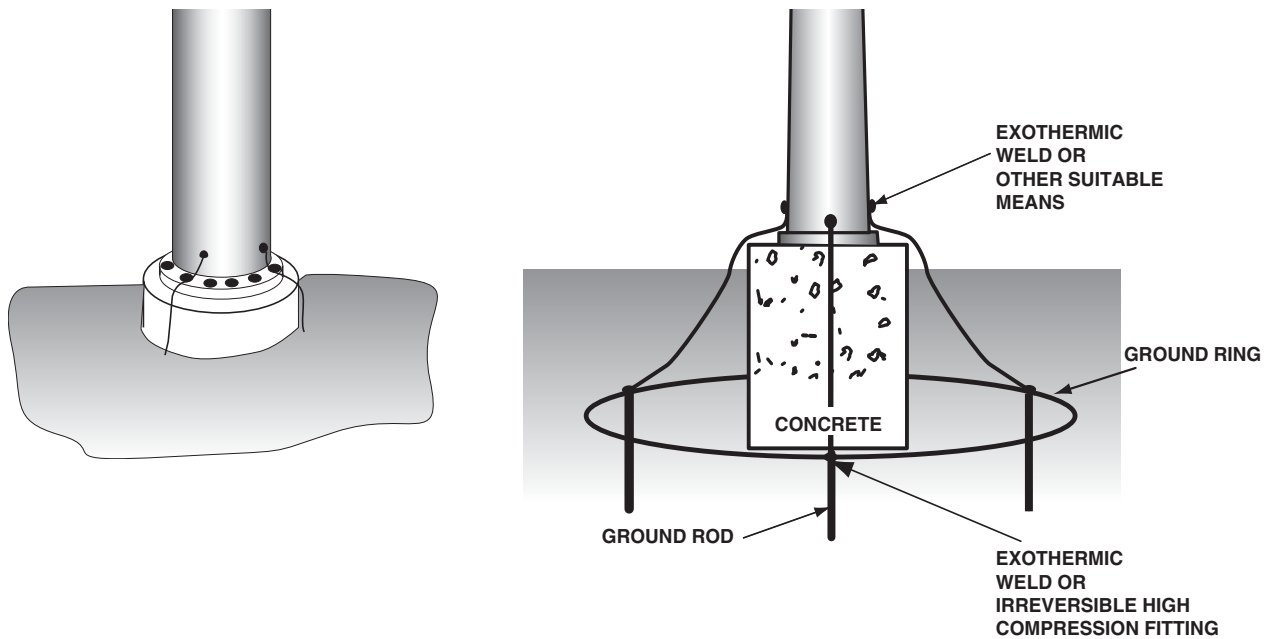

FIGURE 4-34 EXAMPLE OF MONOPOLE TOWER GROUNDING

4.7.6.2 GUYED TOWERS

Guyed towers **shall** minimally be grounded (earthed) as follows:

- The tower **shall** be encircled by a ground ring (ANSI T1.334-2002, section 5 and MIL-HDBK-419A).
 - The tower ground ring **shall** be installed at least 610 mm (2 ft.) from the tower structure base or footing (ANSI T1.334-2002, section 5.3.1).
 - The tower ground ring **shall** be installed in accordance with “External Building and Tower Ground Ring” on page 4-22.
 - The tower ground ring **shall** be bonded to the building ground ring in at least two points using a 35 mm² csa (#2 AWG) or coarser, bare, solid, tinned or un-tinned, copper conductor (ANSI T1.334-2002, figure 1, and MIL-STD-188-124B). See “External Building and Tower Ground Ring” on page 4-22.
- The tower ground ring **shall** consist of at least two ground rods installed on opposite (diametrically opposed) sides (ANSI T1.313-2003, section 10.3.1; ANSI T1.334-2002, section 5.2; and ANSI/TIA/EIA-222-F-R2003, section 12).
 - Ground rods **shall** meet the specifications and be installed in accordance with “Ground Rods” on page 4-11.
- The bottom plate of a guyed tower **shall** be bonded to the tower ground ring using three equally spaced grounding conductors, or each leg **shall** be bonded to the tower ground ring using grounding conductors of 35 mm² csa (#2 AWG) or coarser, bare, solid, tinned copper conductor. See Figure 4-35.
- The tower grounding conductors **shall** be exothermically bonded to the tower unless specifically directed otherwise by the tower manufacturer.
- The tower's support piers (concrete footings) should have the rebar electrically connected to the tower holding bolts (ANSI T1.313-2003, section 10.3.1).
- Install radial grounding conductors if needed. See “Radial (Counterpoise) Grounding Conductors” on page 4-24.

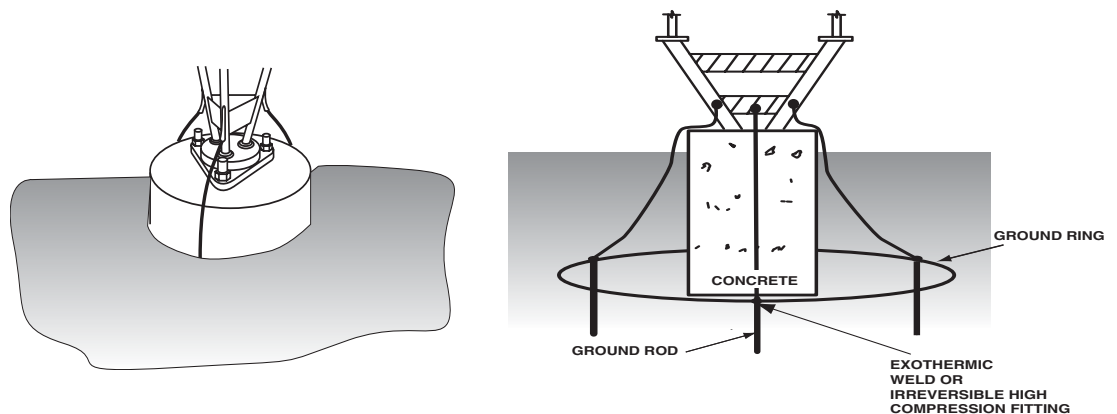

FIGURE 4-35 EXAMPLE OF GUYED TOWER GROUNDING

4.7.6.2.1 GUY ANCHOR POINTS

Grounding (earthing) guy anchor points requires special attention due to the possibility of galvanic corrosion damage to the anchor points. Although various methods for grounding guy anchor points are possible, any variation from the requirements and guidelines in this section **shall** be designed by a licensed professional engineer. Guy wire anchors **shall** minimally be grounded as outlined in the following sections.

New Construction:

- The guy anchor **shall not** be permitted to make direct contact with soil by being encased in reinforced concrete over the entire embedded length of the anchor. The concrete encasement **shall** extend a minimum of 152 mm (6 in.) above grade.

NOTE: Encasing the anchor in reinforced concrete over the entire embedded length of the anchor helps prevent galvanic corrosion from the guy anchor to copper components of the grounding electrode system. Galvanized steel encased in concrete has a similar potential to that of copper (see “Miscellaneous General Information” on page 4-38). Additionally, encasing the anchor in reinforced concrete over the entire embedded length of the anchor will help prevent the galvanic corrosion that would otherwise exist from the portion of the anchor in direct contact with soil to the portion encased in concrete.

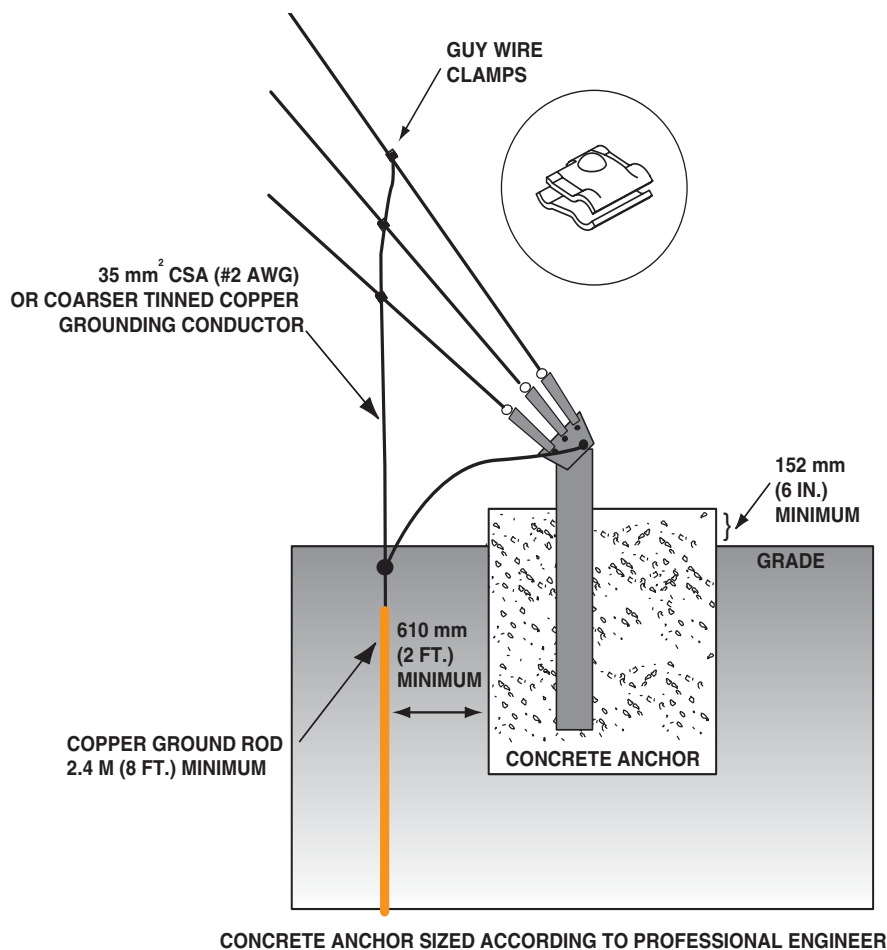

FIGURE 4-36 GUY ANCHOR POINT GROUNDING FOR NEW CONSTRUCTION

- A ground rod **shall** be installed at each guy anchor point (ANSI/TIA/EIA-222-F-R2003). Ground rods **shall** meet the specifications and be installed in accordance with “Ground Rods” on page 4-11.
- All guy wires at a guy anchor point **shall** bond to the ground rod (ANSI T1.313-2003, section 10.3.1, and ANSI/TIA/EIA-222-F-R2003) using a grounding conductor of 35 mm² csa (#2 AWG) or coarser, bare, solid, tinned, copper conductor. Do not use un-tinned wire.
- The grounding conductor **shall** be connected to each guy wire using stainless steel or other approved clamps. Each connection **shall** be coated with a listed conductive anti-oxidant compound.

**CAUTION****Do not attempt to exothermically weld to tower guy wires.**

- The grounding conductor **shall** be connected to the guy wires above the turnbuckles.
- The grounding conductor **shall** maintain a continuous vertical drop from the guy wire attachment point to the grounding electrode.

Existing Anchor Points:

- If possible, backfill around the embedded anchor with a high resistivity soil, such as gravel. This may be beneficial in reducing the rate of corrosion between the guy anchor point and copper grounding electrode system components. (TIA/EIA-222-F-R2003)
- Isolation of anchors from the structure using guy insulators may help reduce the transmission of stray currents from outside sources, therefore, minimizing electrolytic corrosion (TIA/EIA-222-F-R2003, section 4.1). Guy isolators should only be installed under the advice of a professional engineer. Galvanic corrosion due to the presence of copper ground rods is greatly reduced if the ground wires are connected on the tower side of the isolation point (TIA/EIA-222-F-R2003, section 4.1).
- A ground rod **shall** be installed at each guy anchor point (ANSI/TIA/EIA-222-F-R2003). Ground rods **shall** meet the specifications and be installed in accordance with “Ground Rods” on page 4-11. In order to reduce galvanic corrosion from the galvanized guy anchor point to a nearby copper ground rod, this ground rod **shall** be constructed of galvanized steel, unless a guy insulator is used (TIA/EIA-222-F-R2003, section 4.1).

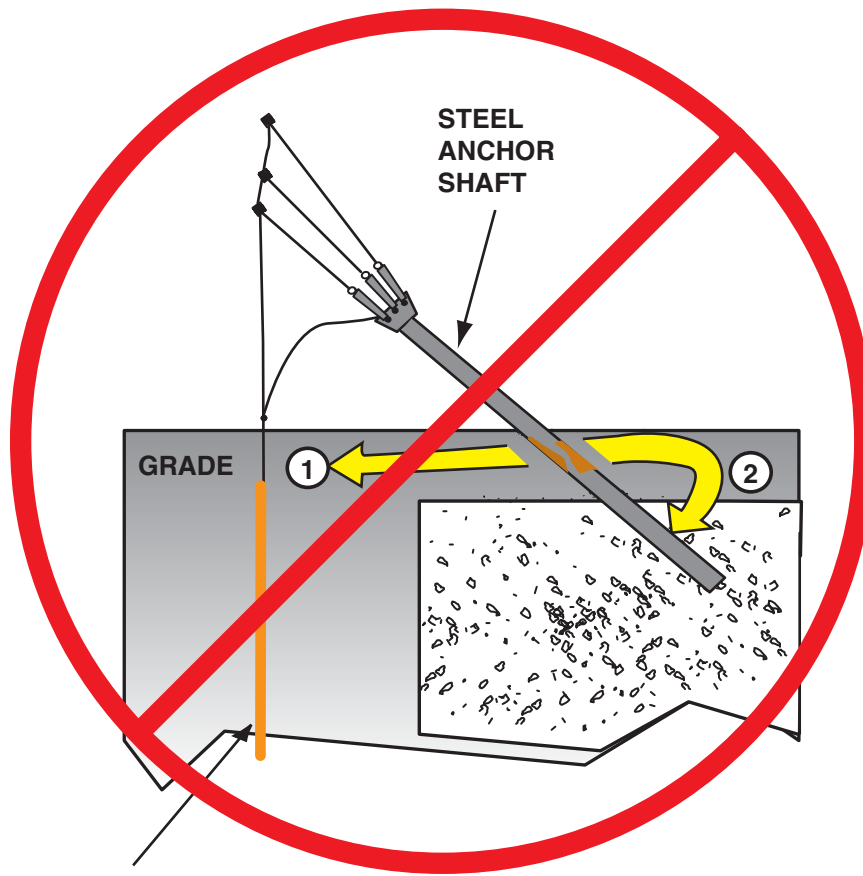

COPPER GROUND ROD

1. CORROSION FROM STEEL ANCHOR SHAFT TO COPPER GROUND ROD AND OTHER COPPER GROUNDING ELECTRODE SYSTEM COMPONENTS
2. CORROSION FROM STEEL ANCHOR SHAFT TO THE PORTION OF ANCHOR SHAFT ENCASED IN CONCRETE (STEEL ENCASED IN CONCRETE IS SIMILAR TO COPPER.)

FIGURE 4-37 GUY ANCHOR GALVANIC CORROSION EXAMPLE

- All guy wires at a guy anchor point **shall** bond to the ground rod (ANSI T1.313-2003, section 10.3.1, and ANSI/TIA/EIA-222-F-R2003) using a grounding conductor of 35 mm² csa (#2 AWG) or coarser, bare, solid, tinned copper conductor. Do not use un-tinned wire.
- The grounding conductor **shall** be connected to each guy wire using stainless steel or other approved clamps. Each connection **shall** be coated with a listed conductive anti-oxidant compound.

CAUTION

Do not attempt to exothermically weld to tower guy wires.

- The grounding conductor **shall** be connected to the guy wires above the turnbuckles (see Figure 4-38).
- The grounding conductor **shall** maintain a continuous vertical drop from the guy wire attachment point to the grounding electrode.

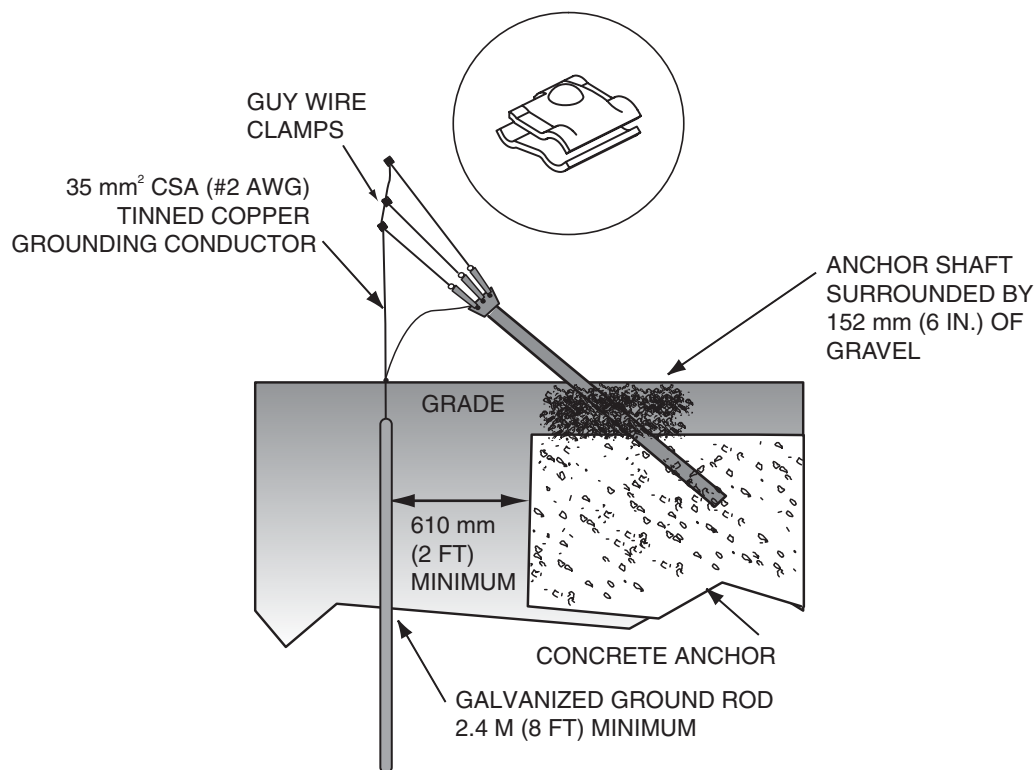

FIGURE 4-38 GUY ANCHOR POINT GROUNDING FOR EXISTING CONSTRUCTION

4.7.6.2.2 CATHODIC PROTECTION

Additional corrosion control can be obtained through the use of Cathodic Protection. See MIL-HDBK-419A Volume I, section 2.10 and TIA/EIA-222-F-R2003, section 4.4 for additional information. Cathodic protection should only be installed under the advice of a licensed professional engineer.

WARNING

Any type of corrosion control installation techniques does not eliminate the need for proper monitoring and maintenance over the life of the structure (TIA/EIA-222-F-R2003, section 4).

4.7.6.3 WOODEN STRUCTURES (POLES)

Wooden pole structure towers (and other non-metallic towers) **shall** minimally be grounded (earthed) as follows:

- The wooden pole **shall** have a vertical grounding conductor installed over the length of the wooden pole.
- The vertical grounding conductor **shall** be constructed of 35 mm² csa (#2 AWG) or coarser solid, bare, tinned or un-tinned copper conductor (ANSI T1.334-2002, section 6.5).
- The grounding conductor **shall** be installed in accordance with “Grounding (Earthing) Conductors” on page 4-28.
- The vertical grounding conductor **shall** terminate into a radial grounding conductor or tower ground ring (with rods) (ANSI T1.334-2002, section 6.5).
 - The radial grounding conductor **shall** be installed in accordance with “Radial (Counterpoise) Grounding Conductors” on page 4-24.
 - The tower ground ring **shall** be installed in accordance with “External Building and Tower Ground Ring” on page 4-22.
 - Ground rods **shall** meet the specifications and be installed in accordance with “Ground Rods” on page 4-11.
- The wooden pole grounding electrode system **shall** be bonded to the building grounding electrode system. See “Common Grounding (Earthing)” on page 4-5.

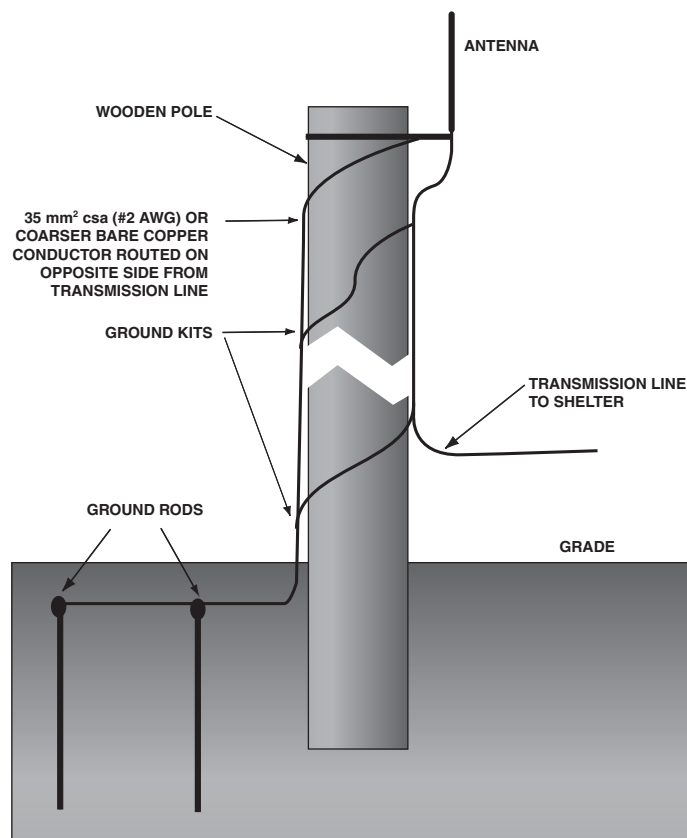

FIGURE 4-39 WOODEN POLE GROUNDING

4.7.7 DEDICATED COMMUNICATIONS BUILDING GROUNDING (EARTHING)

All dedicated communications buildings **shall** have a properly installed external grounding (earthing) electrode system. The grounding electrode system resistance **shall** meet the requirements of “Grounding (Earthing) Electrode System Resistance Requirements” on page 4-46.

A typical site grounding electrode system layout is shown in Figure 4-4 on page 4-8. The building grounding electrode system requirements are listed below and **shall** also include any additional grounding electrode system components required to achieve the resistance requirements of the site. See “Minimum Site Grounding (Earthing) Requirements” on page 4-44.

- Installation of concrete encased electrodes as part of new construction. See “Concrete-Encased Electrodes” on page 4-20.
- The building **shall** be encircled by a ground ring installed in accordance with “External Building and Tower Ground Ring” on page 4-22.
- The building ground ring **shall** have a ground rod installed near the external ground bus bar (EGB), at each corner of the shelter, and as follows:
 - If 2.4 m (8 ft.) ground rods are used, additional ground rods **shall** be installed as needed to reduce the distance between rods from 3 m to 4.6 m (10 to 15 ft.) (ANSI T1.334-2002).
 - If longer ground rods are used, a larger separation proportional to the increase in rod length may be used.
 - Ground rods **shall** be placed a minimum of one rod length apart along the ground rings (ANSI T1.313-2003, figure 3(a)).
 - Ground rods **shall not** be separated from an adjacent ground rod along the ground ring by more than the sum of their respective lengths. (MIL-HDBK-419A).
- The ground rods **shall** be installed in accordance with “Ground Rods” on page 4-11.
- The ground rods **shall** be exothermically welded to the ground ring, or as otherwise allowed in “Bonding to the External Grounding (Earthing) Electrode System” on page 4-40.
- The building ground ring **shall** be bonded to the tower ground ring using a minimum of two 35 mm² csa (#2 AWG) or coarser, bare, solid, tinned or un-tinned, copper conductors. See “External Building and Tower Ground Ring” on page 4-22 and Figure 4-4 on page 4-8.
- The tower **shall** be grounded in accordance with “Tower Grounding (Earthing)” on page 4-50.
- Determine if radial grounding conductors should be installed at the site, see “Radial (Counterpoise) Grounding Conductors” on page 4-24

4.7.7.1 GENERATORS EXTERNAL TO THE BUILDING

Generators installed outside of the building, within 1.8 m (6 ft.) of the building, **shall** be bonded to the nearest practical location on the grounding (earthing) electrode system as shown in Figure 4-40 on page 4-60, using a 16 mm² csa (#6 AWG) or coarser, copper conductor (ANSI T1.334-2002, section 5.3.3). Grounding conductors routed below ground, or partially below ground, **shall** be a 35 mm² csa (#2 AWG) or coarser, bare, solid, tinned or un-tinned, copper conductor.

External generator grounding **shall** comply with the following:

- Bonding to the generator chassis **shall** be done in accordance with the manufacturer's requirements.

- The grounding conductors **shall** meet the requirements of “Grounding (Earthing) Conductors” on page 4-28.
- Bonding to the grounding electrode system **shall** be made using exothermic welding or listed irreversible high compression fittings. See “Bonding to the External Grounding (Earthing) Electrode System” on page 4-40.

Generators installed more than 1.8 m (6 ft.) away from the building **shall** be bonded to the nearest practical location on the grounding electrode system as describe above for generators within 1.8 m (6ft.) of the building. In addition, the generator **shall** have a ground rod installed nearby and bonded to the generator (ANSI T1.313-2003). See Figure 4-40. Installation of the addition generator ground rod **shall** comply with the following:

- The additional ground rod **shall** meet the requirements of “Ground Rods” on page 4-11.
- The additional ground rod **shall** be installed using methods described in “Ground Rods” on page 4-11.
- The grounding conductor between the ground rod and generator **shall** be a 35 mm² csa (#2 AWG) or coarser, bare, solid, tinned or un-tinned, copper conductor. The grounding conductor **shall** meet the requirements of “Grounding (Earthing) Conductors” on page 4-28.
- Bonding to the ground rod **shall** be made using exothermic welding or listed irreversible high compression fittings. See “Bonding to the External Grounding (Earthing) Electrode System” on page 4-40.

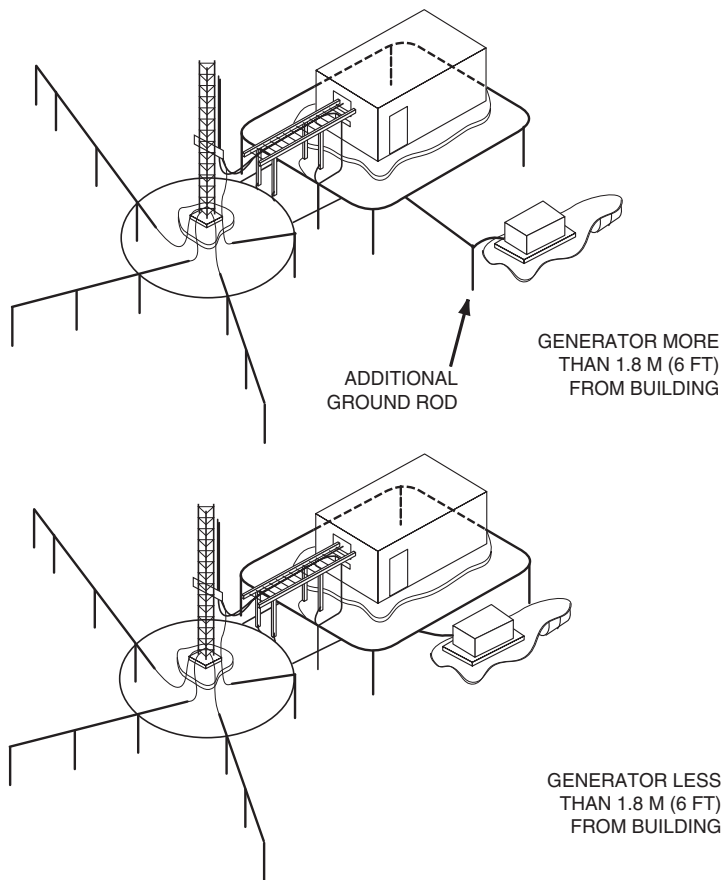

FIGURE 4-40 GENERATOR GROUNDING

4.7.8 OUTDOOR CABINET GROUNDING (EARTHING)

Outdoor cabinets are grounded (earthed) in a very similar manner as a dedicated communications building (ANSI T1.313-2003, section 1.1). See “Dedicated Communications Building Grounding (Earthing)” on page 4-59 for details.

Outdoor cabinets **shall** be grounded as follows:

- The cabinet **shall** be encircled with a ground ring. The ground ring **shall** meet the requirements defined in “External Building and Tower Ground Ring” on page 4-22.
- The ground ring **shall** be installed at least 610 mm (2 ft.) from the cabinet foundation/pad.
- The cabinet ground ring **shall** have a ground rod installed at each corner and as needed to limit the distance between rods from 3 m to 4.6 m (10 to 15 ft.). Ground rods **shall** have a minimum separation from other ground rods equal to its length (ANSI T1.313-2003).
- The cabinet ground ring **shall** bond to the tower ground ring as detailed in “External Building and Tower Ground Ring” on page 4-22.
- Towers associated with outdoor cabinets **shall** be grounded as detailed in “Tower Grounding (Earthing)” on page 4-50.
- RF transmission lines **shall** be grounded/bonded as detailed in “RF Transmission Line and Preamplifier Grounding (Earthing)” on page 4-62.
- Metallic objects near the cabinet **shall** be bonded to the cabinet grounding electrode system as detailed in “Metallic Objects Requiring Bonding” on page 4-67.
- The cabinet grounding electrode system **shall** bond to the cabinet's internal ground point and cabinet housing using a 35 mm² csa (#2 AWG) or coarser, tinned or un-tinned, copper conductor. The conductor **shall** be run in a direct manner with no sharp bends or narrow loops (ANSI T1.313-2003, section 11.3, and ANSI T1.334-2002, section 13.4). See “Bending And Routing Grounding (Earthing) Conductors” on page 4-29.

In addition to the above requirements, the follow recommendations should be considered:

- Cabinets installed on pads that incorporate a footing should consider the use of concrete encased electrodes, in addition to the ground ring. See “Concrete-Encased Electrodes” on page 4-20.
- Depending on the location of the cabinet's internal ground point, the grounding conductor installed between the grounding electrode system and the cabinet's internal ground point may need to be routed through the concrete footing/pad in order to allow conductor routing in a direct manner. This requires the grounding conductor to be installed before the concrete is poured.

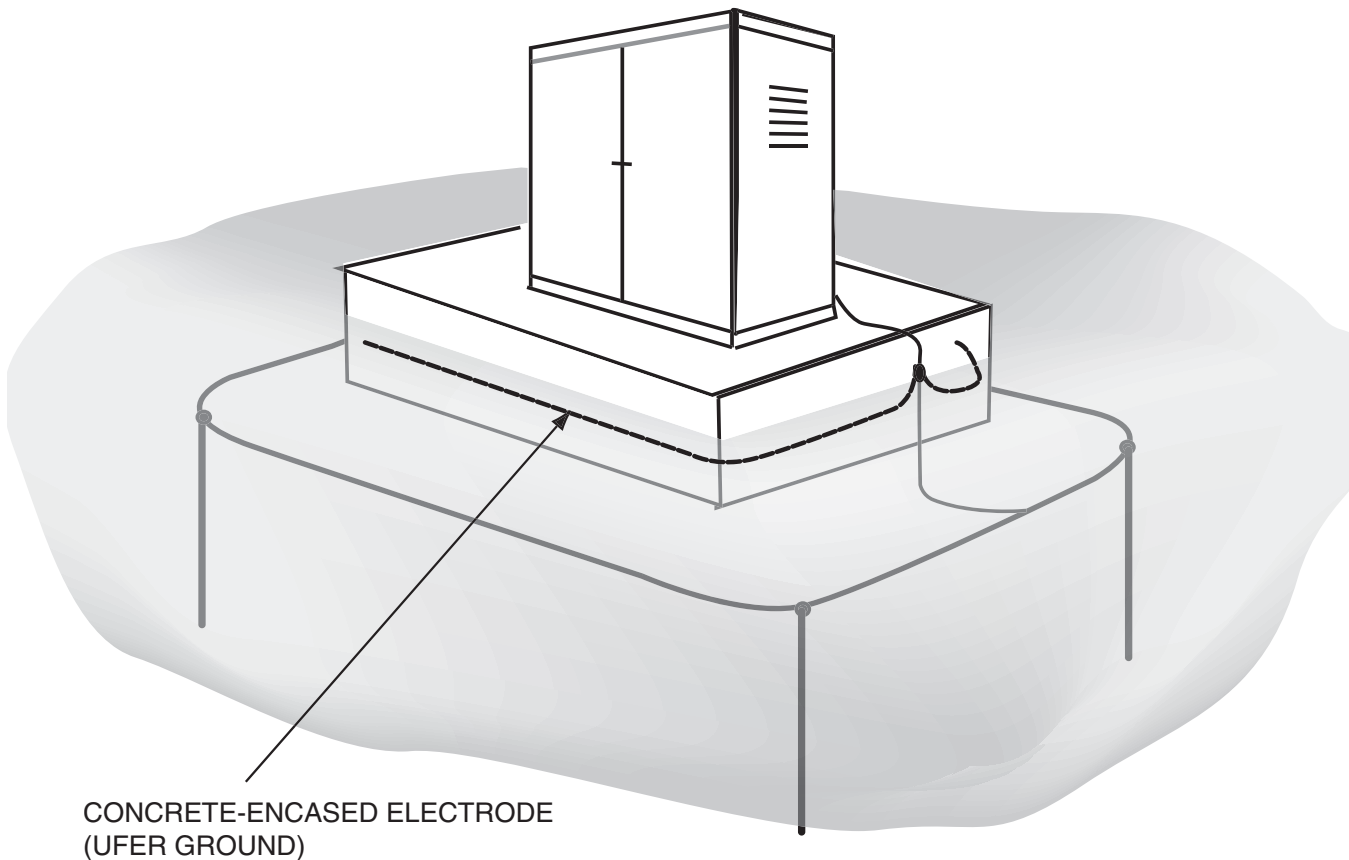

CONCRETE-ENCASED ELECTRODE
(UFER GROUND)

FIGURE 4-41 CABINET GROUNDING SYSTEM

4.7.9 RF TRANSMISSION LINE AND PREAMPLIFIER GROUNDING (EARTHING)

Tower mounted antenna preamplifiers **shall** be bonded to the tower using 16 mm² csa (#6 AWG) or coarser, solid or stranded, tinned, copper conductor. Connection to the amplifier **shall** be made in accordance with the amplifier manufacturer requirements. Connection to the tower **shall** be made using tower manufacturer-approved methods (typically a type of mechanical clamp).

Transmission lines **shall** be bonded to the tower in order to prevent lightning from creating a difference of potential between the tower and the transmission lines and to help drain lightning energy to earth. A potential difference could cause arcing between the tower and the RF transmission line cable, resulting in damage to the transmission lines. See Figure 4-43 through Figure 4-46 for examples of transmission line grounding (earthing) conductor attachment methods.

All transmission lines **shall** be bonded to the tower using ground kits as follows:

- Transmission line ground kits **shall** be installed per manufacturer specifications.
- Transmission line ground kits **shall** be sealed from the weather to prevent water and corrosion damage to the transmission line (ANSI T1.313-2003, section 10.5).

- Transmission line ground kits **shall** be attached to an effectively grounded vertical member of the tower, using tower manufacturer-approved methods (typically a type of mechanical clamp). Transmission line ground kits may attach to a tower bus bar in lieu of directly attaching to the tower structure, see “Tower Ground Bus Bar” on page 4-32. See Figure 4-42 through Figure 4-46 for examples of methods used to attach to the tower. (ANSI T1.313-2003, section 10.5)
- Transmission line ground kit grounding conductors **shall** be installed without drip loops, parallel to the transmission line, and pointed down towards the ground to provide a direct discharge path for lightning (ANSI T1.313-2003, section 10.5.1).
- Transmission line ground kits **shall** be installed at the first point of contact, near the antenna (ANSI T1.334-2002, section 6.6; ANSI T1.313-2003, section 10.5.1; and MIL-HDBK-419A).
- Transmission line ground kits **shall** be installed at the bottom of the tower near the vertical to horizontal transition point (ANSI T1.313-2003, section 10.5.1; ANSI T1.334-2002, section 6.6; and MIL-HDBK-419A). The ground kits **shall** be bonded to the tower or tower ground bus bar (TGB) if installed.
- If the tower is greater than 61 m (200 ft.) in height, an additional ground kit **shall** be installed at the tower midpoint (ANSI T1.334-2002, section 6.6 and MIL-HDBK-419A). Additional ground kits **shall** be installed as necessary to reduce the distance between ground kits to 61 m (200 ft.) or less.
- In high lightning prone geographical areas, additional ground kits should be installed at spacing between 15.2 to 22.9 m (50 to 75 ft.) (ANSI T1.313, section 10.5.1 and ANSI T1.334-2002, section 6.6). This is especially important on towers taller than 45.7 m (150 ft.).

NOTE: The use of down-conductors on metallic towers is not recommended for grounding/bonding transmission lines. The down-conductor has a much higher impedance to earth than the tower. The use of down-conductors does not provide equipotential bonding between the transmission lines and tower.

Transmission line ground kits **shall** be installed near the building, shelter, equipment housing, or cabinet entry point (ANSI T1.334-2002, section 6.6; MIL-HDBK-419A; and NFPA 70-2005, Articles 810.20 and 820.93). The ground kits **shall** bond to the external ground bus bar (EGB) if installed, or directly to the grounding electrode system, ensuring a continuous downward flow toward the grounding electrode system is maintained.

NOTE: Transmission lines installed on a wooden pole structure **shall** bond to the wooden pole vertical grounding conductor in the same manner as described above.



CAUTION

Braided grounding conductors shall not be used under any circumstances. Braided conductors corrode easily and become a point for RF interference.

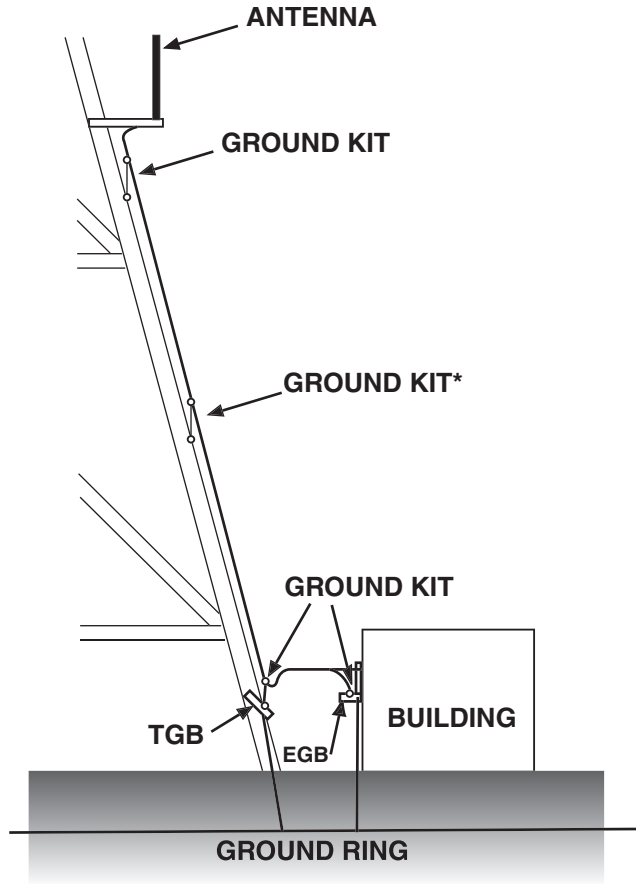

* Required ground kit for towers taller than 61 m (200 ft); optional ground kit for towers 61 m (200 ft) or less.

FIGURE 4-42 LOCATION OF TRANSMISSION LINE GROUNDING KITS

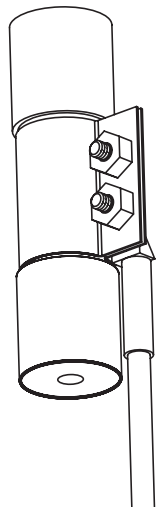

FIGURE 4-43 TRANSMISSION LINE GROUND KIT

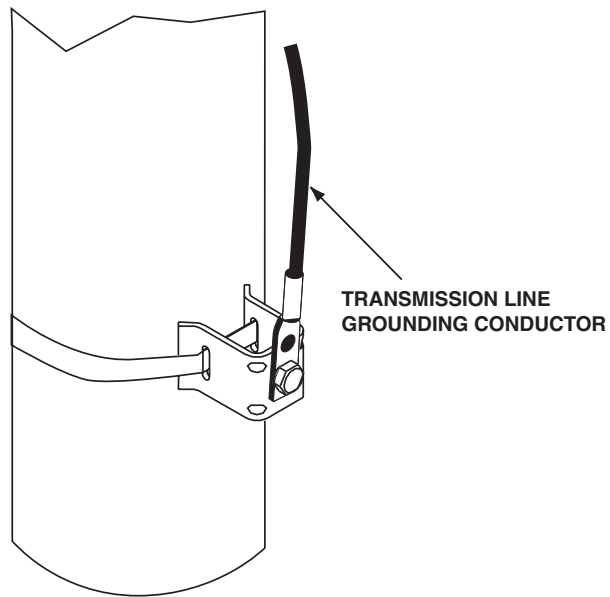

FIGURE 4-44 GROUNDING TRANSMISSION LINE TOP AND MIDDLE (TUBULAR TOWER)

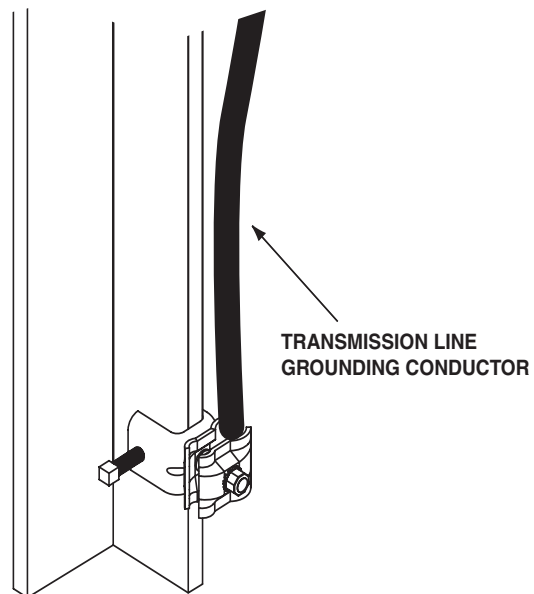

FIGURE 4-45 GROUNDING TRANSMISSION LINE TOP AND MIDDLE (ANGULAR TOWER)

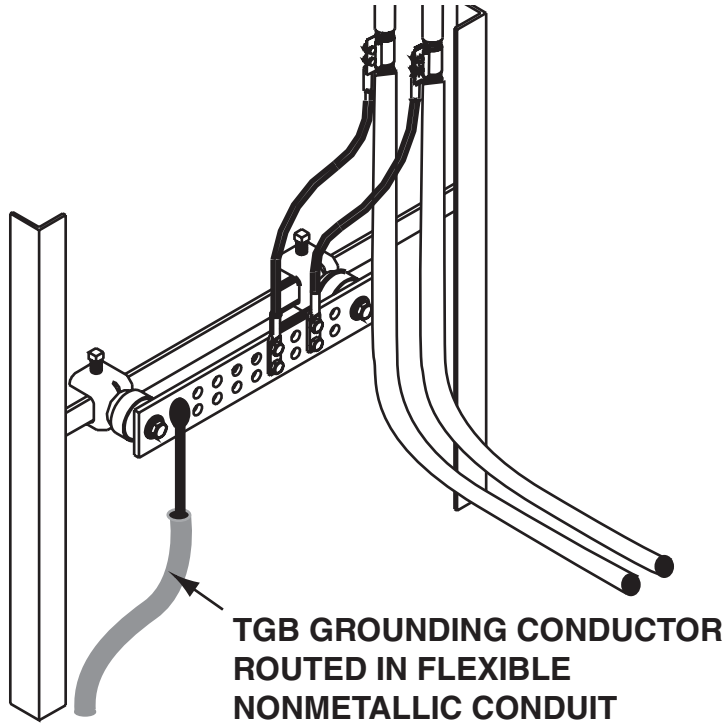

FIGURE 4-46 BUS BAR CONFIGURATION, BOTTOM GROUND KIT (ANGULAR TOWER)

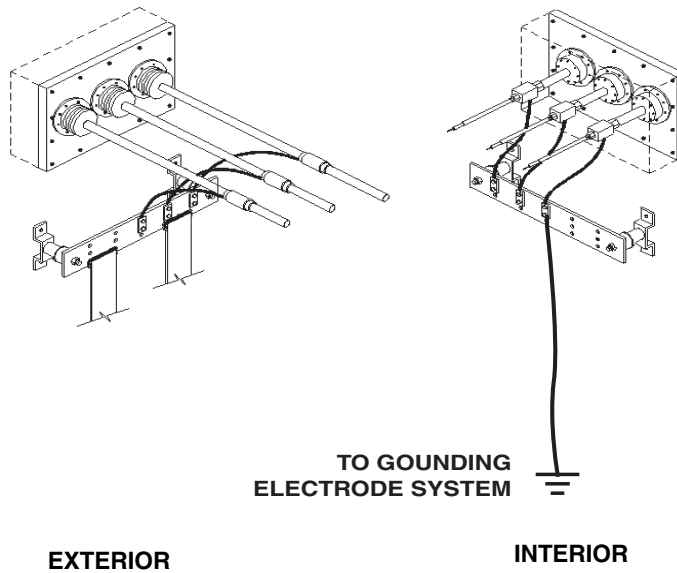

FIGURE 4-47 TRANSMISSION LINE GROUNDING AT BUILDING ENTRY POINT

4.7.10 METALLIC OBJECTS REQUIRING BONDING

The objective of bonding metallic objects is to equalize the potential between conductive parts. This is done for personnel safety and to prevent arcing between metallic components that might otherwise be at different potentials. Bonding conductors **shall** be as short and straight as possible. (ANSI T1.313-2003, section 6.3)

Metallic objects that are located within 1.8 m (6 ft.) of the external grounding (earthing) electrode system, or within 1.8 m (6 ft.) of a grounded metallic item, **shall** be bonded to the external grounding electrode system using 16 mm² csa (#6 AWG) or coarser conductors as described in “Grounding (Earthing) Conductors” on page 4-28 (ANSI T1.334-2002, section 5.3.3). Bonding to the metallic objects **shall** be made as allowed by the manufacturer. In high lightning prone geographical areas, or areas of high soil resistivity, it is recommended to bond all metallic objects that are located within 3 m (10 ft.) of the external grounding electrode system, or within 3 m (10 ft.) of a grounded metallic item (ANSI T1.313-2003, section 10.3.2). Metallic objects requiring bonding include, but are not limited to, the items listed below. (ANSI T1.313-2003, section 10.3.2; ANSI T1.334-2002, section 5.3.3.)

- Fences
- Fence posts
- Fence gates
- Cable Bridge/Ice Bridge
- Generator frame
- Skid plate or metal support frame of a prefabricated shelter
- Metallic members of all incoming telecommunications cables, including paired-conductor and optical fiber (ANSI T1.313-2003, section 8.2)
- Facility grounding electrode system
- Main telephone company ground (if external)
- Metallic entry points
- Metallic conduits, piping, and raceways
- HVAC units
- Vent covers (if not already grounded inside)
- Storage tanks (above and below grade) if allowed
- External light fixtures or support masts
- Any other grounding electrode systems at the site (see “Common Grounding (Earthing)” on page 4-5)

NOTE: Bonding conductors installed underground **shall** be constructed of 35 mm² csa (#2 AWG) or coarser conductor. See “Grounding (Earthing) Conductors” on page 4-28.

Series or daisy chain¹ connection arrangements **shall not** be used. (See Figure 5-20 on page 5-34 for an example of a “daisy-chained” ground connection.)

4.7.10.1 FENCE AND GATE GROUNDING (EARTHING)

All site fencing, including gates, within 1.8 m (6 ft.) of the grounding (earthing) electrode system (such as building or tower ground ring and radial grounding conductors), or any metallic item grounded to the grounding electrode system, **shall** be effectively bonded to the external grounding electrode system to help prevent shock hazard to personnel from lightning or other electrical anomalies (ANSI T1.334-2002, section 5.3.3). In high lightning prone geographical areas, or areas of high soil resistivity, it is recommended to effectively bond fencing that is located within 3 m (10 ft.) of the external grounding electrode system, or within 3 m (10 ft.) of a grounded metallic item (ANSI T1.313-2003, section 10.3.2).

When fences are located at an electrical power substation, the fence grounding **shall** be made as required by local code and by the electric power utility company. The fence grounding should comply with IEEE-STD 80-2000 and is beyond the scope of this document.

A fencing grounding scheme is shown below in Figure 4-48 for a typical communications site with a nearby installed perimeter fence system.

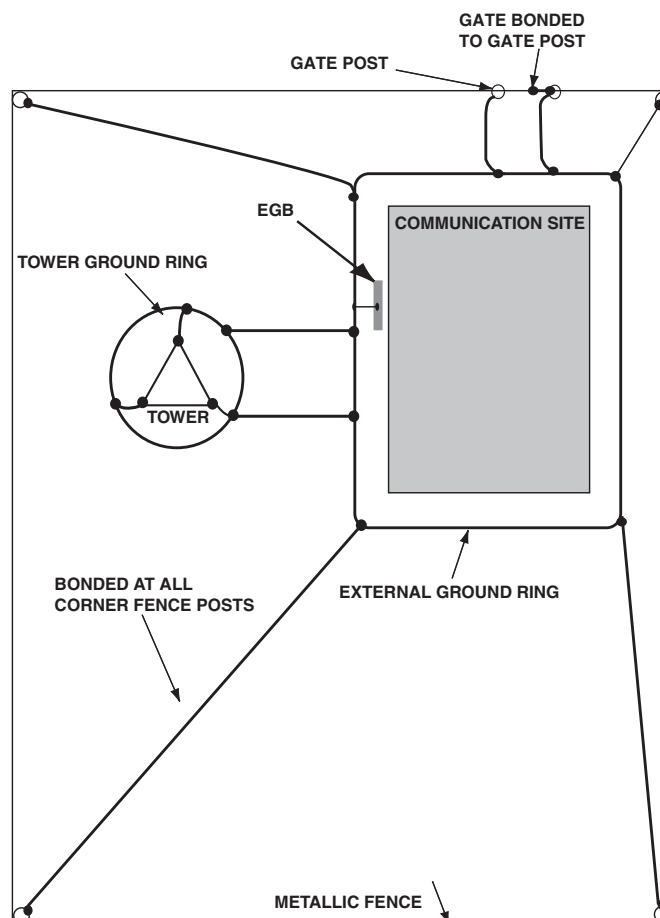

FIGURE 4-48 FENCE BONDING EXAMPLE

1. The series or daisy chain method, which refers to any method of connection whereby the conductors are connected from one peripheral device to a second and possibly on to a third device in a series arrangement whereby the removal of the second connection point interrupts the ground path from the first device, **shall not** be used.

The fencing system for a nearby installed fence at a communications site **shall** be grounded/bonded as follows:

- Each corner fence post **shall** be bonded to the nearest location of the building ground ring using 35 mm² csa (#2 AWG) or coarser, bare, solid or stranded, tinned, copper conductors. The grounding conductors **shall** be buried to the same depth as the building ground ring, wherever practical. See ANSI T1.313-2003, figure 3(a).
- The fence fabric near each corner bonding point **shall** also be bonded to the building ground ring. This bond may be made using the same grounding conductor used for the corner fence post, or by bonding directly to the fence post using approved methods described within this chapter. The fence fabric bond should be made in at least three points down the fence fabric as shown in Figure 4-49 (MIL-HDBK-419A Volume II, section 1.12).

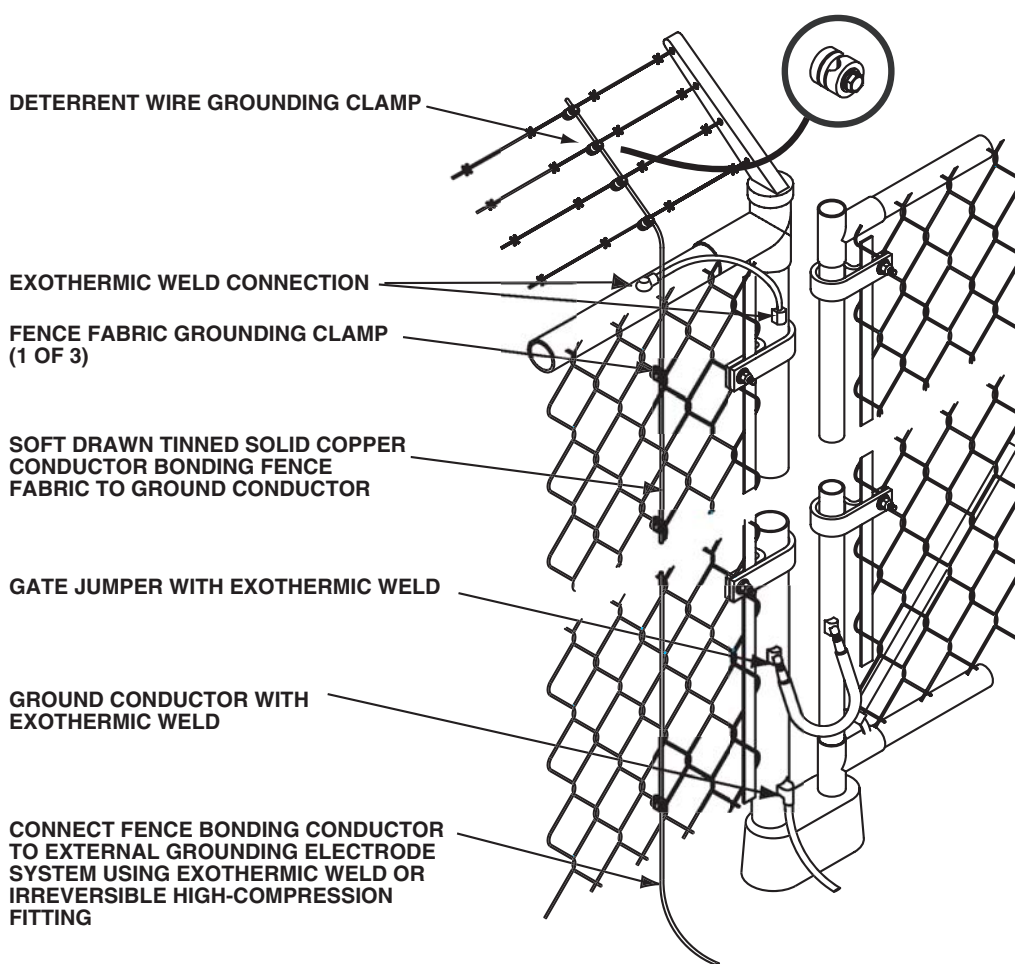

FIGURE 4-49 FENCE FABRIC AND DETERRENT WIRING BONDING EXAMPLE

- All gate posts (on both sides of the gate) **shall** be bonded to the nearest location of the building ground ring using 35 mm² csa (#2 AWG) or coarser, bare, solid or stranded, tinned, copper conductors. The grounding conductors **shall** be buried to the same depth as the building ground ring, whenever practical. (ANSI T1.313-2003, figure 3(a)).
- All gates **shall** be bonded to the gate supporting fence post with 16 mm² csa (#6 AWG) or coarser, stranded, copper conductors. This jumper wire should be constructed with a highly flexible conductor (ANSI T1.313-2003, figure 3(a)). See Figure 4-50 for an example.

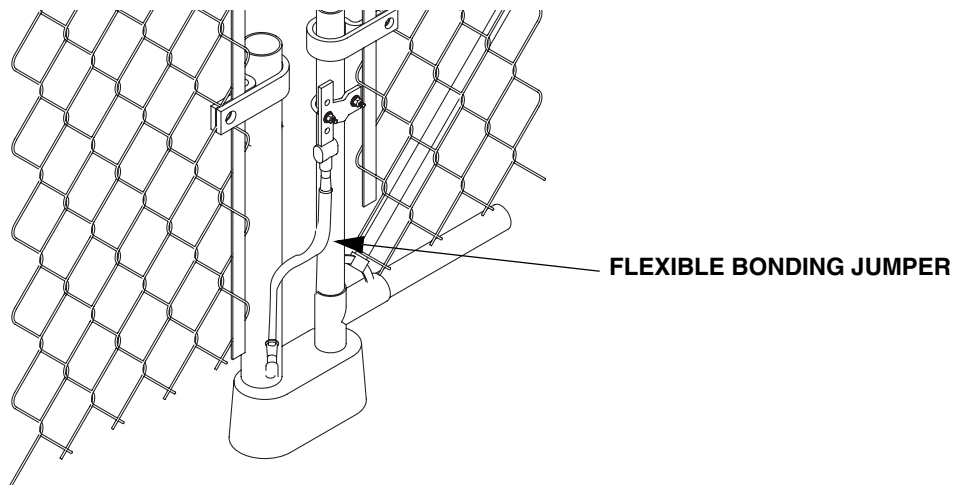

FIGURE 4-50 GATE BONDING EXAMPLE

If the site has non-electrified entry deterrent fence headers of barbed wire, razor wire, or other metallic wiring, the headers **shall** be grounded/bonded as follows:

- The deterrent wiring, near each corner fence post, **shall** be bonded to the nearest location of the building ground ring using 35mm² csa (#2 AWG) or coarser, bare, solid or stranded, tinned, copper conductor. This bond may be made using the same grounding conductor used for bonding the fence fabric. See Figure 4-49 for an example.
- Each individual run of the deterrent wiring **shall** be bonded using a listed bimetallic transition connector. Each connection **shall** be liberally coated with a listed conductive antioxidant compound at the point of insertion into the connector.
- The grounding conductor **shall** be routed so as not come into incidental contact with the deterrent wiring, fence post, fence fabric or support apparatus for the wire. Incidental contact can create an RF interference point.
- The grounding conductor **shall** follow the proper routing methods described in “Bending And Routing Grounding (Earthing) Conductors” on page 4-29.

NOTE: Consult with Motorola Engineering or other engineering firm for the grounding requirements/recommendations of fence systems that extend well beyond the communications building and tower.

Grounding electrode system connections to commercial-grade fencing and gates **shall** be made using the exothermic welding process where possible. Coat all welded connections with zinc-enriched paint to prevent rusting. If exothermic welding is not possible, use the methods described below for residential fencing.

If the site has residential quality fencing and/or preexisting fencing, it **shall** be grounded using heavy duty, tinned pipe clamps designed for fence grounding and stainless steel hardware (or equivalent). Residential-grade and/or preexisting fencing will not typically withstand exothermic welding.

Fences around tower guy anchor points **shall** be bonded to the guy anchor ground rod using 35 mm² csa (#2 AWG) or coarser, bare, solid, tinned, copper conductors and bonded as outlined above. Guy anchor fence gates **shall** be bonded as described above.

**CAUTION**

Braided straps shall not be used because they corrode too quickly and can be a point for RF interference.

4.7.10.2 CABLE BRIDGE/ICE BRIDGE GROUNDING (EARTHING)

Cable bridges and ice bridges are used to protect and support RF transmission lines between the tower structure and the equipment building/shelter. When present, cable bridges and ice bridges **shall** be bonded to the grounding (earthing) electrode system.

Grounding of **self-supported** cable bridges/ice bridges **shall** be completed as follows (Figure 4-51):

- Each support post **shall** bond to the grounding electrode system using a 35 mm² csa (#2 AWG) or coarser, bare, tinned, copper conductor.
- Conductor bonding to the grounding electrode system **shall** be made using exothermic welding or listed irreversible high-compression fittings. See “Bonding to the External Grounding (Earthing) Electrode System” on page 4-40
- Conductor bonding to the support posts **shall** be made using exothermic welding. See “Bonding to the External Grounding (Earthing) Electrode System” on page 4-40
- To help insure effective bonding connections, the cable bridge/ice bridge should bond to each support post using a using a 16 mm² csa (#6 AWG) or coarser, jacketed (ANSI T1.334-2002, section 5.1), copper conductor (bonding jumper). Conductor bonding to the support post **shall** be made using exothermic welding. Conductor bonding to the cable bridge/ice bridge **shall** be made using exothermic welding, or listed two-hole lugs and stainless steel hardware.
- If more than one span of cable bridge/ice bridge is used between the tower and building, bonding jumpers should be installed between the sections to help ensure effective bonding. The bonding jumpers **shall** be a 16 mm² csa (#6 AWG) or coarser copper conductor. The bonding jumpers should use listed two-hole lugs and stainless steel hardware.

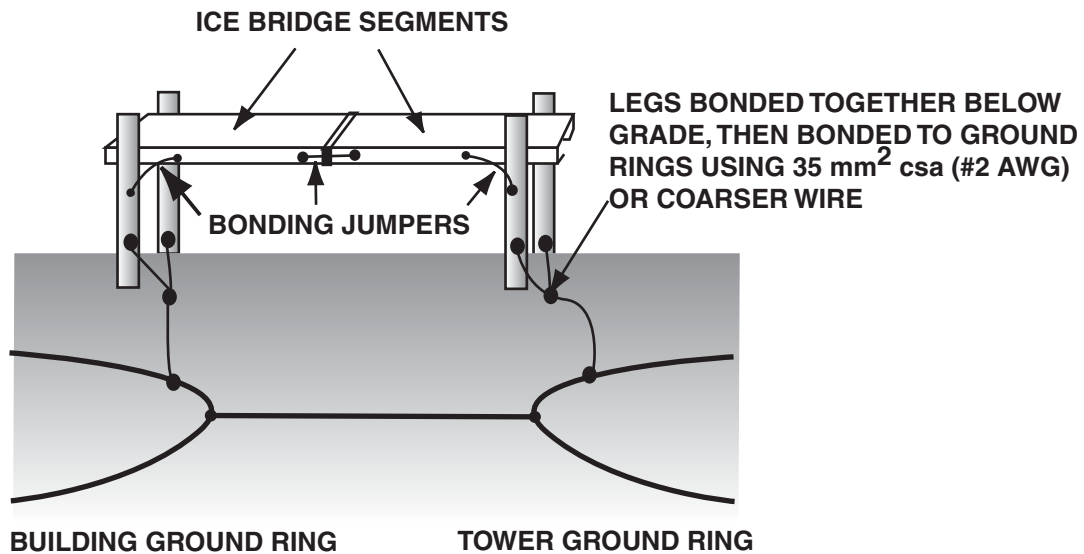

FIGURE 4-51 PROPER GROUNDING OF SELF-SUPPORTING ICE BRIDGE

Grounding of **tower and/or building supported** cable bridges/ice bridges **shall** be completed as follows:

- At the building:** The cable bridge/ice bridge **shall** bond to the grounding electrode system. Bonding to the grounding electrode system may be accomplished using a 16 mm² csa (#6 AWG) or coarser copper conductor bonded to the External Ground Bus bar (EGB). Conductor bonding to the cable bridge/ice bridge and EGB **shall** be made using exothermic welding, or two-hole lugs and stainless steel hardware. See “Bonding to the External Grounding (Earthing) Electrode System” on page 4-40.

Bonding of the cable bridge/ice bridge to the grounding electrode system may also be accomplished using a 35 mm² csa (#2 AWG) or coarser, bare, copper conductor bonded directly to the grounding electrode system. Conductor bonding to the grounding electrode system **shall** be made using exothermic welding or listed irreversible high-compression fittings. Conductor bonding to the cable bridge/ice bridge **shall** be made using exothermic welding, or listed two-hole lugs and stainless steel hardware. See “Bonding to the External Grounding (Earthing) Electrode System” on page 4-40.
- At the tower:** Cable bridges/ice bridges may be sufficiently grounded when an integral part of the tower construction and bonded directly to the tower through multiple metallic mechanical connections. The metallic connections **shall** be of the same metals and **shall** provide direct metal-to-metal contact without any non-conductive coatings, such as paint. When the cable bridge/ice bridge is not effectively bonded to the tower, additional bonding **shall** be required in order to effectively ground the cable bridge/ice bridge.

The additional bonding **shall** be accomplished using one of the following techniques:

- Installing a 16 mm² csa (#6 AWG) or coarser copper conductor (bonding jumper) between the cable bridge/ice bridge and the tower. Conductor bonding to the cable bridge/ice bridge **shall** be made using exothermic welding, or listed two-hole lugs and stainless steel hardware. Conductor bonding to the tower **shall** be made using exothermic welding, or other suitable hardware. See “Bonding to the External Grounding (Earthing) Electrode System” on page 4-40.

- Installing a 16 mm² csa (#6 AWG) or coarser copper conductor (bonding jumper) between the cable bridge/ice bridge and the tower ground bus bar (TGB). Conductor bonding to the cable bridge/ice bridge and TGB **shall** be made using exothermic welding, or listed two-hole lugs and stainless steel hardware. See “Bonding to the External Grounding (Earthing) Electrode System” on page 4-40.
- Installing a 35 mm² csa (#2 AWG) or coarser, bare, copper conductor bonded directly to the grounding electrode system. Conductor bonding to the grounding electrode system **shall** be made using exothermic welding or listed irreversible high-compression fittings. Conductor bonding to the cable bridge/ice bridge **shall** be made using exothermic welding, or listed two-hole lugs and stainless steel hardware. The grounding conductor should be installed in a flexible non-metallic conduit to help prevent incidental contact with other metals, allow for protection of the conductor, and to help support the conductor.

In order to reduce the amount of lightning energy diverted towards the equipment building/shelter, and to provide seismic isolation between the building and tower, it is recommended to secure the cable bridge/ice bridge to the tower through a non-conductive slip-joint type device. When a slip-joint type device is used, grounding of the cable bridge/ice bridge at the building **shall** be completed as described above; grounding at the tower end of the cable bridge/ice bridge **shall** be completed as follows:

- Installing a 35 mm² csa (#2 AWG) or coarser, bare, copper conductor bonded directly to the grounding electrode system. Conductor bonding to the grounding electrode system **shall** be made using exothermic welding or listed irreversible high-compression fittings. Conductor bonding to the cable bridge/ice bridge **shall** be made using exothermic welding, or listed two-hole lugs and stainless steel hardware. The grounding conductor should be installed in a flexible non-metallic conduit to help prevent incidental contact with other metals, allow for protection of the conductor, and to help support the conductor. See Figure 4-52.

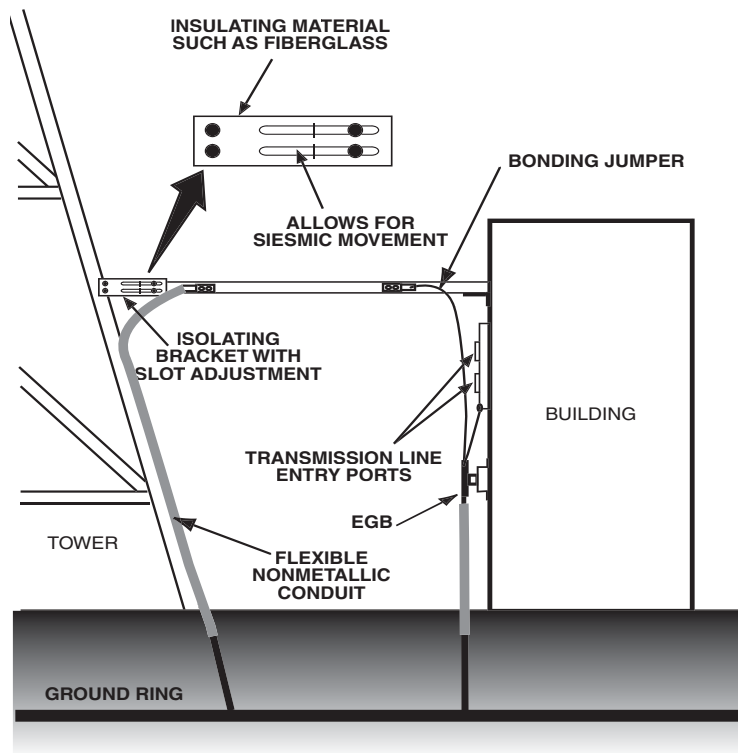

FIGURE 4-52 PROPER GROUNDING OF NON-SELF-SUPPORTING ICE BRIDGE

IMPORTANT: In ice prone areas, if isolating the cable bridge/ice bridge from the tower creates an unprotected area on the RF transmission lines, some type of ice shield **shall** be installed above the isolation point in order to protect the RF transmission lines. The ice shield **shall** be bonded to the tower only.

4.7.11 METALLIC BUILDING SIDING GROUNDING (EARTHING)

Although metallic building siding is not required to be grounded by this standard, grounding the metallic siding can provide additional safety at the site (NFPA 70-2005, Article 250.116-FPN). It is recommended to bond the metallic building siding in at least one location on the building, preferably near the electrical service entrance.

4.8 GROUNDING (EARTHING) ROOF-MOUNTED ANTENNA MASTS AND METAL SUPPORT STRUCTURES

All roof-mounted antenna masts and metal support structures **shall** be grounded (earthed) (NFPA 70-2005, Article 810.15).

NOTE: Rooftop mounted towers are not covered in this section. See “Grounding (Earthing) Rooftop Mounted Tower Structures” on page 4-79 for information about rooftop tower grounding requirements.

In new construction, provisions **shall** be engineered into the building design for effective roof-mounted antenna mast and support structure grounding. Typically this will include a grounding point, or multiple grounding points, with at least two direct connections to the building's grounding electrode system. The direct connection to the building's grounding electrode system may be made using effectively grounded structural building steel (preferred) and/or down-conductors. Other engineered antenna mast and support structure grounding systems may include metallic antenna support structures that are directly and effectively bonded to effectively grounded structural building steel.

When a lightning protection system is installed on the building, roof-mounted antenna masts and support structures **shall** be bonded to the lightning protection system (IEC 61024-1-2 and NFPA 780-2004, section 4.17). The conductor **shall** be of the same size as the Main Roof Perimeter Lightning Protection Ring (FAA STD-019d-2002, section 3.7.9.4). Conductor bonding **shall** be made using exothermic welding, listed irreversible high-compression fittings, or other fittings listed for use in lightning protection systems. See “Bonding to the External Grounding (Earthing) Electrode System” on page 4-40. No additional grounding **shall** be required of roof-mounted antenna masts and support structures when bonded to a lightning protection system.

When a lightning protection system is not available, roof-mounted antenna masts and metal support structure **shall** be grounded by directly bonding to the building's grounding electrode system, or to a supplemental grounding electrode system (FAA STD-019d-2002, section 3.7.9.4). Bonding to the grounding electrode system **shall** use effectively grounded structural building steel when available. When effectively grounded structural building steel is not available, bonding to the grounding electrode system **shall** use at least two down conductors whenever practical (ANSI T1.334-2002, section 8.2). When effectively grounded structural building steel is not available and the use of two down conductors is not practical, the use of a single down conductor should be approved by an engineer. Available water piping systems may also be used as a grounding down-conductor, but should only be used under the advice of an engineer.

Bonding to the structural building steel **shall** be made using exothermic welding, listed irreversible high-compression fittings, or other fittings listed for use in lightning protection systems. See NFPA 780-2004, section 4.16 for additional information regarding the use of structural building steel as a main grounding conductor. Figure 4-53 shows examples of acceptable building steel bonding connections.

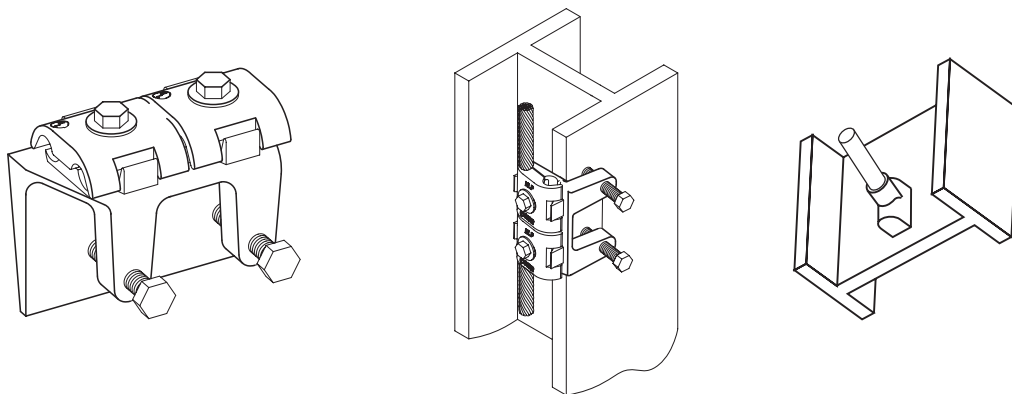

FIGURE 4-53 ACCEPTABLE STRUCTURAL BUILDING STEEL BONDING CONNECTIONS

Down-conductors **shall** be routed to the grounding electrode system from opposite sides of the roof whenever practical (ANSI T1.334-2002, section 8.2). Down-conductors **shall** be physically separated from one another as much as practical (ANSI T1.334-2002, section 8.2). Additional requirements for down-conductors are as follows:

- Grounding down-conductors **shall** be sized as follows:
 - The conductor **shall** be a 35 mm² csa (#2 AWG) or coarser, bare, copper or equivalent, for buildings not exceeding 22.9 m (75 ft.) in height (NFPA 780-2004, Table 4.1.1.1(A)).
 - The conductor **shall** be a 70 mm² csa (#2/0 AWG) or coarser, bare, copper or equivalent, for buildings equal to or exceeding 22.9 m (75 ft.) in height (NFPA 780-2004, Table 4.1.1.1(B)).
- Grounding down-conductors **shall** be protected from physical damage (NFPA 70-2005, Article 810.21(d) and NFPA 780-2004, section 4.9.11). See “Protecting and Securing Grounding (Earthing) Conductors” on page 4-30.
- Grounding down-conductors **shall** be permitted to be run either outside or inside the building or structure (NFPA 70-2005, Article 810.21(g)).

- Grounding down-conductors **shall not** be required to be insulated (NFPA 70-2005, Article 810.21(b)). Insulated conductors are recommended when the grounding conductor may come into incidental contact with other metallic objects. Incidental contact with other metallic object may be a point for RF interference. See Chapter 8, “Minimizing Site Interference.”
- Grounding down-conductor **shall** be run in as straight a line as is practical (NFPA 70-2005, Article 810.21(e)). See “Bending And Routing Grounding (Earthing) Conductors” on page 4-29.
- Grounding down-conductors **shall** have a minimum bend radius of 203 mm (8 in.), and the included angle **shall not** exceed 90 degrees as shown in Figure 4-22 on page 4-29 (ANSI T1.313-2003, section 11.3; MIL-STD-188-124B; and NFPA 780-2004, section 4.9.5). See “Bending And Routing Grounding (Earthing) Conductors” on page 4-29.
- Grounding down-conductors **shall** be securely fastened at intervals not exceeding 914 mm (3 ft.). (See NFPA 70-2005, Article 250.64(b), 810.21(c) and NFPA 780-2004, section 4.10 for additional information.) See “Protecting and Securing Grounding (Earthing) Conductors” on page 4-30.
- Grounding down-conductors run outside from the roof top to ground **shall** be protected for a minimum distance of 1.8 m (6 ft.) above grade level when located in areas susceptible to damage; such areas may include, but are not limited to, runways, driveways, school playgrounds, cattle yards, public walks (NFPA 780-2004, section 4.9.11 and section 4.9.11.2). See “Protecting and Securing Grounding (Earthing) Conductors” on page 4-30.

If the building grounding electrode system resistance cannot be verified or cannot provide a low-resistance to earth (see “Grounding (Earthing) Electrode System Testing/Verification” on page D-1), a supplemental grounding electrode system should be installed to ensure the resistance requirement of the site is met. The supplemental grounding electrode system **shall** be bonded to the existing grounding electrode system (NFPA 70-2005). See “Common Grounding (Earthing)” on page 4-5. See Figure 4-54 for an example of a supplemental grounding electrode system.

NOTE: Consult the building engineer or manager to determine information about any existing building grounding electrode systems. The building engineer should also be informed before attempting to weld or drill on the building rooftop.

NOTE: Depending on the available locations for grounding down-conductors and the entry point of the RF transmission lines into the building, it may be necessary to install a supplemental grounding electrode system.

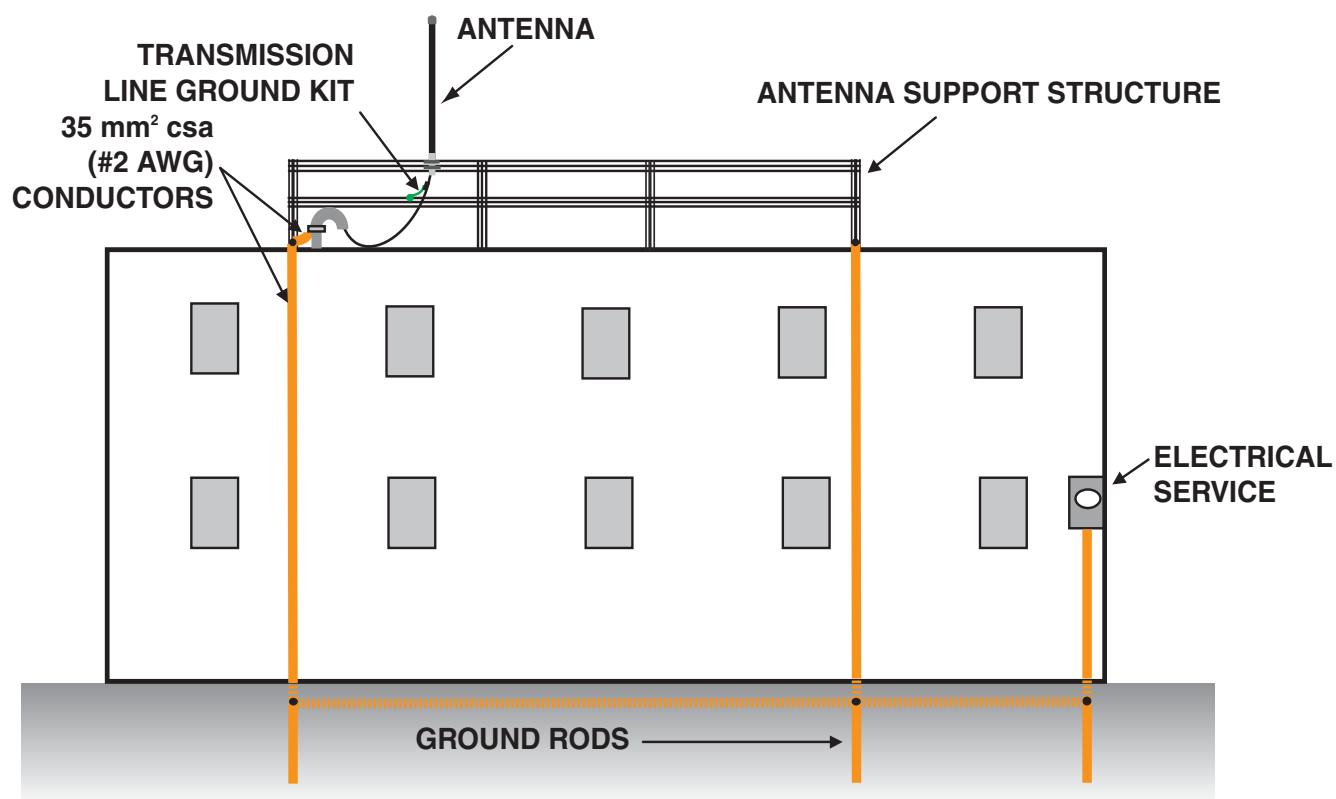

FIGURE 4-54 ROOF MOUNTED ANTENNA MAST GROUNDING WITH SUPPLEMENTAL GROUNDING ELECTRODE SYSTEM

IMPORTANT: When installed, supplemental grounding electrode systems **shall** be effectively bonded to the building grounding electrode system. See “Common Grounding (Earthing)” on page 4-5.

4.8.1 SIDE MOUNTED ANTENNA GROUNDING (EARTHING)

Typically, a side mounted antenna may be grounded (earthed) with a single grounding conductor. The use of two grounding down-conductors may not always be practical. However, two down-conductors should be used whenever practical; this is especially important at buildings that are normally occupied, such as dispatch centers. When two grounding down-conductors are not installed, it is recommended to either use a copper strap or a larger sized grounding down-conductor.

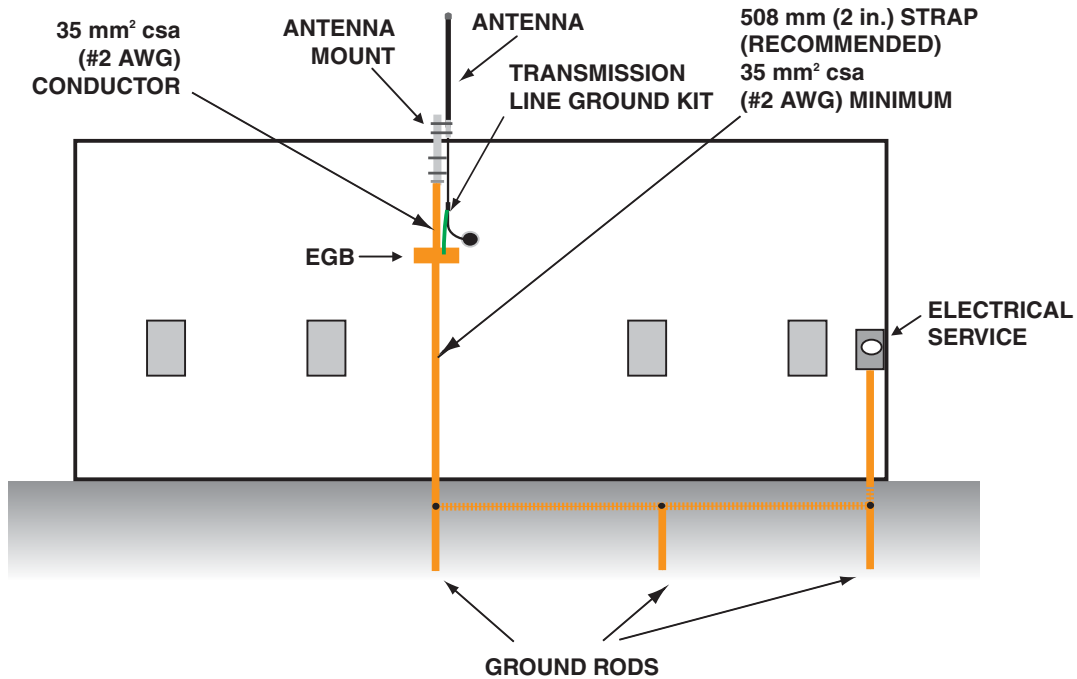

FIGURE 4-55 SIDE-MOUNTED ANTENNA GROUNDING USING COPPER STRAP DOWN CONDUCTOR

When multiple side mounted antennas are installed together, a single horizontal grounding conductor should bond all antenna masts together. The horizontal grounding conductor should bond to the grounding electrode system from each side of the side mounted antennas with a grounding down-conductor. When several antennas are installed together, therefore, creating a long horizontal grounding conductor, it is recommended to install intermediate grounding down-conductors every 6.1 m (20 ft.).

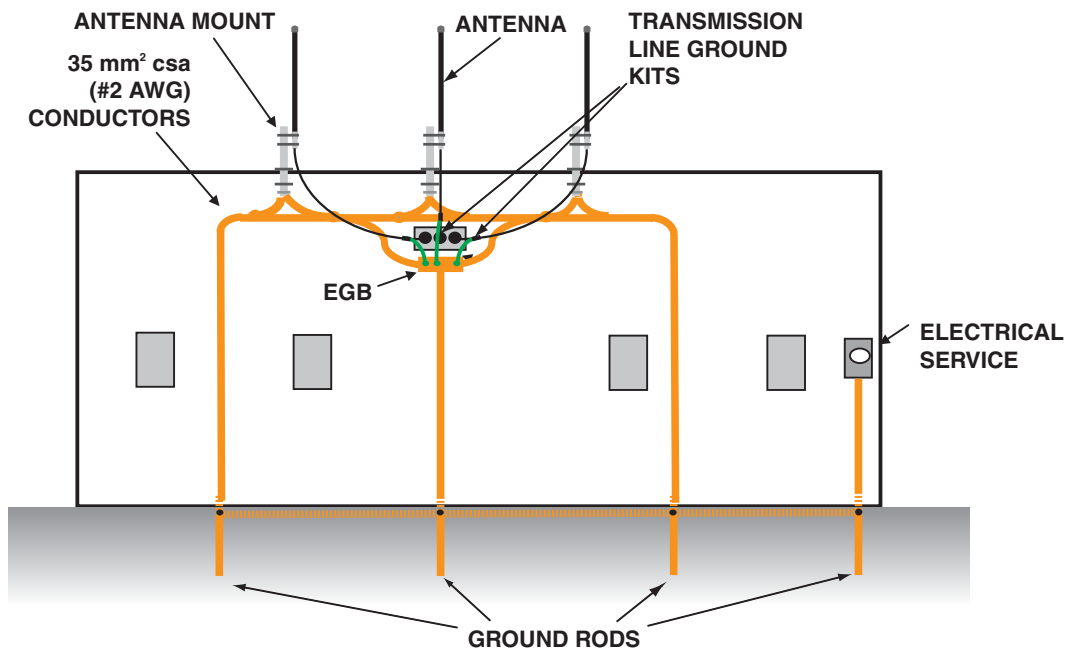

FIGURE 4-56 GROUNDING OF MULTIPLE SIDE-MOUNTED ANTENNAS

4.9 GROUNDING (EARTHING) ROOFTOP MOUNTED TOWER STRUCTURES

Rooftop mounted towers may increase the lightning risk index for the buildings they are installed upon. Due to their increased height and lightning risk probability, all exposed buildings with rooftop towers **shall** be equipped with a lightning protection system, as outlined in NFPA 780-2004 (ANSI T1.313-2003, section 10.3.3). See “Lightning Activity and Exposure” on page 4-3 for information regarding lightning exposure to buildings and towers.

NOTE: Consult the building engineer or manager to determine information about any existing building grounding (earthing) electrode systems. The building engineer should also be informed before attempting to weld or drill on the building rooftop.

An engineering firm specializing in the design and installation of lightning protection systems should be consulted for proper design and installation of the building lightning protection system. A licensed contractor specializing in the installation of lightning protection systems should be used. The lightning protection system **shall** be constructed of only listed components. The lightning protection system **shall** meet the requirements of BS 6651:1999, IEC 61024-1-2, NFPA 780-2004, or other standard in effect and recognized by the local authority having jurisdiction. As a minimum the lightning protection system **shall** contain the following:

- The lightning protection system **shall** contain a grounding conductor installed around the roof perimeter to form the main roof perimeter lightning protection ring. The main roof perimeter lightning protection ring **shall** be sized as follows:
 - The conductor **shall** be a 35 mm² csa (#2 AWG) or coarser, bare, copper or equivalent, for buildings not exceeding 22.9 m (75 ft.) in height (NFPA 780-2004, Table 4.1.1.1(A)).
 - The conductor **shall** be a 70 mm² csa (#2/0 AWG) or coarser, bare, copper or equivalent, for buildings equal to or exceeding 22.9 m (75 ft.) in height (NFPA 780-2004, Table 4.1.1.1(B)).
- Strike termination devices, also known as air terminals, are typically installed along the length of the main roof perimeter lightning protection ring, typically every 6.1 m (20 ft.) or as otherwise required by the standard in effect and recognized by the local authority having jurisdiction.
- The main roof perimeter lightning protection ring **shall** contain at least two down conductors connected to the grounding electrode system. The down conductors **shall** be physically separated from one another as much as practical. The down conductors **shall** be sized as follows:
 - The conductor **shall** be a 35 mm² csa (#2 AWG) or coarser, bare, copper or equivalent, for buildings not exceeding 22.9 m (75 ft.) in height (NFPA 780-2004, Table 4.1.1.1(A)).
 - The conductor **shall** be a 70 mm² csa (#2/0 AWG) or coarser, bare, copper or equivalent, for buildings equal to or exceeding 22.9 m (75 ft.) in height (NFPA 780-2004, Table 4.1.1.1(B)).

NOTE: Available effectively grounded structural building steel can typically be used as a grounding down-conductor. The conductor used to bond the main roof perimeter lightning protection ring to the structural building steel **shall** be sized as required in this section for down-conductors. See Figure 4-53 on page 4-75 for an example of acceptable structural building steel bonding connections.

- Structures exceeding 76 m (250 ft.) in perimeter **shall** have a down conductor for every 30.5 m (100 ft) of perimeter or fraction thereof (NFPA 780-2004, section 4.9.10.1).

- Other metallic objects on the roof **shall** be bonded to the roof perimeter lightning protection system ring as required by BS 6651:1999, IEC 61024-1-2, NFPA 780-2004, or other standard in effect and recognized by the local authority having jurisdiction.
- All grounding electrodes at the building **shall** be bonded together to form a single grounding electrode system. See “Common Grounding (Earthing)” on page 4-5.

The rooftop mounted tower **shall** be effectively grounded by bonding to the lightning protection system. The rooftop mounted tower **shall** bond to the lightning protection system as follows:

- The rooftop mounted tower support legs **shall** be interconnected with a conductor to form a roof tower ground ring. A guyed tower base plate can be used in place of the roof tower ground ring. The conductor **shall** be of the same size as the main roof perimeter lightning protection ring.
- The roof tower ground ring **shall** be exothermically bonded to the tower unless specifically directed otherwise by the tower manufacturer.
- The rooftop mounted tower ground ring or guyed tower base plate **shall** bond to the main roof perimeter lightning protection ring with a minimum of two opposing conductors at or within 610 mm (24 in.) of a grounding down conductor, or other main grounding conductor as defined by NFPA 780-2004, such as effectively grounded structural building steel. The conductor **shall** be of the same size and type as the main roof perimeter lightning protection ring.
 - The conductors **shall** meet the installation requirements of “Grounding (Earthing) Conductors” on page 4-28.
 - Conductor bonding **shall** be made using exothermic welding, listed irreversible high-compression fittings, or other fittings listed for use in lightning protection systems. See “Bonding to the External Grounding (Earthing) Electrode System” on page 4-40.
- All tower guy/anchors that are attached directly to the building **shall** be bonded to the main roof perimeter lightning protection ring (ANSI T1.313-2003, section 10.3.3.).
 - The conductors **shall** meet the installation requirements of “Grounding (Earthing) Conductors” on page 4-28.
 - Conductor bonding **shall** be made using exothermic welding, listed irreversible high-compression fittings, or other fittings listed for use in lightning protection systems. See “Bonding to the External Grounding (Earthing) Electrode System” on page 4-40.

See Figure 4-57 for an example of a typical rooftop tower grounding system.

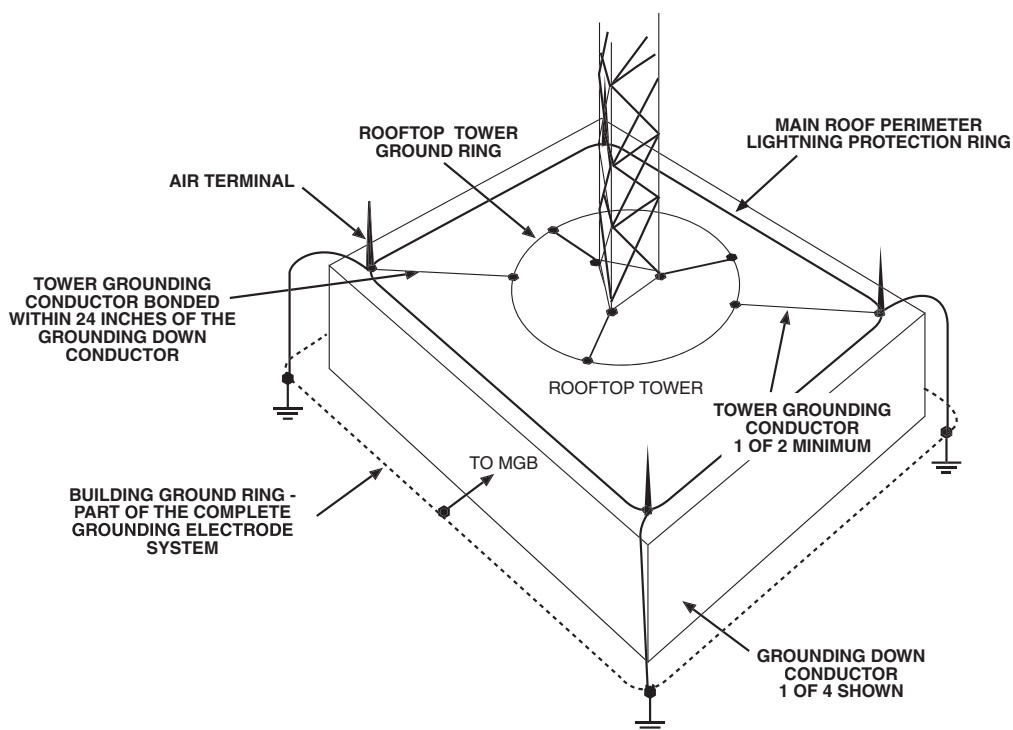

FIGURE 4-57 TYPICAL ROOFTOP TOWER GROUNDING RING

4.10 SPECIAL GROUNDING (EARTHING) APPLICATIONS

Some communications site locations and/or applications require special consideration for effective grounding (earthing). The following sections describe the grounding techniques for some common communications applications. Consultation with Motorola Engineering or other engineering firm may be required in some situations.

4.10.1 EXTERNAL GROUNDING (EARTHING) FOR DISPATCH CENTERS CO-LOCATED WITH COMMUNICATIONS TOWERS

Dispatch centers co-located with communications towers require special protection considerations due to the critical nature of their operation and due to the inherent risk to personnel from lightning. For optimum protection of a dispatch center, the following **shall** be considered:

- Site design recommendations given in “Design Considerations to Help Reduce Effects of Lightning” on page 2-19.
- Internal grounding and bonding as defined in “Grounding (Earthing) for Dispatch Centers and Network Operator Positions” on page 5-62.
- Transient voltage surge suppression (TVSS) As defined in “Surge Protection Considerations for Dispatch Centers and Operator Positions” on page 7-43.

- Electrostatic discharge (ESD) precautions as defined in “Protecting Against Electrostatic Discharge in Equipment Rooms and Dispatch Centers” on page C-1.
- External grounding (earthing) as follows:
 - Grounding electrode system resistance design goal of 5 ohms or less. See “Type “B” Site - Standard Duty” on page 4-45.
 - Installation of all minimum required grounding electrode system components as described in “External Building and Tower Ground Ring” on page 4-22.
 - Bonding of all metallic objects as described in “Metallic Objects Requiring Bonding” on page 4-67.
 - Installation of radial grounding conductors as described in “Radial (Counterpoise) Grounding Conductors” on page 4-24. Radial grounding conductors should be installed regardless if the grounding electrode system resistance is 5 ohms or less without the radial grounding conductors. A minimum of five radial grounding conductors should be installed.

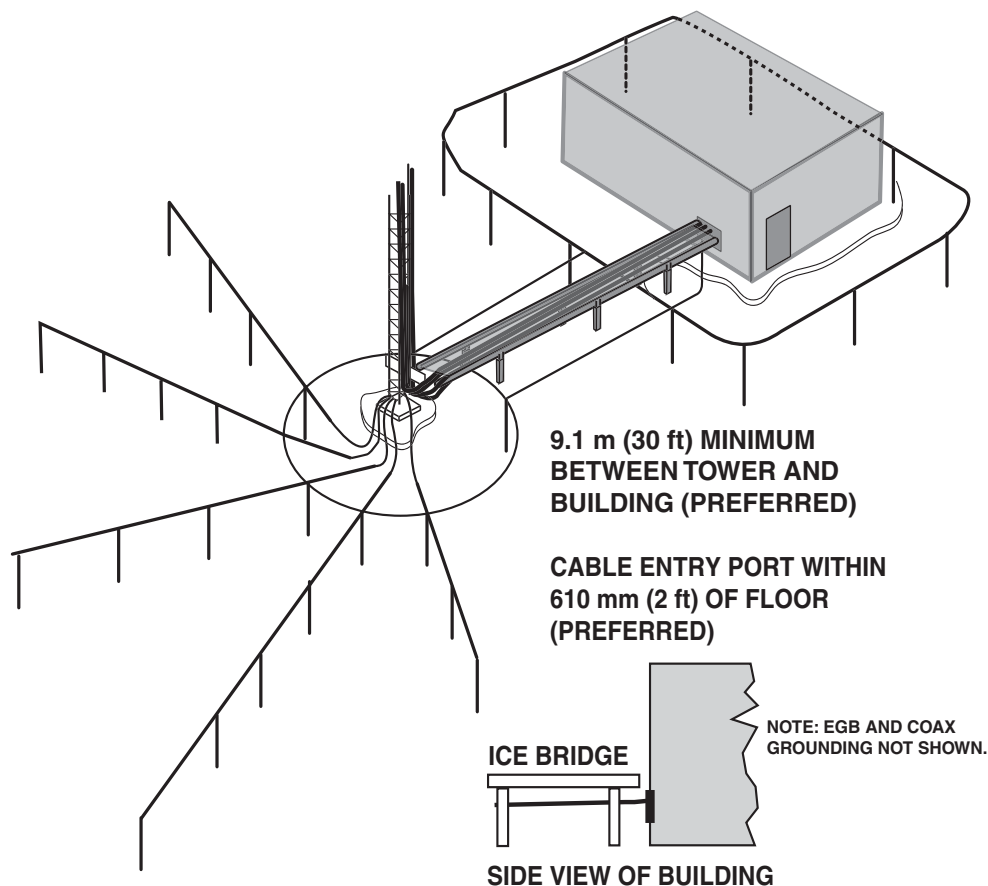

FIGURE 4-58 GROUNDING ELECTRODE SYSTEM FOR DISPATCH CENTER CO-LOCATED WITH A TOWER

4.10.2 TWO OR MORE ELECTRICALLY INTERCONNECTED SEPARATE BUILDINGS LOCATED IN THE SAME GENERAL AREA

When two or more structures or facilities are located in the same general area (less than 61 m (200 ft.) apart) and are electrically interconnected with the continuous metallic shield of signal, control, RF, or monitor circuits, it is recommended to either provide a common grounding (earthing) electrode subsystem, or interconnect the separate grounding electrode systems with two buried grounding conductors. When installed, the grounding conductors **shall** be 50 mm² csa (#1/0 AWG) or coarser, bare, copper. The buried grounding conductors **shall** be installed in separate trenches and buried to a minimum depth of 457 mm (18 in.) below grade. Access to the grounding conductor bonding points should include ground test wells. See Figure 4-59, “Ground Test Wells” on page 4-27, and MIL-HDBK-419A Volume II, section 1.2.3 for additional information.

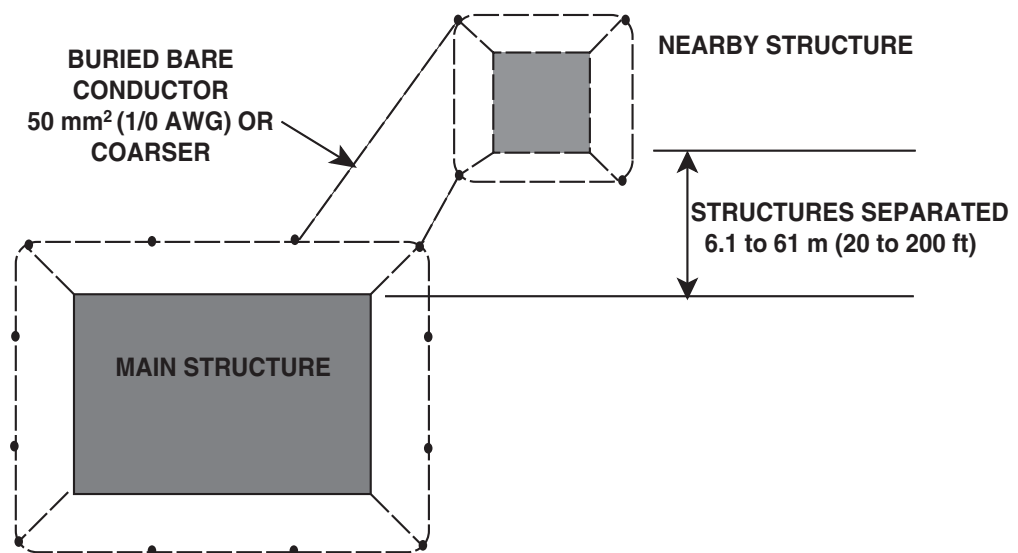

FIGURE 4-59 TWO ELECTRICALLY INTERCONNECTED BUILDINGS LOCATED IN THE SAME AREA

Structures or facilities having no interconnection cables and/or separated by a distance greater than 61 m (200 ft.) generally do not require their grounding electrode systems to be interconnected (MIL-HDBK-419A Volume II, section 1.2.3). Buildings sharing a common tower require bonding of their respective ground rings to the common tower ground ring.

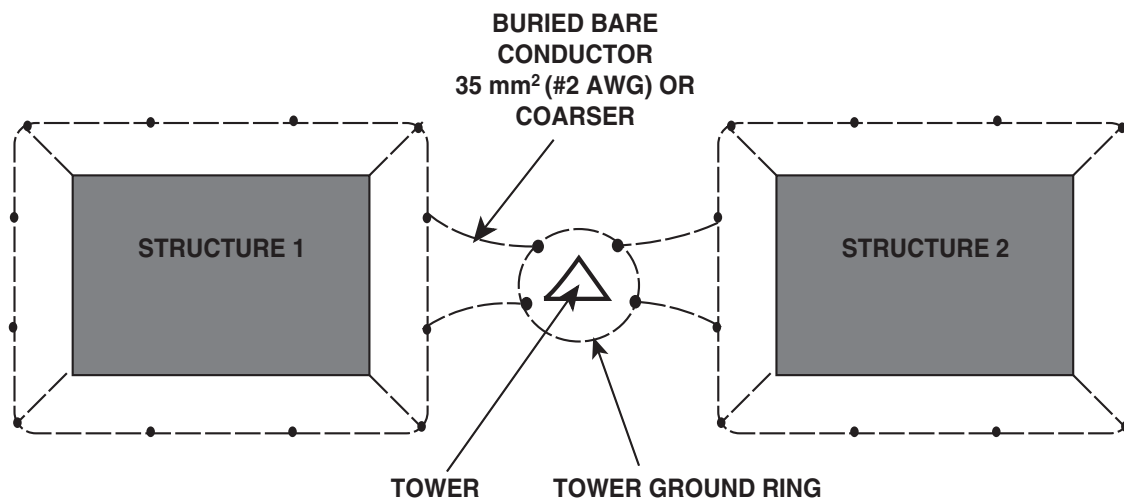

FIGURE 4-60 BONDING TWO STRUCTURES ADJACENT TO THE TOWER

4.10.3 ACCESS POINT AND WIRELESS ROUTER GROUNDING (EARTHING)

Access points, wireless routers, and similar equipment are typically installed in a variety of different locations. Such locations may be on communications towers, building rooftops, or utility light poles. These typical locations are addressed in this section.

4.10.3.1 TOWER MOUNTED

Tower mounted access points and wireless routers **shall** be bonded to the tower using a 16 mm² csa (#6 AWG) or coarser, solid or stranded, tinned and/or jacketed, copper conductor. Connection to access points and wireless routers **shall** be made to an adequately-sized dedicated grounding (earthing) point in accordance with the device manufacturer requirements. Connection to the tower **shall** be made using tower manufacturer-approved methods (typically a type of mechanical clamp). The grounding conductor **shall** meet the specifications and installation requirements of “Grounding (Earthing) Conductors” on page 4-28. The tower **shall** be grounded as described in “Tower Grounding (Earthing)” on page 4-50.

4.10.3.2 BUILDING MOUNTED

Building mounted access points and wireless routers are typically mounted on the side of the building or on the roof of the building. Access points and wireless routers installed inside the building **shall** be grounded (earthed) as required for electronic equipment in Chapter 5, “Internal Grounding (Earthing)”.

4.10.3.2.1 SIDE MOUNTED

Access points and wireless routers mounted to the side of a building **shall** be bonded directly to the building's common grounding (earthing) electrode system using a 16 mm² csa (#6 AWG) or coarser, solid or stranded, copper conductor; grounding conductors installed partially below ground **shall** be 35 mm² csa (#2 AWG) or coarser. Connection to access points and wireless routers **shall** be made to an adequately-sized dedicated grounding point in accordance with the device manufacturer requirements. The grounding conductor **shall** meet the specifications and installation requirements of "Grounding (Earthing) Conductors" on page 4-28.

4.10.3.2.2 ROOF MOUNTED

Access Points and Wireless Routers mounted on the roof of a building **shall** be bonded directly to an available location of the building's common grounding (earthing) electrode system using 16 mm² csa (#6 AWG) or coarser, solid or stranded, copper conductor; grounding conductors installed partially below ground **shall** be 35 mm² csa (#2 AWG) or coarser. Connection to access points and wireless routers **shall** be made to an adequately-sized dedicated grounding point in accordance with the device manufacturer requirements. The grounding conductor **shall** meet the specifications and installation requirements of "Grounding (Earthing) Conductors" on page 4-28.

An available location to the building's common grounding electrode system may include the following:

- Effectively grounded structural building steel.
- An existing communications grounding system.
- An existing lightning protection system down-conductor.
- A grounding down-conductor.
- The device's AC power receptacle conduit when no other ground source is available or practical. When the AC power receptacle conduit is used, the effectiveness of its grounding/bonding connection **shall** be verified.

4.10.3.3 UTILITY POLE MOUNTED

4.10.3.3.1 METALLIC POLE MOUNTED

Access points and wireless routers mounted to metallic utility poles are grounded (earthed) in the same manner as described above for tower-mounted units. Metallic utility pole-mounted access points and wireless routers **shall** be bonded to the metallic utility pole using a 16 mm² csa (#6 AWG) or coarser, solid or stranded, tinned and/or jacketed, copper conductor as shown in Figure 4-61. Connection to access points and wireless routers **shall** be made to an adequately-sized dedicated grounding point in accordance with the device manufacturer requirements. The grounding conductor **shall** meet the specifications and installation requirements of "Grounding (Earthing) Conductors" on page 4-28. Connection to the metallic utility pole **shall** be made using appropriate listed grounding hardware (typically a type of mechanical clamp).

The metallic utility pole **shall** be effectively grounded or made to be effectively grounded. If the utility pole must be made effectively grounded, it **shall** minimally be grounded as described for a Type-A site in "Type "A" Site Grounding (Earthing)" on page 4-48.

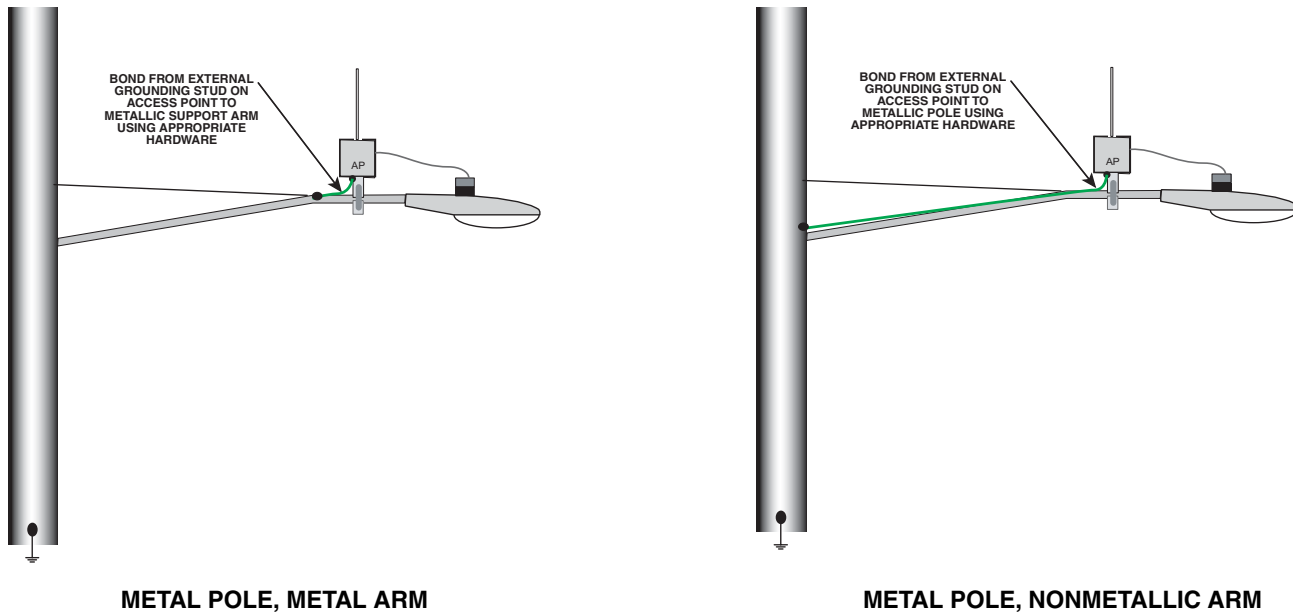

FIGURE 4-61 GROUNDING ACCESS POINT MOUNTED ON METAL POLE

NOTE: If the access point or wireless router is mounted to a non-metallic arm on the metallic utility pole, the access point or wireless router **shall** be grounded as described above by bonding to the metallic portion of the pole as shown in Figure 4-61.

4.10.3.3.2 NON-METALLIC POLE MOUNTED

Non-metallic utility poles used for supporting access points and wireless routers **shall** be grounded (earthed) in the same manner as described in “Wooden Structures (Poles)” on page 4-58. The access points and wireless routers **shall** be bonded to the pole's vertical grounding conductor using a 16 mm² csa (#6 AWG) or coarser, solid or stranded, copper conductor as shown in Figure 4-62. Connection to access points and wireless routers **shall** be made to an adequately-sized dedicated grounding point in accordance with the device manufacturer requirements. Grounding conductors **shall** meet the specifications and installation requirements of “Grounding (Earthing) Conductors” on page 4-28. Bonding to the vertical grounding conductor **shall** be made using listed irreversible compression fittings or exothermic welding as described in “Bonding Methods” on page 4-41.

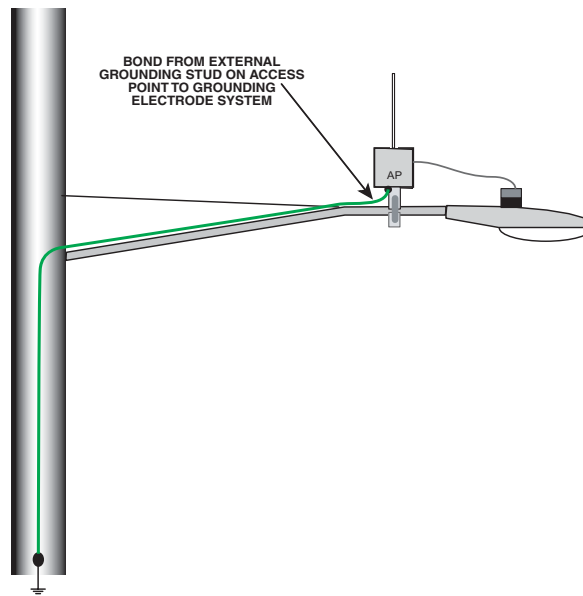

FIGURE 4-62 GROUNDING ACCESS POINT MOUNTED ON NON-METALLIC POLE

4.10.4 METAL SHIPPING CONTAINERS USED AS COMMUNICATIONS BUILDINGS

Grounding (earthing) electrode systems for metal shipping containers used as communications buildings **shall** conform to the requirements specified in this chapter for a dedicated communications building (see “Dedicated Communications Building Grounding (Earthing)” on page 4-59). All equipment inside the shipping container **shall** conform to the grounding requirements of Chapter 5, “Internal Grounding (Earthing).”

In addition to the requirements listed above, the outside of the shipping container **shall** be bonded to the grounding electrode system in at least all four corners using 35 mm^2 csa (#2 AWG) or coarser, bare, solid, copper conductors. Requirements for bonding the metal shipping container to the grounding electrode system are as follows:

- Each corner of the metal container **shall** bond directly to the grounding electrode system.
- Conductors **shall** meet the requirements of “Grounding (Earthing) Conductors” on page 4-28.
- Conductor bonding to the metal shipping container **shall** be exothermically welded whenever practical. See “Exothermic Welding” on page 4-41. When exothermic welding is not practical, other suitable mechanical connections may be used.
- Conductor bonding to the grounding electrode system **shall** be made using exothermic welding or listed irreversible high-compression fittings. See “Bonding to the External Grounding (Earthing) Electrode System” on page 4-40.

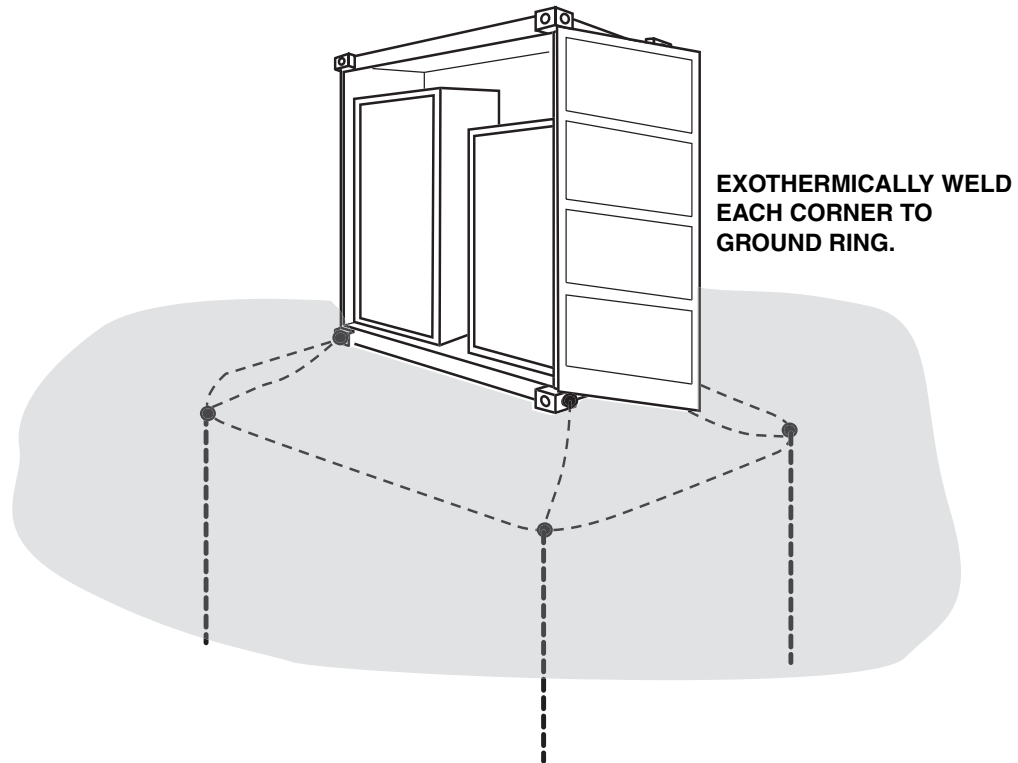

FIGURE 4-63 GROUNDING METAL SHIPPING CONTAINERS

4.10.5 GROUNDING (EARTHING) ELECTRODE SYSTEMS COVERED BY CONCRETE OR ASPHALT

When installing a grounding (earthing) electrode system, every attempt should be made to ensure that the surface area above the grounding electrode system is not covered with concrete or asphalt. Areas covered with concrete or asphalt will dry out over time, therefore increasing the resistance to earth of the grounding electrode system. (See MIL-HDBK-419A for additional information.) Some alternatives to covering the area with concrete and asphalt are listed below:

- Cover the area with gravel.
- Landscape the area.
- Use electrolytic ground rods when the area must be covered with concrete or asphalt.

4.11 SPECIAL GROUNDING (EARTHING) SITUATIONS

Site conditions such as limited area and high (poor) soil resistivity can sometimes require special consideration for effective grounding (earthing). Some methods for achieving an effective grounding electrode system in some common applications are described below in the following sections. Consultation with Motorola Engineering or other engineering firm may be required in some situations.

4.11.1 ROOFTOP AND INTEGRATED COMMUNICATIONS SITES

Rooftop and integrated communications sites (high-rise buildings) may require special techniques for achieving a suitable grounding (earthing) electrode system when effectively grounded structural steel is not available and when encircling the building with a ground ring would not be feasible, such as in a downtown metropolitan location. Some options may be:

- Consult with Motorola Engineering or other engineering firm.
- Installation of a small ground ring in an available location. See Figure 4-64.
- Installation of multiple parallel rods in a straight line. See Figure 4-65.
- Installation of electrolytic ground rod systems.

IMPORTANT: If a supplemental grounding electrode system is installed, it **shall** be bonded to the existing building grounding electrode system. See “Common Grounding (Earthing)” on page 4-5

NOTE: In order to maintain maximum efficiency of parallel ground rods, the ground rods **shall** be separated from one another by twice the length of the individual ground rods.

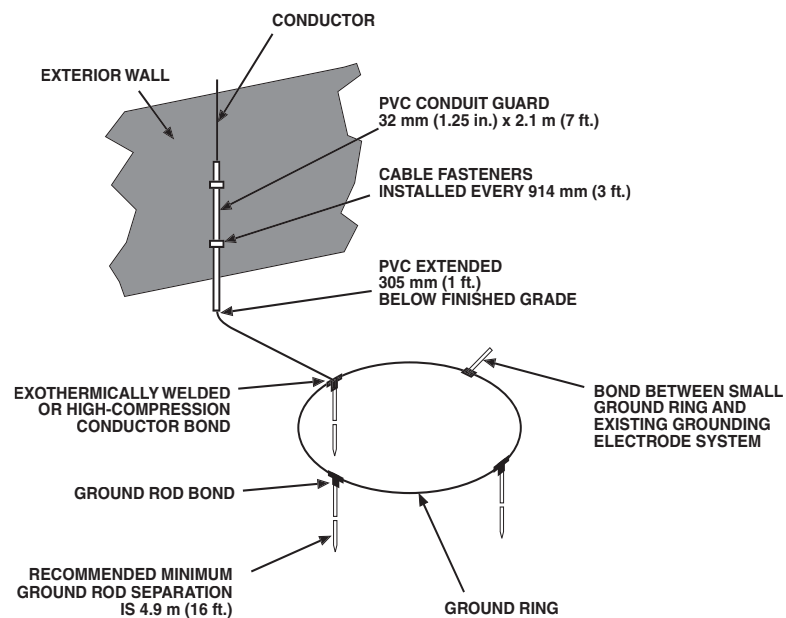

FIGURE 4-64 SMALL GROUND RING INSTALLATION

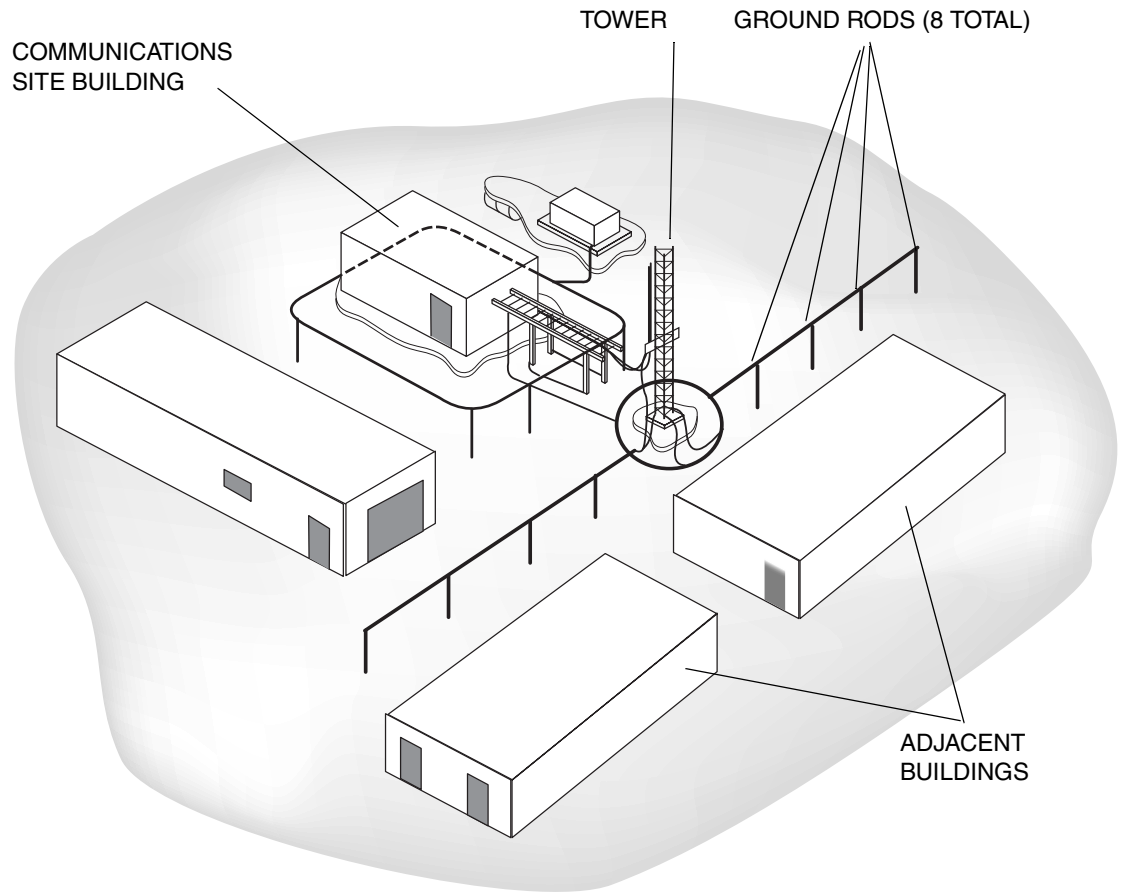

FIGURE 4-65 TYPICAL LINEAR GROUNDING ELECTRODE SYSTEM

4.11.2 SITES WITH LIMITED SPACE FOR THE GROUNDING (EARTHING) ELECTRODE SYSTEM

Some sites, such as locations in metropolitan areas or areas close to adjacent buildings or property lines, have very little space available for installing a grounding (earthing) electrode system. One solution for achieving an acceptable grounding electrode system that meets the resistance requirements defined in this chapter may be to install a grounding electrode grid system using all available space on the property.

A grounding electrode grid system consists of grounding electrodes, typically rods, installed in a grid pattern. The grounding electrodes are all equally spaced and connected together underground with a grounding conductor. See MIL-HDBK-419A for additional information. Requirements for a grounding electrode grid system are as follows:

- The grounding electrodes **shall** meet the specifications and installation requirements of “Grounding (Earthing) Electrodes” on page 4-9.

- Grounding conductors used to connect the grounding electrode **shall** meet the specifications and installation requirements of “Grounding (Earthing) Conductors” on page 4-28. Whenever possible, the grounding conductors **shall** be buried at least 762 mm (30 in.) deep or below the frost line, whichever is deeper.
- Grounding conductors **shall** be bonded together wherever they intersect; this is typically completed at a ground rod or other grounding electrode.
- Bonding of all components **shall** be made using exothermic welding or listed irreversible high-compression fittings. See “Bonding to the External Grounding (Earthing) Electrode System” on page 4-40.

See Figure 4-66 for an example of a grounding electrode grid system for an available area of 9.1 m × 9.1 m (30 ft. × 30 ft.), with all ground rods separated by 3 m (10 ft.).

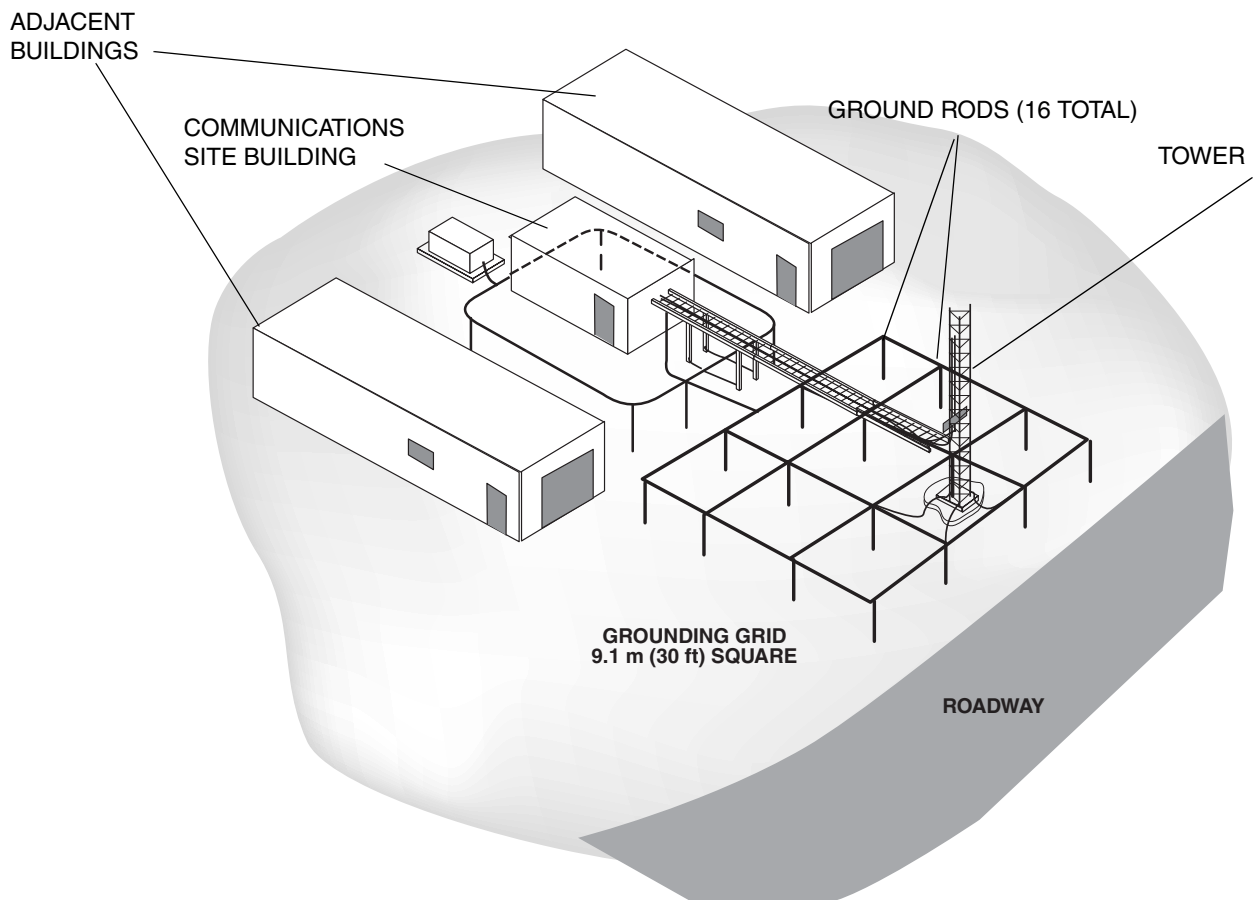

FIGURE 4-66 TYPICAL GROUNDING GRID

See “Interpreting Test Results” on page B-10 to determine if the desired resistance to earth can be achieved using different rod lengths and/or separation. If the resistance to earth cannot be achieved using standard rods, electrolytic rods should be considered. Burying the grounding conductor in at least 152 mm (6 in.) of grounding electrode encasement material should also be considered as a method of improving the resistance to ground. (See “Grounding (Earthing) Electrode Encasement Materials” on page 4-27.)

NOTE: In shallow topsoil conditions, the above grounding electrode grid system can utilize ground plates instead of ground rods.

4.11.3 TOWERS WITH LIMITED SPACE FOR A GROUND RING

Towers installed close to a building may not have adequate space for a complete tower ground ring or for ground rods spaced properly to achieve the resistance requirements of the site. Depending on the available space, the tower can be grounded (earthed) using multiple parallel rods and/or ground radials. (See “Radial (Counterpoise) Grounding Conductors” on page 4-24 and Figure 4-65 on page 4-90.)

See “Interpreting Test Results” on page B-10 to determine the number of rods and rod spacing required to achieve the resistance requirements of the site.

4.11.4 STONE MOUNTAIN TOPS

Some sites are located on mountaintops because of their RF propagation characteristics. In the instances where there is no, or very little, top soil at the site, special designs will be needed. Some options for an effectively grounded (earthed) site are listed below; reasonable attempts should be made to use as many options as possible and as needed to meet the ground resistance requirements of the site:

- Consult with Motorola Engineering or other engineering firm.
- Installation of concrete-encased electrodes as part of new construction. See “Concrete-Encased Electrodes” on page 4-20.
- Installation of radial grounding conductors from the tower and building throughout the property. Install the radial grounding conductors to a depth allowed by the soil, preferably 457 to 762 mm (18 to 30 in.) Encasing the radial grounding conductors in a grounding electrode encasement material can further increase the effectiveness of the grounding electrode system. See “Radial (Counterpoise) Grounding Conductors” on page 4-24.
- Installation of ground rings around the building and tower, with the ground rings buried as deep as the soil will allow. The ground rings should be encased in a grounding electrode encasement material. A conductive concrete may be the best grounding electrode encasement material for use in shallow topsoil environments, since the conductive concrete would not require a covering of topsoil for protection. See “External Building and Tower Ground Ring” on page 4-22 and “Grounding (Earthing) Electrode Encasement Materials” on page 4-27.
- Installation of horizontal ground rods or horizontal electrolytic ground rods along the length of the ground rings instead of vertical ground rods. The ground rods **shall** be installed perpendicular to the building and tower. Encasing the ground rings and horizontal ground rods in a grounding electrode encasement material can further increase the effectiveness of the grounding electrode system.

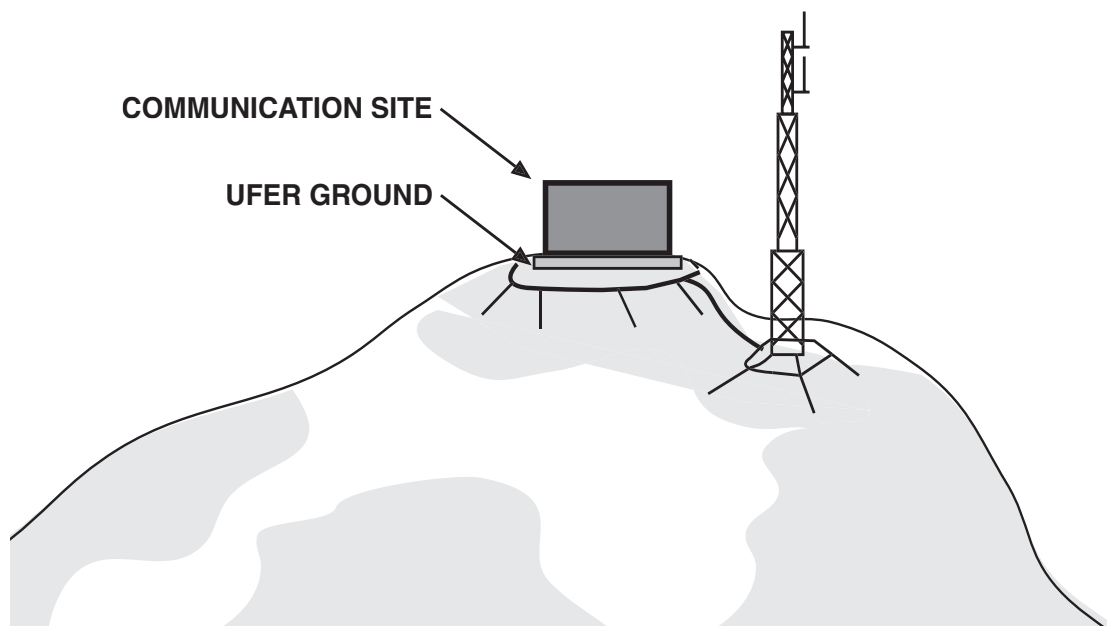

FIGURE 4-67 MOUNTAINTOP SYSTEMS: INSTALLATION OF HORIZONTAL GROUND RODS

- Installation of ground plates along the length of the ground rings instead of vertical ground rods. Encasing the ground rings and ground plates in a grounding electrode encasement material can further increase the effectiveness of the grounding electrode system. See “Ground Plate Electrodes” on page 4-19.

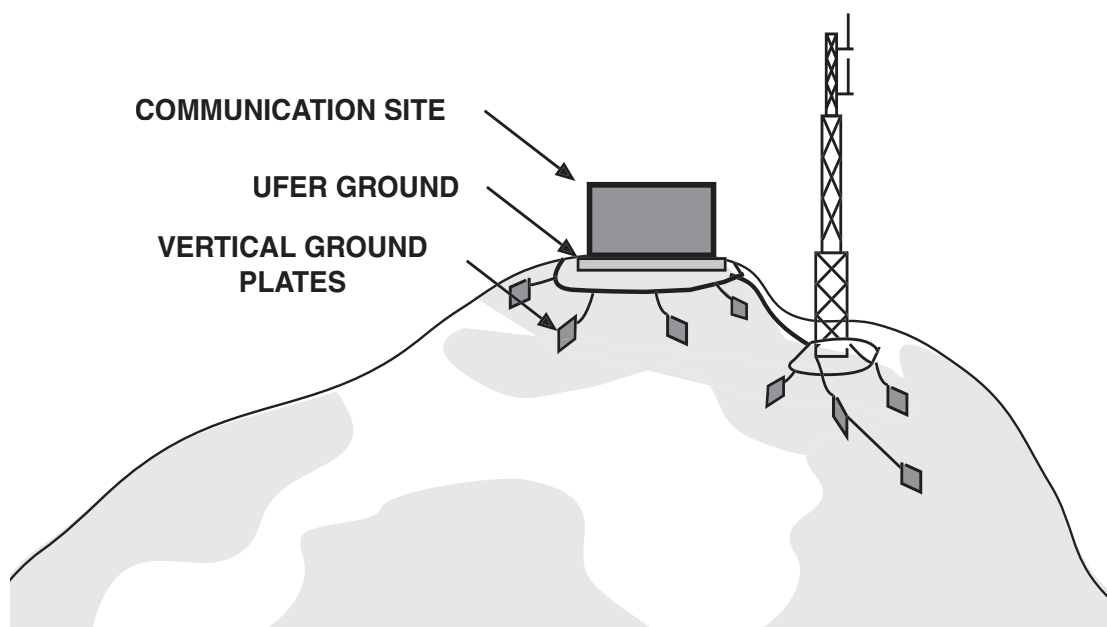

FIGURE 4-68 MOUNTAINTOP SYSTEMS: INSTALLATION OF GROUND PLATES

- Installation of down conductors to a lower area where there is usable soil for the installation of vertical ground rods. The down conductors would be more effective if buried below ground like a radial grounding conductor, wherever possible. The down conductors **shall** be sized according to length as shown below in Table 4-8 (based on MIL-HDBK-419A). See Figure 4-69 on page 4-96.

TABLE 4-8 GROUNDING CONDUCTOR SIZING

Conductor length in linear m (ft)	Conductor size in mm ² csa (AWG / MCM)
Less than 10 (Less than 33)	33.62 (2)
10.36 – 12.5 (34 – 41)	42.4 (1)
12.8 – 16 (42 – 53)	52 (1/0)
16.5 – 20 (54 – 66)	67.4 (2/0)
20.4 – 25.6 (67 – 84)	85 (3/0)
25.9 – 32 (85 – 105)	107 (4/0)
32.3 – 38.1 (106 – 125)	126.70 (250 MCM)
38.4 – 45.7 (126 – 150)	152 (300 MCM)
46 – 53.34 (151 – 175)	177 (350 MCM)
53 – 76.1 (176 – 250)	253.4 (500 MCM)
76.4 – 91.39 (251 – 300)	300 (600 MCM)
Greater than 91.39 (300)	380 (750 MCM)

TABLE 4-9 STANDARD WIRE SIZES AVAILABLE FOR INTERNATIONAL MARKET

Conductor size in mm ² csa	Conductor size in AWG / MCM
6	10
10	8
16	6
25	4
35	2
50	1/0
75	2/0
95	3/0
120	4/0
150	300 MCM
185	350 MCM
240	500 MCM
300	600 MCM
400	800 MCM

NOTE: Down conductors alone should not be relied on for an effective grounding electrode system. Other methods listed in this section, such as building and tower ground rings, should also be used to help achieve an effective grounding electrode system.

- Installation of copper strap radial grounding conductors on the surface of the rocks in all directions from the tower. The copper straps may be covered with top soil and/or ground enhancing material, such as conductive concrete. Each copper strap radial should be a different length to help prevent ringing of the tower during a lightning strike.

IMPORTANT: At sites, such as stone mountain tops, where it is difficult to achieve an effective grounding electrode system, the need for single-point grounding and transient voltage surge suppression (TVSS) on all input/outputs is of paramount importance.

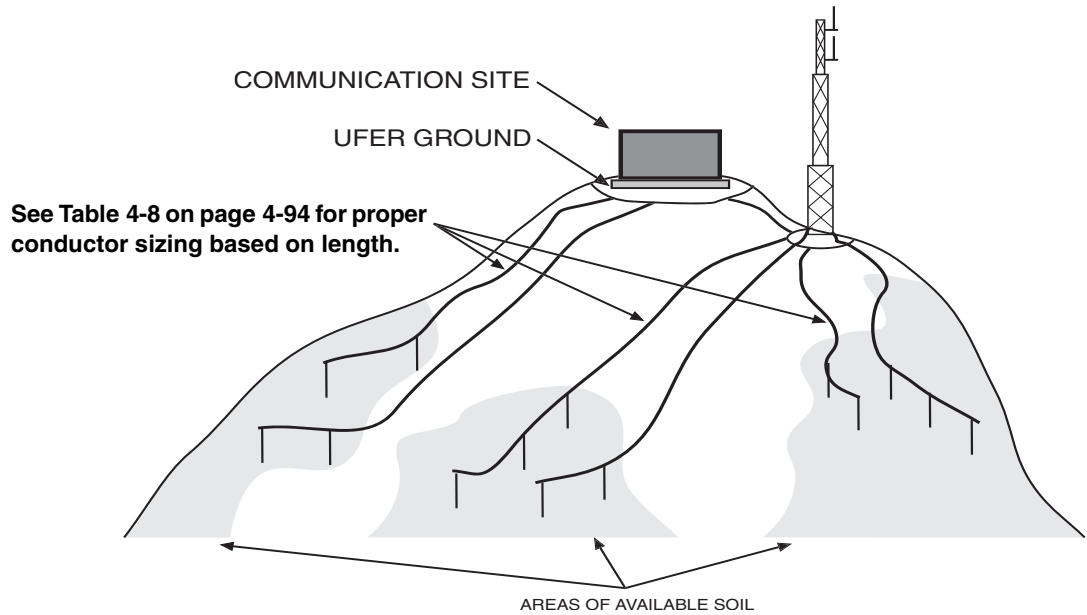

FIGURE 4-69 EXAMPLE OF SOILLESS GROUND SYSTEM

NOTE: The concept of drilling holes in solid rock to insert a ground rod surrounded by a grounding electrode encasement material is generally considered to be ineffective and should not be used without additional grounding electrode system components. Solid rock is no more conductive in a hole than on the surface. Radial grounding conductors encased in a grounding electrode encasement material, such as conductive concrete, would be more effective and more economical.

4.11.5 SAND, CORAL, OR LIMESTONE ENVIRONMENTS

Sites with very high soil resistivity, such as sites with sand, coral and limestone, may require special grounding (earthing) techniques in order to achieve an effectively grounded site. Some options to help achieve an effectively grounded site are as follows:

- Consult with Motorola Engineering or other engineering firm.
- Installation of concrete-encased electrodes as part of new construction. See “Concrete-Encased Electrodes” on page 4-20.
- In addition to the building and tower ground rings, installation of radial grounding conductors with vertical ground rods throughout the available property. Install radial grounding conductors and rods as specified in this chapter. Encasing all components in a grounding electrode encasement material can further increase the effectiveness of the grounding electrode system.
- Installation of electrolytic ground rod systems instead of standard ground rods. See “Electrolytic Ground Rods” on page 4-16.
- In addition to the building and tower ground rings, installation of a grounding electrode grid system throughout the site. See “Sites With Limited Space for the Grounding (Earthing) Electrode System” on page 4-90.

- Using multiple large copper plates (0.88 to 1.8 m² (10 to 20 ft².) buried to an optimal depth of 1.5 m to 2.4 m (5 to 8 ft.). The plates are placed vertically on edge and bonded to the grounding electrode system using exothermically welded 35 mm² csa (#2 AWG) solid copper wire. Placing the plates on vertical edge allows the plates to be buried with a minimum of excavation and may make it possible to obtain more surface area contact with the soil when backfilling. The use of a number of well-placed ground plates in parallel is preferred to placing longer rows of ground plates (IEEE STD 142-1991, section 4.2.4). Encasing the ground plates in a grounding electrode encasement material can further increase the effectiveness of the grounding electrode system.

4.11.6 SHALLOW TOPSOIL ENVIRONMENTS

Some sites are located in areas where bedrock is near the surface or where the top soil is less than 305 mm (1 ft.) deep. These areas require installation of specialized grounding (earthing) electrode systems and may require the support of an engineering firm.

Requirements and recommendations for grounding electrode systems in areas with shallow topsoil are provided below. Reasonable attempts should be made to use as many options as possible and as needed to meet the ground resistance requirements of the site. See NFPA 780-2004, section 4.13.8.1 for additional information.

- Consult with Motorola Engineering or other engineering firm.
- Installation of concrete-encased electrodes as part of new construction. See “Concrete-Encased Electrodes” on page 4-20.
- Installation of ground rings around the building and tower, with the ground rings buried as deep as the soil will allow. The ground rings should be encased in a grounding electrode encasement material. A conductive concrete may be the best grounding electrode encasement material for use in shallow topsoil environments, since the conductive concrete would not require a covering of topsoil for protection. See “External Building and Tower Ground Ring” on page 4-22.
- Installation of ground plates along the length of the ground rings instead of vertical ground rods. The ground plates should be encased in a grounding electrode encasement material. See “Grounding (Earthing) Electrode Encasement Materials” on page 4-27 and “Ground Plate Electrodes” on page 4-19.
- Installation of a grounding electrode grid system, using ground plates instead of vertical ground rods. The grounding conductors and ground plates **shall** be buried as deep as the soil will allow. The grounding conductors should be encased in a grounding electrode encasement material. A conductive concrete may be the best grounding electrode encasement material for use in shallow topsoil environments, since the conductive concrete would not require a covering of topsoil for protection. See “Sites With Limited Space for the Grounding (Earthing) Electrode System” on page 4-90 and Figure 4-66 on page 4-91 for additional information on grounding electrode grid systems.
- Installation of electrolytic ground rod systems. See “Electrolytic Ground Rods” on page 4-16.

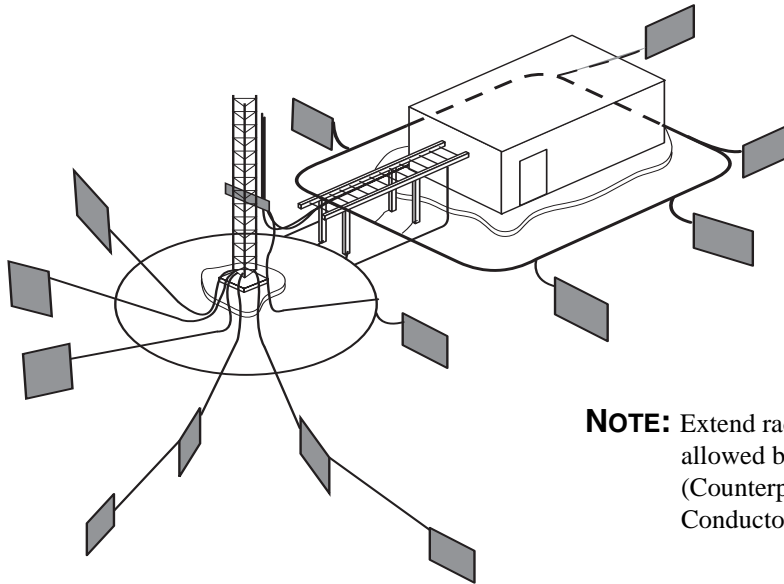

NOTE: Extend radial grounding conductors as allowed by available soil. See “Radial (Counterpoise) Grounding Conductors” on page 4-24.

FIGURE 4-70 GROUNDING ELECTRODE SYSTEM WITH GROUND PLATES

- Installation of building radial grounding conductors in a trench extending away from the building at each corner. The radial grounding conductors **shall** be buried as deep as the soil will allow. The radial grounding conductors **shall** bond to the building ground ring using exothermic welding or listed irreversible high-compression fittings. The radial grounding conductors should be encased in a grounding electrode encasement material. A conductive concrete may be the best grounding electrode encasement material for use in shallow topsoil environments, since the conductive concrete would not require a covering of topsoil for protection. Each radial grounding conductor may have ground plates installed every 1.8 to 4.9 m (6 to 16 ft.) along its length. See Figure 4-71.
- Installation of tower radial grounding conductors in a trench extending away from the tower and building. The radial grounding conductors **shall** be buried as deep as the soil will allow. The radial grounding conductors **shall** bond to the tower ground ring using exothermic welding or listed irreversible high-compression fittings. The radial grounding conductors should be encased in a grounding electrode encasement material. A conductive concrete may be the best grounding electrode encasement material for use in shallow topsoil environments, since the conductive concrete would not require a covering of topsoil for protection. Each radial grounding conductor may have ground plates installed every 1.8 to 4.9 m (6 to 16 ft.) along its length. See Figure 4-71.

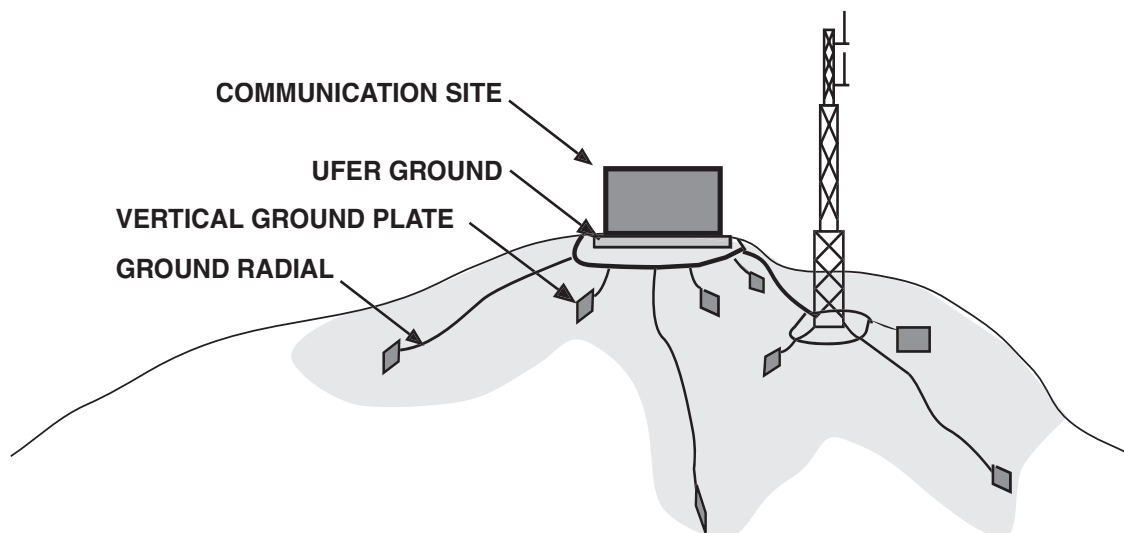

FIGURE 4-71 GROUNDING ELECTRODE SYSTEM WITH GROUND PLATES AND RADIALS

4.11.7 GROUNDING (EARTHING) IN ARCTIC REGIONS

It may be difficult to achieve an effective low resistance grounding (earthing) electrode system at sites located in arctic regions (or similar cold climates). In these cases, consultation with an engineering firm is recommended. The primary issue with achieving an effective grounding electrode system in arctic regions is making good contact with frozen high-resistivity soils. Where frozen high-resistivity soils are encountered, optimum grounding can only be accomplished by special attention to both surface and subsurface terrain. The resistivity of frozen soils can be 10 to 100 times greater than in the unfrozen state; therefore, seasonal changes in temperature and moisture greatly affect the resistance to earth of the grounding electrode system. (See Appendix B for additional information regarding soil resistivity changes as a function of temperature and moisture.) See MIL-HDBK-419-A Volume I, section 2.11.1 for additional information.

Seasonal freezing accounts for an increase in grounding electrode system resistance. If frozen soil has a high resistivity, then providing larger electrodes reduces the resistance to earth. In arctic areas that generally have very shallow surface thaw layers, horizontal rods or conductors may be easier to install than driven rods and provide an equivalent resistance to earth. Whether to install multiple electrodes, or a single deep-driven rod, or horizontal conductors is usually dependent on soil conditions at the site and the economics of installation. See MIL-HDBK-419-A Volume I, section 2.11.1 for additional information.

An option for an effective grounding electrode system may be to install electrolytic ground rods that are encased in a grounding electrode encasement material. See “Electrolytic Ground Rods” on page 4-16 and “Grounding (Earthing) Electrode Encasement Materials” on page 4-27. See MIL-HDBK-419-A Volume I, section 2.11.2 for additional information.

THIS PAGE INTENTIONALLY LEFT BLANK.

INTERNAL GROUNDING (EARTHING)

This chapter provides requirements for grounding (earthing) communications site equipment within a facility. The following topics are included:

- “Common Grounding (Earthing)” on page 5-3
- “Grounding (Earthing) System Components and Installation Requirements” on page 5-4
- “Connection Methods for Internal Grounding (Earthing) System” on page 5-31
- “Bonding Equipment to Internal Grounding (Earthing) System” on page 5-40
- “Grounding (Earthing) for Stand-alone Equipment Shelters” on page 5-54
- “Grounding (Earthing) for Small, Large, and Multi-Story Buildings” on page 5-58
- “Grounding (Earthing) for Dispatch Centers and Network Operator Positions” on page 5-62
- “Grounding (Earthing) for Integrated Communication Sites” on page 5-68

NOTE: Throughout this chapter the terms *grounding* and *earthing* are used synonymously.

5.1 INTRODUCTION

Proper bonding and grounding (earthing) of equipment is essential for personnel safety and system reliability. Because of the increase in circuit density and the advent of lower-voltage integrated circuit devices, communications systems equipment is now more vulnerable than ever to damage resulting from lightning activity and power line anomalies. Inadequate or improper equipment bonding and grounding can permit a difference of ground potential to exist between system components, which may result in injury to personnel, system failure, and equipment damage.

The requirements and guidelines in this chapter are derived from a compilation of local and national codes, widely accepted industry codes and standards, and good engineering practices. Such codes and standards are from, but not limited to, the following standards organizations:

- American National Standards Institute (ANSI)
- Institute of Electrical and Electronics Engineers (IEEE)
- National Fire Protection Association (NFPA)
- Telecommunications Industry Association (TIA)
- Underwriters Laboratories (UL)
- United States Department of Defense (DoD)
- United States Federal Aviation Administration (FAA)
- United States National Weather Service

References to the specific industry codes and standards on which this chapter is based are provided throughout. The requirements and guidelines in this chapter are provided to enhance personnel safety and equipment reliability.

Safety of personnel and protection of sensitive electronics equipment from ground faults, lightning, ground potential rise, electrical surges, and power quality anomalies is of utmost importance at any communications site. Though unexpected electrical events like lightning strikes and power surges cannot be prevented, this chapter provides design and installation information on communications site grounding (earthing) systems that may help minimize damage caused by these events.

**WARNING**

Grounding and bonding alone are not enough to adequately protect a communications site. Transient voltage surge suppression (TVSS) techniques, using appropriate surge protection devices (SPD), shall be incorporated at a communications site in order to provide an adequate level of protection. See Chapter 7 for details and requirements.

**WARNING**

The AC power system ground shall be sized appropriately for the electrical service and shall be approved by the authority having jurisdiction.

An internal grounding system **shall** have low electrical impedance, with conductors large enough to withstand high fault currents. The lower the grounding system impedance, the more effectively the grounding electrode system can dissipate high-energy impulses into the earth.

All site development and equipment installation work **shall** comply with all applicable codes in use by the authority having jurisdiction. Grounding systems **shall** be installed in a neat and workmanlike manner (NFPA 70-2005, Article 110.12 and NFPA 780-2004, section 1.4). Where conflicting, the more stringent standard should be followed. Government and local codes **shall** take precedence over the requirements of this manual.

Unusual site conditions may require additional effort to achieve an effectively bonded and grounded (earthed) site. See Chapter 2, “Site Design and Development”. In these instances, consultation with Motorola Engineering or with an engineering firm specializing in grounding system design is recommended.

Some of the benefits of a properly designed and installed low-impedance grounding system are described below. See ANSI T1.333-2001, section 4; ANSI T1.334-2002, section 5.1; IEEE STD 142-1991, section 1.3; IEEE STD 1100-1999, section 3.3.1; and NFPA 70-2005, Article 250.4 for additional information.

- To help limit potential differences between conductive surfaces caused by electrical disturbances such as electrical power faults, lightning strikes and electrostatic discharges.
- To help provide fault current paths of sufficient current carrying capacity and low impedance to allow overcurrent protection devices to operate.
- To help limit the voltage caused by accidental contact of the site AC supply conductors with conductors of higher voltage.
- To help dissipate electrical surges and faults, to minimize the chances of injury from grounding system potential differences.
- To help dissipate the voltages caused by lightning.
- To help maintain a low potential difference among exposed metallic objects.

- To contribute to reliable equipment operation.
- To provide a common signal reference ground.

5.2 COMMON GROUNDING (EARTHING)

At a communications site, there **shall** be only one grounding (earthing) electrode system. For example, the AC power system ground, communications tower ground, lightning protection system ground, telephone system ground, exposed structural building steel, underground metallic piping, and any other existing grounding system **shall** be bonded together to form a single grounding electrode system. Underground metallic piping systems typically include water service, well castings located within 7.6 m (25 ft.) of the structure, gas piping, underground conduits, and underground liquefied petroleum gas piping systems. (ANSI T1.313-2003; ANSI T1.333-2001; ANSI T1.334-2002; IEC 61024-1-2, section 2.4.4; IEEE STD 1100-1999; NFPA 70-2005, Articles 250.58, 250.104, 250.106, 800.100, 810.21, and 820.100; and NFPA 780-2004, Section 4.14).

Interconnection to a gas line **shall** be made on the customer's side of the meter (NFPA 780-2004, Section 4.14.1.3). See Chapter 6, "Power Sources" for additional information on grounding and bonding requirements of power sources.

The objective of grounding and bonding system components to a single point is to minimize any difference of potential that may develop between individual components within the system and within the equipment site or area. To reach this objective a low-impedance internal single-point ground system is required for all communication equipment, support equipment, power systems, and other items and materials located within the building, shelter, room or area of the same building.

A **single point ground system** is defined as a single point, typically a master ground bus bar (MGB), within a shelter, equipment building or room, where all communications equipment, ancillary support equipment, antenna transmission lines, surge protection devices (SPDs), and utility grounds are bonded. The single point ground system must be effectively connected to a grounding electrode system as described in this chapter and in Chapter 4, "External Grounding (Earthing)".

The **system** is defined as all equipment required for proper communications system functionality at the site, and includes but is not limited to:

- Communications and support equipment
- Power systems
- Power distribution systems
- Voice, data and video circuits
- Antenna systems
- Global Positioning System (GPS)
- Surge protection devices
- Support components and material.

The **equipment site or area** is defined as the equipment building, shelter, room or area within another room where communications equipment or systems may be located and includes but is not limited to:

- Heating, ventilation and air conditioning (HVAC) systems
- Fire suppression systems
- Power distribution systems
- The building structure

5.3 GROUNDING (EARTHING) SYSTEM COMPONENTS AND INSTALLATION REQUIREMENTS

This chapter provides guidelines and requirements for establishing an internal grounding (earthing) system within a standalone equipment shelter, single-story building and multi-story building. The guidelines described in this chapter **shall** also be utilized for establishing an internal grounding system within an outdoor equipment vault, enclosure, or cabinet.

All new site design, development and construction should have a prime objective of establishing a single point internal ground system for all interconnected communication systems and networking systems located within the facility. To help achieve this objective, all utilities and telecommunication cables should be coordinated to enter the facility through a common wall, room, or area within the facility. The preferred configuration for a stand-alone equipment shelter is to have all utilities enter the structure through a common wall as close as practical to the transmission line entry port location. The main electrical service disconnect must be located on the shelter wall at the service entrance. For additional details on main service disconnect, see “Circuit Protection” on page 6-8.

If it is unavoidable that utilities enter an existing or new stand-alone equipment shelter at different locations, additional grounding is required to adequately dissipate high amounts of electrical energy from a lightning strike or possible power fault. The single point grounding location for this type of structure must be located next to the electrical service entrance location and as close as practical to the transmission line entry port location. See Figure 5-1 for a high level overview of the preferred internal grounding system design.

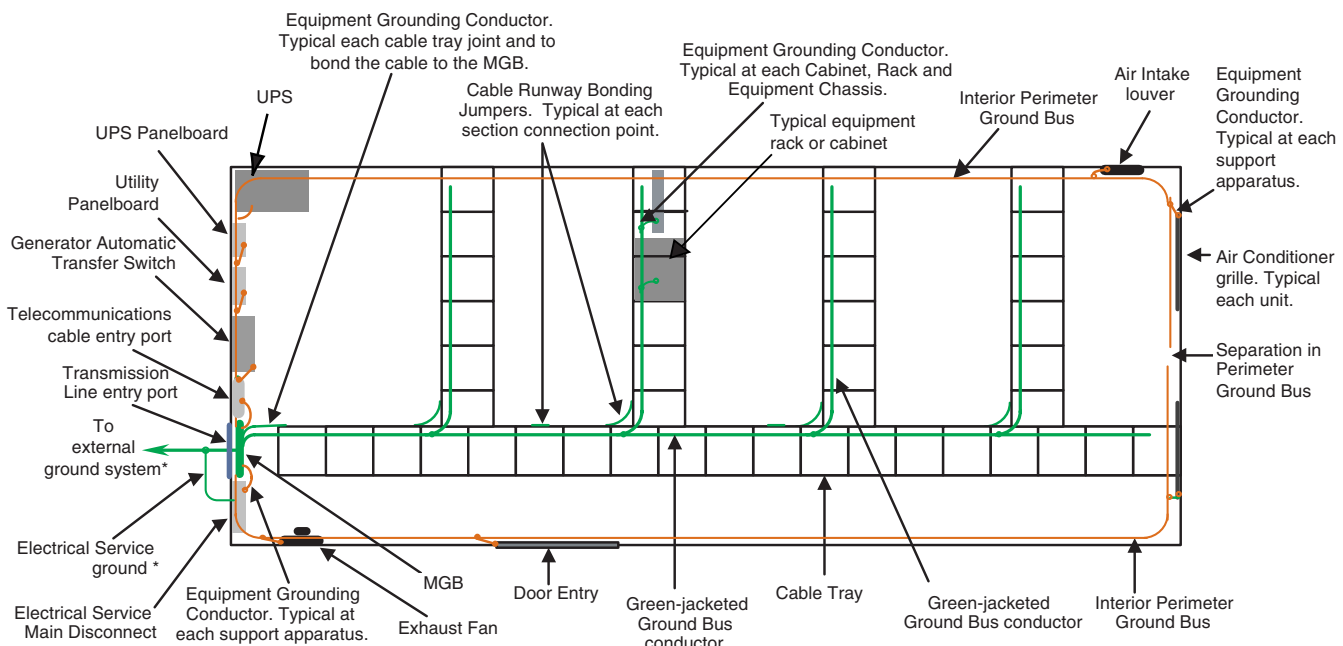

* NOTE: No exterior ground system conductors shown. Electrical service grounding electrode conductor must be bonded to external site ground system.

FIGURE 5-1 STAND-ALONE SHELTER WITH COMMON ENTRY LOCATION

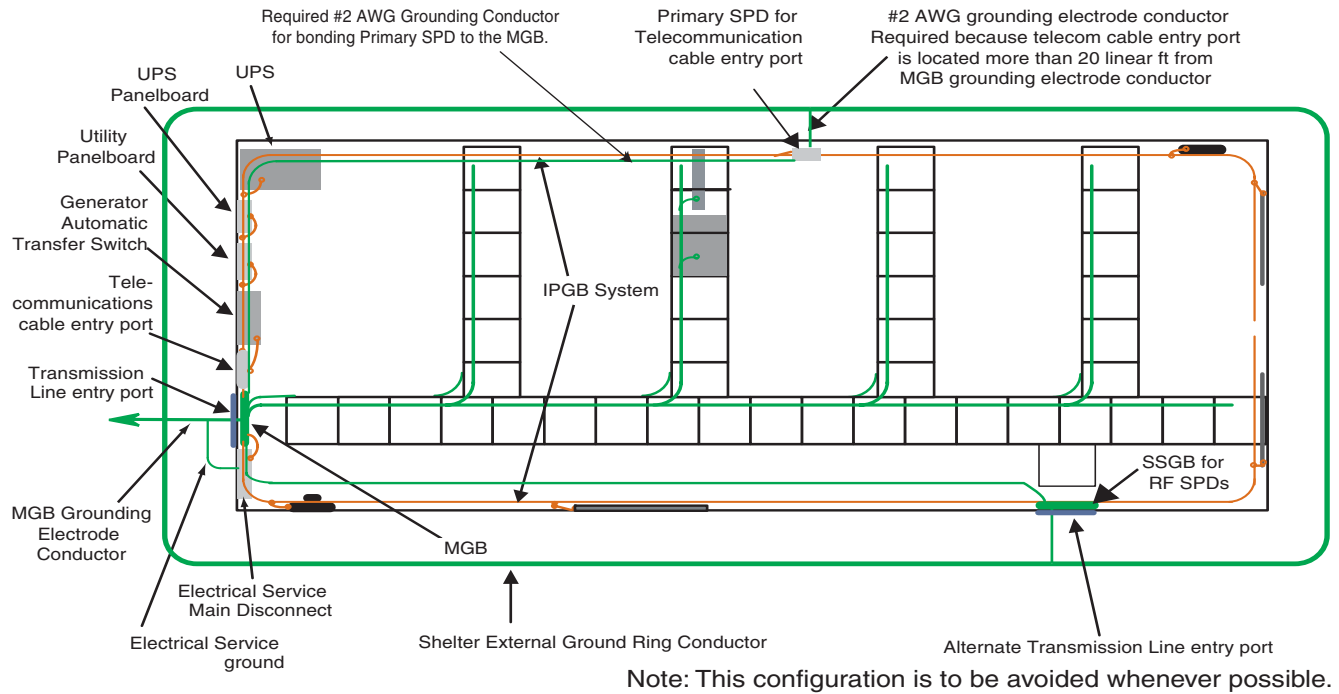

FIGURE 5-2 STAND-ALONE SHELTER WITH DIFFERENT ENTRY LOCATIONS

The preferred configuration for a single-story building is to have all utilities enter the structure through a common wall, room or adjacent rooms as close as practical to each other. The single point grounding location for this type of structure must be located at the utilities entrance location, preferably close to the building's electrical service (power) ground. See Figure 5-3 for an overview of the preferred internal grounding system design.

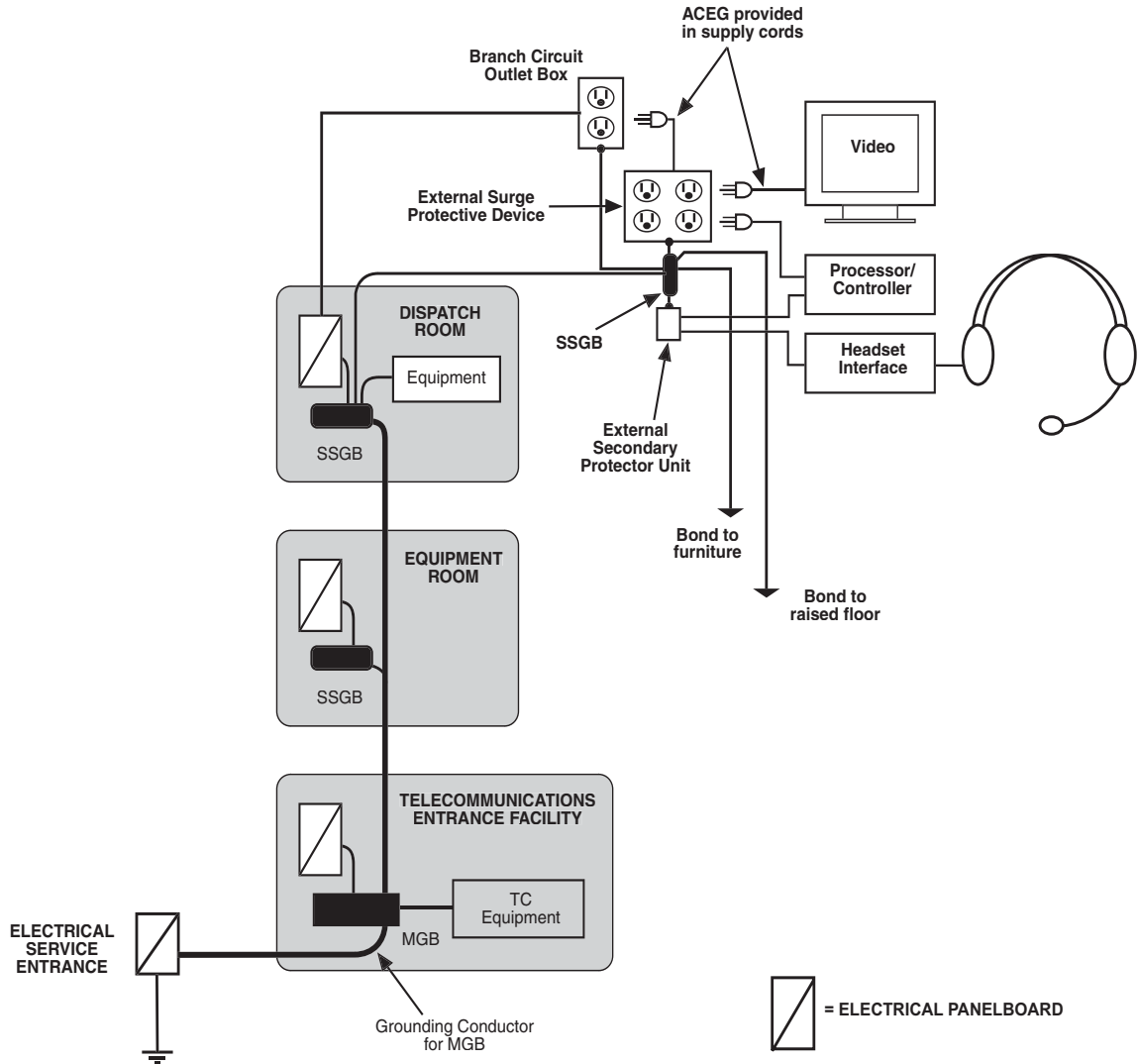

FIGURE 5-3 SINGLE-STORY BUILDING WITH COMMON ENTRY LOCATION

The preferred configuration for a multi-story building is to have all utilities enter the structure through a common wall, room or adjacent rooms as close as practical to each other. The single point grounding location for this type of structure must be located at the utilities entrance location preferably close to the building's electrical service (power) ground. See Figure 5-4 for an overview of the preferred internal grounding system design.

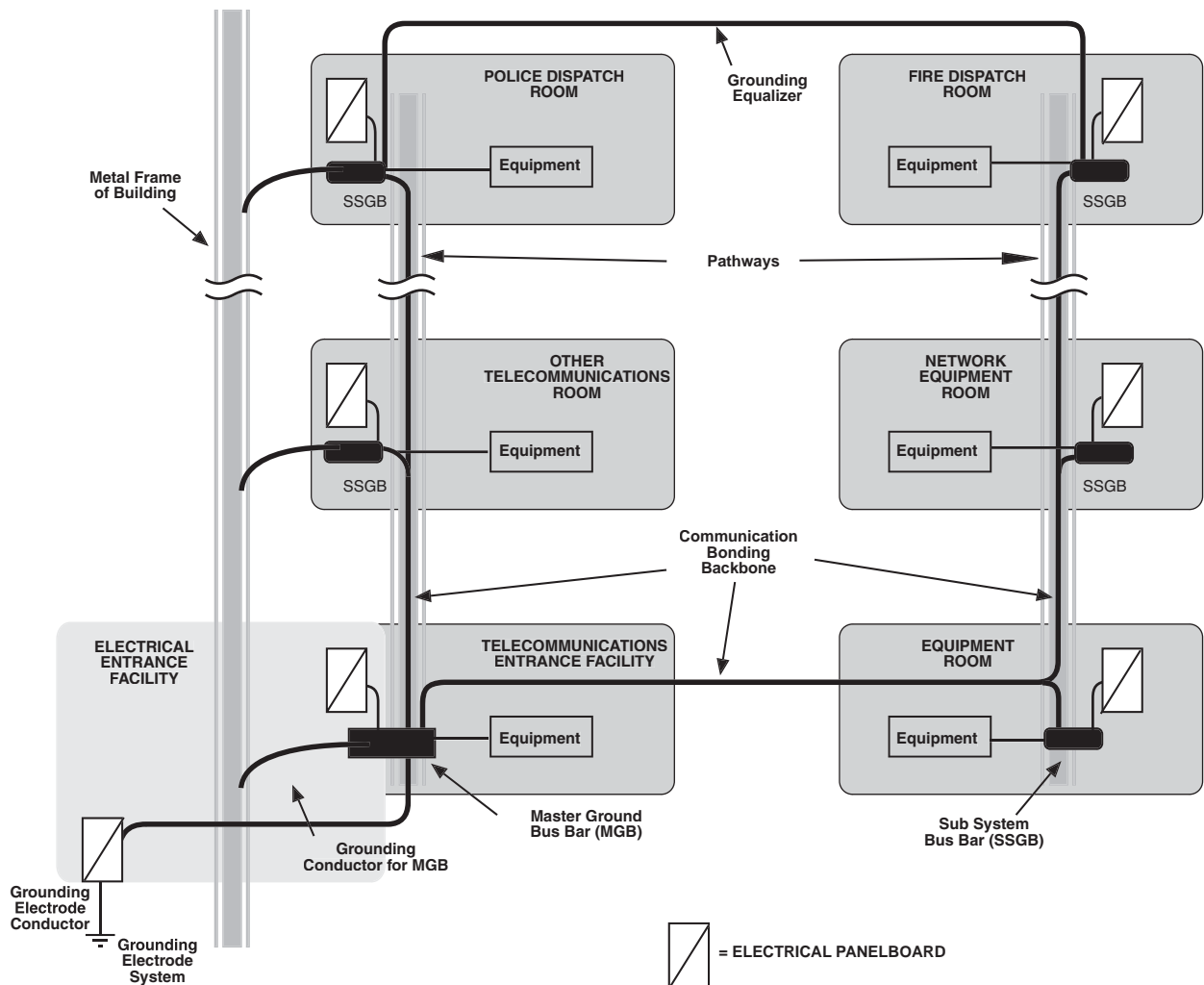

FIGURE 5-4 MULTI-STORY BUILDING WITH COMMON ENTRY LOCATION

An effective low-impedance internal grounding system can be achieved through the use of the components listed below, all of which must be effectively bonded together so that there is minimal difference in potential among them. Figure 5-5 shows the major components of a typical internal grounding system.

- Master Ground Bus Bar (MGB)
- Sub System Ground Bus Bar (SSGB)
- Rack Ground Bus Bar (RGB)
- Grounding conductors

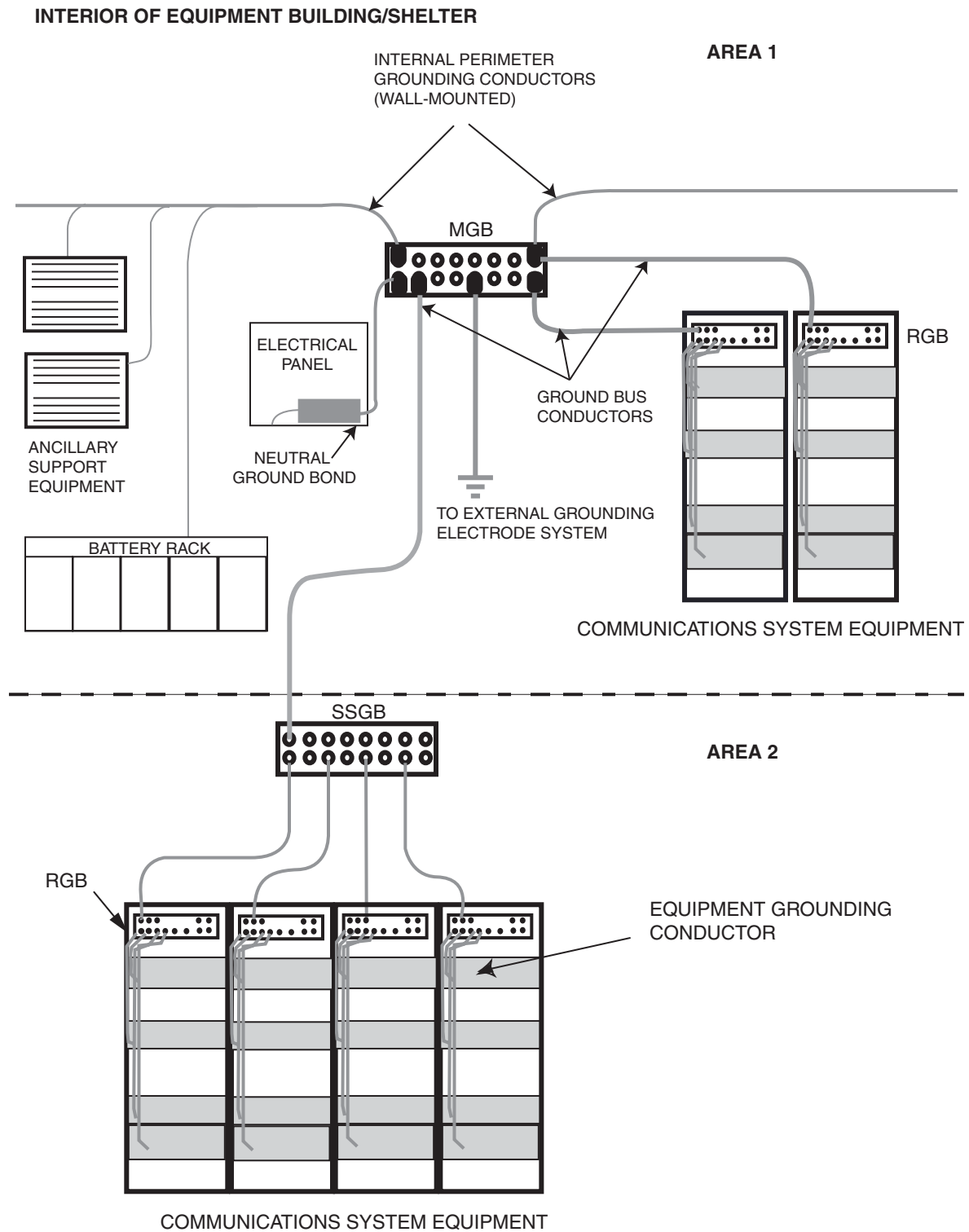

FIGURE 5-5 TYPICAL SINGLE-POINT INTERNAL GROUNDING SYSTEM

5.3.1 MASTER GROUND (EARTH) BUS BAR

The purpose of the master ground bus bar (MGB) is to provide a convenient internal grounding (earthing) termination point for the communication system and to serve as a dedicated extension of the site's common grounding electrode system. The MGB functions as the primary internal earth reference point for all equipment ground bus conductors, grounding conductors and communications equipment within the facility. Typically, there should only be a single MGB per building (ANSI-J-STD-607-A-2002 and ANSI T1.334-2002).

NOTE: Large buildings or campuses with multiple power feeds may require special design considerations that are beyond the scope of this document. Consultation with Motorola Engineering or with an engineering firm specializing in grounding system design is recommended in these instances.

A single MGB **shall** be installed for the communications system within a shelter, building, room or equipment area. The MGB should be located in close proximity to the electrical service entrance and installed with insulated mounting hardware. It may also be installed in an assembly of communications equipment cabinets as deemed necessary to ensure an effective bonding point for all equipment earthing conductors. A typical MGB with insulated mounting hardware is shown in Figure 5-6.

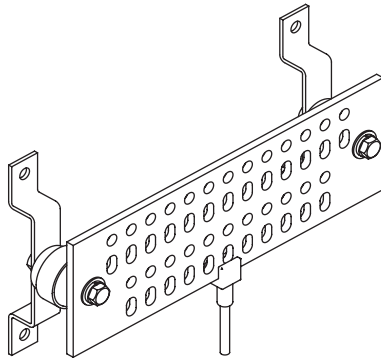

FIGURE 5-6 TYPICAL MASTER GROUND BUS BAR

5.3.1.1 MGB SPECIFICATIONS

The MGB **shall** be a copper bus bar with predrilled holes that provide for the use of standard-sized lugs. It is recommended that the bus bar be electroplated for reduced contact resistance. The MGB **shall** be sized in accordance with the immediate application and consideration should be given to future growth of the site. The MGB **shall** be listed by a nationally recognized testing laboratory (ANSI-J-STD-607-A-2002). See Table 5-1 on page 5-10 for additional specifications and requirements.

TABLE 5-1 MGB SPECIFICATIONS

Item	Specification
Material	Bare, solid Alloy 110 (99.9%) copper bus bar or plate of one piece construction. May be electrotin-plated.
Minimum Dimensions NFPA 70-2005, Article 250.64)	Height: 50.8 mm (2 in.) Thickness: 6.35 mm (0.25 in.) Length: Variable to meet the application requirements and allow for future growth. 305 mm (12 in.) is recommended as the minimum length.
Mounting brackets	Must be suitable for the application.
Insulators	Polyester Fiberglass 15 kV minimum dielectric strength Flame resistant per UL 94 VO classification
Conductor mounting hole: Number and Dimensions	Dependent on number of conductors to be attached Holes should be 11 mm (0.4375 in.) minimum on 19 mm (0.75 in.) centers to permit the convenient use of two-hole lugs
Method of attachment of grounding electrode conductor.	Exothermic welding Irreversible crimp connection Other suitable irreversible crimp connection process

NOTE: A single properly installed integrated cable entry port of solid copper construction, electrically continuous between the interior and exterior of the structure through which it is mounted and with adequate surface area for proper termination of the internal grounding conductors, may be used as the MGB and external ground bus bar **only** if the site is properly designed for such a configuration. See “Grounding (Earthing) Electrode System Component and Installation Requirements” on page 4-7 for additional information on the external ground bus bar (EGB). Figure 5-7 shows an integrated cable entry port.

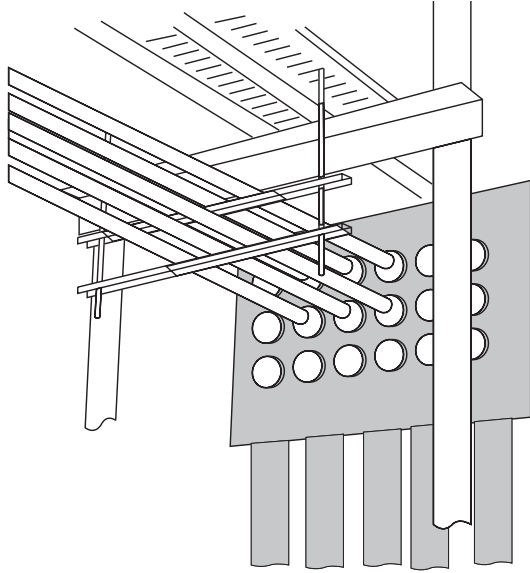

NOTE: Coaxial ground kits are located within the integrated panel and are not shown.

FIGURE 5-7 INTEGRATED CABLE ENTRY PORT BULKHEAD (OUTSIDE AND INSIDE VIEWS)

5.3.1.2 MGB LOCATION

Whenever practical, the MGB should be located within 610 mm (24 in.) of the transmission line entry into the building, equipment shelter, room, vault, enclosure or cabinet, preferably on the same wall or at the same entry location as the electrical service and the telecommunications cables. This configuration allows for a single point ground window to be established for the internal grounding (earthing) system. Figure 5-8 shows an example of this configuration for a stand-alone equipment shelter.

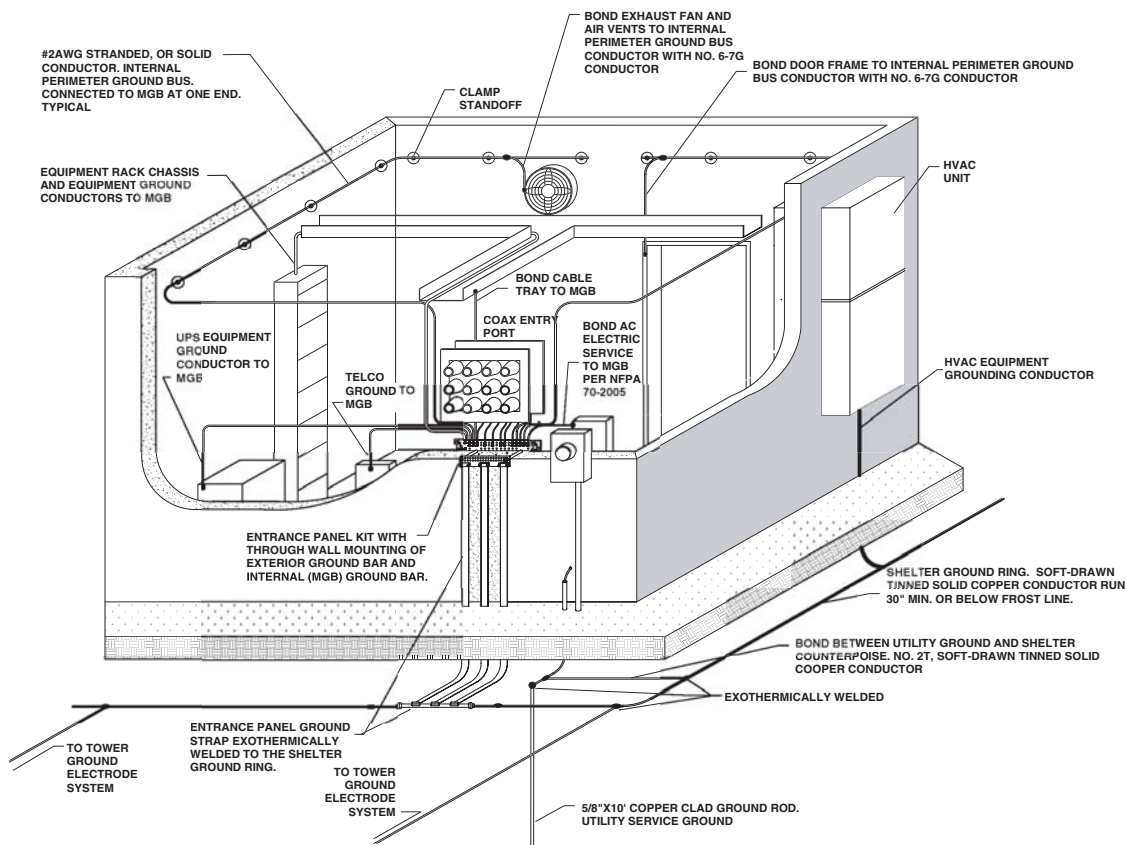

FIGURE 5-8 STAND-ALONE SHELTER WITH COMMON ENTRY LOCATION

The MGB must be insulated from its support structure just below the point where the transmission lines enter the facility, shelter or enclosure. In facilities or shelters where the transmission lines enter through a wall at floor level or through conduits within the floor or ceiling, the MGB should be located on the wall or floor immediately adjacent to the transmission lines entry point. In all cases, the MGB must be located in a position that provides the shortest and straightest routing of the grounding conductors to the grounding electrode system.

In facilities where the transmission lines, the electrical service and the telecommunication cables enter at different locations, the MGB must be located as described within this chapter. In all cases the transmission lines, the telecommunication cables and the electrical service **shall** be effectively bonded back to the MGB, and the MGB **shall** be effectively bonded back to the grounding electrode system as described within this chapter.

5.3.1.3 BONDING: MGB-TO-GROUNDING (EARTHING) ELECTRODE SYSTEM

The installation specifications of the MGB and the acceptable methods for bonding the MGB to the site's grounding (earthing) electrode system are listed below. The following requirements are from ANSI-J-STD-607-A-2002 and other standards as noted.

- The MGB **shall** be insulated from its support structure. A minimum 51 mm (2 in.) separation from the supporting surface is recommended to allow access to the rear of the bus bar.

- The MGB grounding conductor **shall** extend from the MGB to the grounding electrode system with the shortest and straightest routing possible (ANSI T1.334-2002).
- When the communications system is located in a large or multi-story building, the MGB grounding conductor **shall** extend from the MGB to the service equipment (power) ground with the shortest and straightest routing possible.
- The MGB grounding conductor **shall** be of a copper material and may be insulated. If the conductor is insulated, the jacket **shall** be listed for the application as described within this chapter (ANSI T1.334-2002).
- When bonding back to an external grounding electrode system, it is strongly recommended that the MGB grounding conductor be multi-stranded, bare, individually tinned, copper.
- The MGB grounding conductor **shall** be 35 mm² csa (#2 AWG) minimum, and **shall not** be smaller than the largest ground bus conductor or equipment grounding electrode conductor installed within the internal grounding system (ANSI T1.334-2002, and NFPA 70-2005, Article 250.64(F)).
- The MGB grounding conductor **shall** be secured to the MGB by exothermic welding, listed compression two-hole lug, or irreversible compression-type connection device (ANSI T1.334-2002).
- The MGB grounding conductor **shall** be bonded to the external grounding electrode system with an exothermic weld or a listed irreversible compression device (ANSI T1.334-2002).
- Where exposed to physical damage, the MGB grounding conductor **shall** be protected and the conductor or its enclosure **shall** be securely fastened to the surface on which it is carried (NFPA 70-2005, Article 250.64(B)).
- The MGB grounding conductor should be free of any splices. Should a splice in the grounding electrode conductor become necessary, splicing **shall** be permitted only by listed irreversible compression-type connectors or by the exothermic welding process (NFPA 70-2005, Article 250.64(C)).
- The MGB grounding conductor **shall** be run to the grounding electrode system in a direct manner with no sharp bends or narrow loops. The grounding conductor bend angles (included angle) **shall not** be less than 90 degrees nor have a bending radius of less than 203 mm (8 in.) (ANSI T1.313-2003). When routing the MGB grounding conductor through a perimeter wall to the external grounding electrode system, the grounding conductor should be routed through the wall in a PVC or flexible non-metallic conduit sleeve at a 45 degree angle towards the grounding electrode system. See Figure 5-9 for an example of MGB grounding electrode conductor routing.

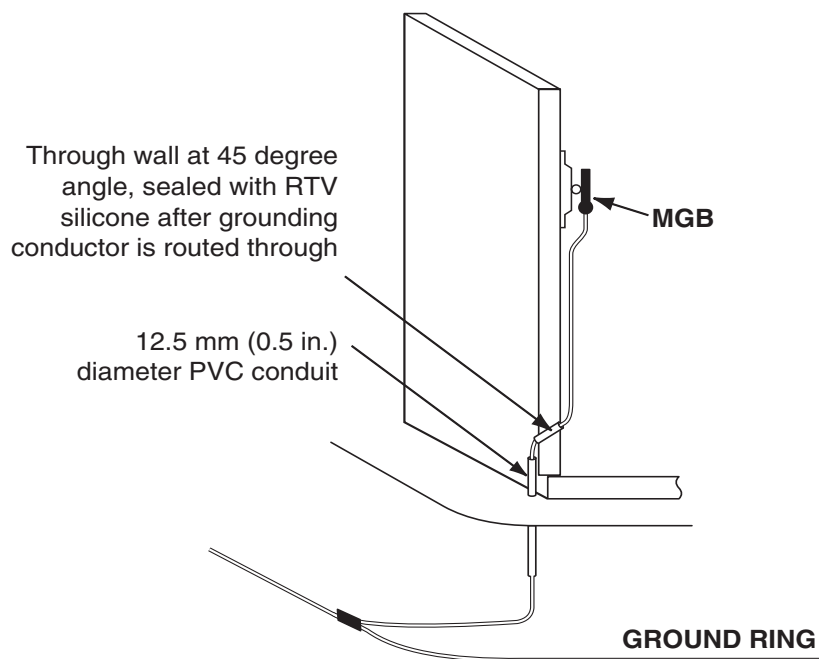

FIGURE 5-9 ROUTING OF MGB GROUNDING ELECTRODE CONDUCTOR

- The MGB grounding conductor should not be placed in ferrous metallic conduit. If local building codes require metallic conduit or sleeves, the grounding conductor **shall** be bonded to each end of the conduit using a listed grounding bushing or a bonding jumper of the same size, or coarser than, the required enclosed grounding electrode conductor (ANSI T1.334-2002, ANSI T1.313-2003 and NFPA 70-2005, Article 250.64(E)).
- Unless both ends of the grounding conductor are clearly visible, the conductor must be clearly labeled on both ends (ANSI T1.333-2001). In large and multi-story commercial buildings, each communication grounding and bonding conductor should be labeled as close as practicable to its point of termination in a readable location. The label **shall** be nonmetallic and should include the following information shown below (ANSI-J-STD-607-A-2002).

IF THIS CONNECTOR OR CABLE IS LOOSE OR MUST BE
REMOVED, PLEASE CALL THE BUILDING
TELECOMMUNICATIONS MANAGER

5.3.1.4 ACCEPTABLE GROUNDING (EARTHING) OF THE MGB

The following are considered acceptable for use as a grounding (earthing) electrode system at a communications system facility:

- In stand-alone building or equipment shelter, the MGB **shall** be bonded back to the common external grounding electrode system ground ring conductor (ANSI T1.334-2002 and ANSI T1.313-2003). See Chapter 4, “External Grounding (Earthing),” for external grounding electrode system requirements.

- In a small, large or multi-story building, the MGB grounding conductor **shall** extend from the MGB to the service equipment (power) grounding electrode system (ANSI-J-STD-607-A-2002).
- Where any of the following exist at a building or structure, they **shall** be effectively bonded together to form a common grounding electrode system and the MGB may bond to any point on this grounding electrode system: a metallic underground water pipe, the metal frame of the building or structure, concrete-encased electrodes, a ground ring conductor encircling the building or structure, rod or pipe electrodes and plate electrodes. (See NFPA 70-2005, Article 250.50 and 250.52 for additional information.) See Chapter 4, “External Grounding (Earthing),” for external grounding electrode system bonding requirements.

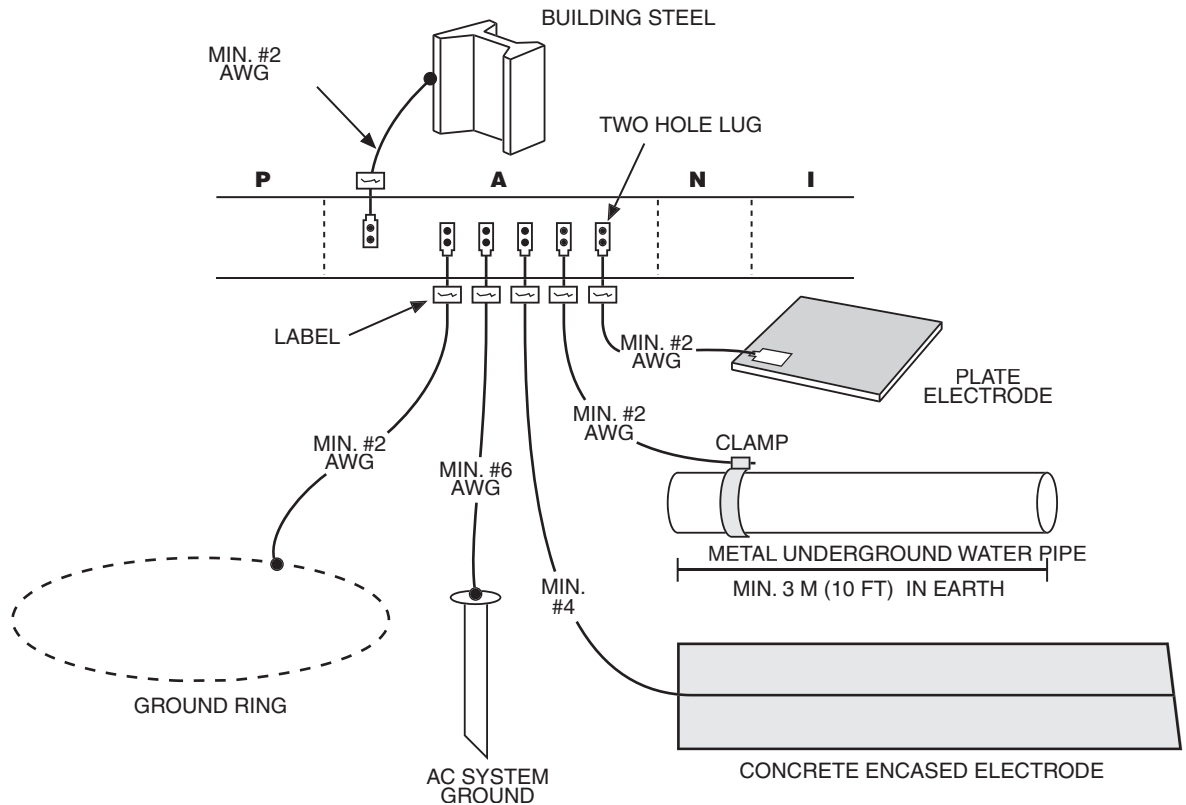

FIGURE 5-10 TYPES OF ACCEPTABLE GROUNDING ELECTRODE SYSTEMS

5.3.2 SUB SYSTEM GROUND (EARTH) BUS BAR

A Sub System Ground Bus Bar (SSGB) may be installed within a generator or power distribution room, a communications subsystem equipment room or area separate from, but associated with, the main communications equipment room or area and located within the same building as the MGB. In some applications the SSGB may be referred to as a telecommunications ground bus bar (TCGB), an isolated zone ground bus bar (IZGB), an ancillary ground bus bar (AGB), a logic ground bus bar (LGB), a frame ground bus bar (FGB), a telephone cable ground bus bar (TCGB), or an equipment reference ground bus bar (ERGB).

The SSGB provides a single termination point for all internal ground bus conductors, internal perimeter ground bus conductors, or equipment grounding conductors within a communications subsystem equipment room or area as defined herein. By having all equipment and ancillary support apparatus within the communications system equipment area bonded to a SSGB, differences in potential between communications system components are minimized and the probability of personal injury, system failure, or equipment damage greatly reduced.

A SSGB **shall not** be used when the associated equipment is located in a separate shelter or building, even if the shelter or buildings are adjacent to one another. A shelter added as a permanent attachment to an original building or shelter, which receives AC power from the same electrical service as the original building or shelter, is not considered a separate shelter or building for the purpose of this paragraph. See Figure 5-11 for an example of some acceptable SSGB configurations.

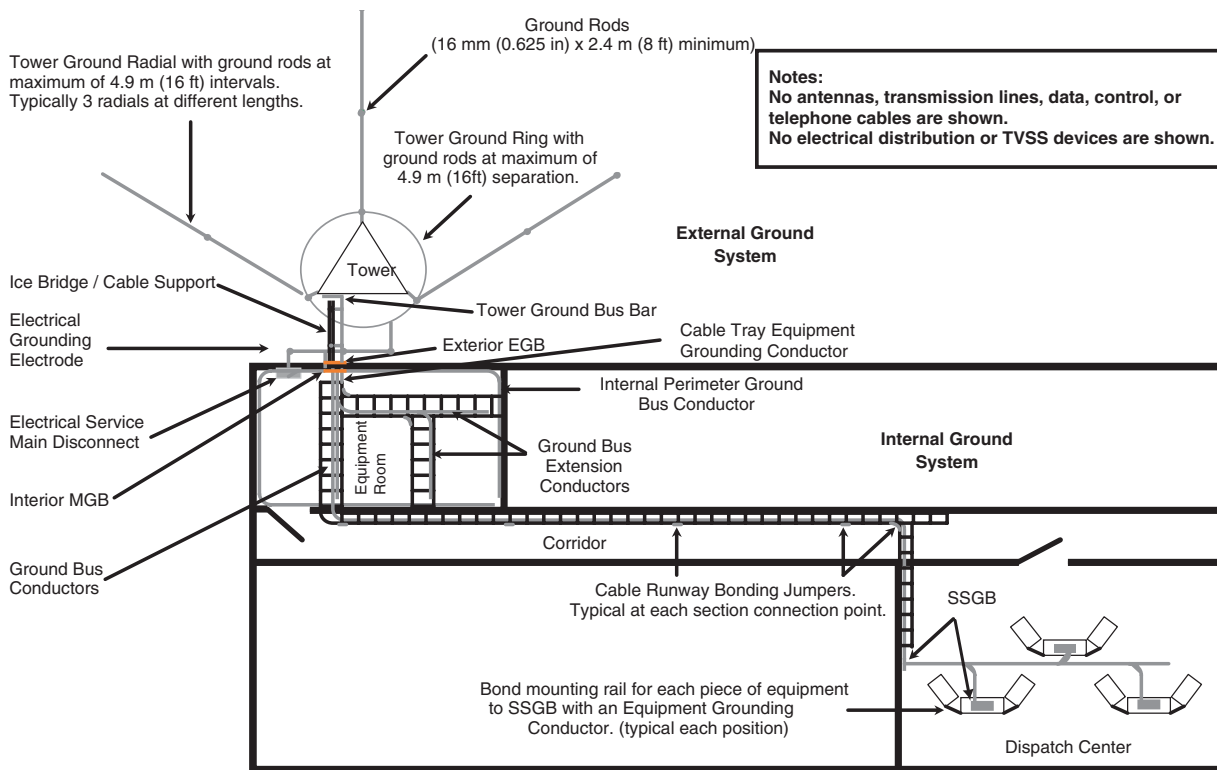

FIGURE 5-11 EXAMPLE OF SSGB CONFIGURATION

A SSGB may be installed in an assembly of communications equipment cabinets or at a network operator position as necessary to provide an effective bonding point for all equipment grounding conductors. Installation of a single rack, cabinet or chassis within a room or area does not require the installation of a SSGB as defined in this section, though one may be installed if desired.

5.3.2.1 SSGB SPECIFICATIONS

The SSGB **shall** be a copper bus bar with predrilled holes that provide for the use of standard sized lugs. It is recommended that the bus bar be electrotin plated for reduced contact resistance. The SSGB **shall** be sized in accordance with the immediate application and consideration should be given to future growth of the site. The SSGB **shall** be listed by a nationally recognized testing laboratory when it is placed within a building facility (ANSI-J-STD-607-A-2002) and it should be listed when placed within other type equipment locations. See Figure 5-12 for a typical layout of conductor mounting holes and see Table 5-2 for additional specifications and requirements.

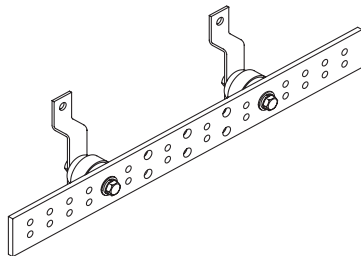

FIGURE 5-12 EXAMPLE OF SSGB

TABLE 5-2 SSGB Specifications

Item	Specification
Material	Bare, solid Alloy 110 (99.9%) copper bus bar or plate of one piece construction. May be electrotin-plated.
Minimum Dimensions (ANSI-STD-J-607-A-2002)	Height: 50.8 mm (2 in.) Thickness: 6.35 mm (0.25 in.) Length: Variable to meet the application requirements and allow for future growth. 305 mm (12 in) is recommended as the minimum length.
Mounting brackets	Must be suitable for the application.
Insulators	Polyester Fiberglass 15 kV minimum dielectric strength Flame resistant per UL 94 VO classification
Conductor mounting holes	Dependent on number of conductors to be attached. Holes should be 11 mm (0.4375 in.) minimum on 19 mm (0.75 in.) centers to permit the convenient use of two-hole lugs.
Method of attachment of grounding conductor.	Exothermic welding Irreversible crimp connection Other suitable irreversible crimped 2-hole lug

5.3.2.2 LOCATION

When used, the SSGB **shall** be located within the communications equipment room or area at the point where it is most convenient to terminate all ground (earth) bus conductors.

Although not recommended, and not a good design practice, occasionally exterior transmission lines and other telecommunication cables must enter an area served with a SSGB (i.e., not served by the MGB). In these instances special design criteria must be considered to ensure that potential differences between the location of the SSGB and the MGB are minimized. For these applications, additional surge suppression devices may be required on any interconnecting power, data, audio, telephone or telephone type circuits, even though they are routed within the same building. If the SSGB serving a transmission line or other communication cable entry point is located more than 6.1 linear metres (20 linear feet) from the MGB's grounding electrode system (the point where the MGB grounding electrode conductor enters the earth), the SSGB **shall** have a properly sized grounding electrode conductor installed directly to the site's common grounding electrode system with the shortest and straightest routing possible (NFPA 70-2005, Articles 800.100, 810.21, 820.100 and 830.100). Consultation with Motorola Engineering or other engineering firm is suggested in these instances.

For communication sites installed in large or multi-story commercial buildings, a SSGB **shall** be located inside each communications equipment room. A SSGB **shall** be installed as close to the panelboard as is practicable, with adequate clearance around it to comply with applicable local electrical codes. Where a panelboard for the communications equipment is not installed within the room, the SSGB should be located near the communication bonding backbone conductor at a location that allows the shortest routing of the grounding conductors. Multiple SSGBs may also be installed within the same room to aid in minimizing bonding conductor length and terminating space. Multiple SSGBs within a room **shall** be bonded together with a conductor of the same size as the communication bonding backbone conductor, with splice bars, or as described within this chapter. (See ANSI-J-STD-607-A-2002 for additional information.) See Figure 5-41 on page 5-67.

5.3.2.3 BONDING THE SSGB TO THE GROUNDING (EARTHING) SYSTEM

The installation specifications for the SSGB and the acceptable methods for bonding the SSGB back to the site's grounding system are listed below. The following requirements come from ANSI-J-STD-607-A-2002 and other standards as noted.

- The SSGB **shall** be insulated from its support structure. A minimum 51 mm (2 in.) separation from the supporting surface is recommended to allow access to the rear of the bus bar.
- The SSGB grounding conductor **shall** be of a copper material and may be insulated. If the conductor is insulated, the jacket **shall** be listed for the application as described within this chapter (ANSI T1.334-2002).
- The SSGB grounding conductor **shall** be 35 mm² csa (#2 AWG) or coarser, and **shall not** be smaller than the largest ground bus conductor or equipment grounding conductor bonded to it (ANSI T1.334-2002 and NFPA 70-2005, Article 250.64(F)).
- The SSGB grounding conductor **shall** be secured to the SSGB by exothermic welding, listed compression two-hole lug, or irreversible compression-type connection device (ANSI T1.334-2002).
- The SSGB grounding conductor should be free of any splices. Should a splice in the grounding conductor become necessary, splicing is permitted only by listed irreversible compression-type connectors or by exothermic welding (NFPA 70-2005, Article 250.64(C)).

- The SSGB grounding conductor **shall** be bonded to the MGB, a collocated SSGB, or to a communication bonding backbone conductor as described within this chapter.
- When its required that the SSGB be bonded back to the external grounding electrode system, it is strongly recommended that the SSGB grounding electrode conductor be multi-stranded, bare, individually tinned, copper.
- The SSGB grounding electrode conductor **shall** be bonded back to the external grounding electrode system with an exothermic weld or a listed irreversible compression device (ANSI T1.334-2002).
- SSGB grounding electrode conductors located in areas with the potential for physical damage **shall** be protected and the conductor or its enclosure **shall** be securely fastened to the surface on which it is carried (NFPA 70-2005, Article 250.64(B)).
- The SSGB grounding electrode conductor **shall** be run to the grounding electrode system in a direct manner with no sharp bends or narrow loops. The grounding conductor bend angles (included angle) **shall not** be less than 90 degrees nor have a bending radius of less than 203 mm (8 in.) (ANSI T1.313-2003). See Figure 5-13.

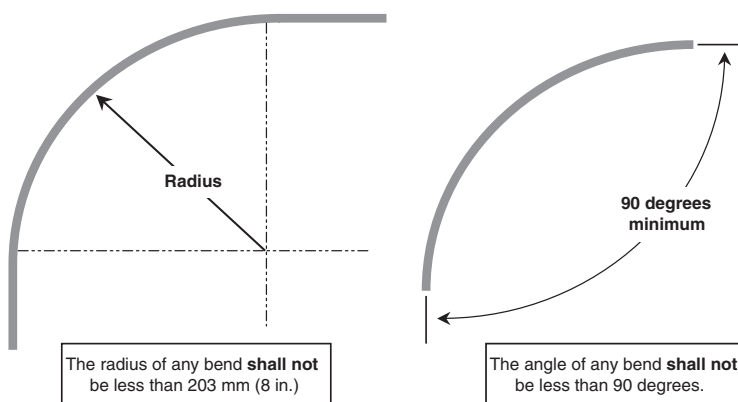

FIGURE 5-13 ACCEPTABLE GROUND CONDUCTOR BENDING

- When routing the SSGB grounding conductor through a perimeter wall to the external grounding electrode system, the grounding conductor should be routed through the wall in a PVC or flexible non-metallic conduit sleeve at a 45 degree angle towards the grounding electrode system.
- The SSGB grounding conductor should not be placed in ferrous metallic conduit. If local building codes require metallic conduit or sleeves, the grounding electrode conductor **shall** be bonded to each end of the conduit using a listed grounding bushing or a bonding jumper of the same size, or coarser than, the required enclosed grounding electrode conductor (ANSI-J-STD-607-A-2002, ANSI T1.334-2002, ANSI T1.313-2003 and NFPA 70-2005, Article 250.64(E)).
- Unless both ends of the grounding conductor are clearly visible, the conductor **shall** be clearly labeled on both ends (ANSI T1.333-2001). In large and multi-story commercial buildings, each communication grounding and bonding conductor should be labeled as close as practicable to its point of termination in a readable location. The label **shall** be nonmetallic and should include the information shown below (ANSI-J-STD-607-A-2002).

IF THIS CONNECTOR OR CABLE IS LOOSE OR MUST BE
REMOVED, PLEASE CALL THE BUILDING
TELECOMMUNICATIONS MANAGER

5.3.3 RACK GROUND (EARTH) BUS BAR

A rack ground bus bar (RGB) may be installed within an equipment rack or cabinet to provide a termination point for individual equipment grounding conductors for equipment installed within that rack or cabinet. The rack or cabinet grounding conductor(s) may also terminate on the RGB. Installations of a cabinet or assembly of cabinets comprising one enclosure that contains a complete system may have a single RGB installed serving as the system ground bus.

5.3.3.1 SPECIFICATIONS AND BONDING REQUIREMENTS

The RGB **shall** be made of solid copper, copper alloy, tinned copper, or tinned steel. The RGB **shall** be sized appropriately for the application and **shall** be sized equivalent to no less than 35 mm² csa (#2 AWG) copper conductor. The bus bar **shall** have a suitable number of drilled 11 mm (0.4375 in.) holes to accommodate the required number of connections.

The installation specifications for the RGB and the acceptable methods for bonding the RGB back to the site's grounding system are listed below.

- The RGB **shall** be securely mounted on suitable standoff hardware to maintain a separation of dissimilar metals and to facilitate conductor attachment. The use of standoff insulators may be suitable for this purpose.
- The RGB may be directly mounted/bonded to the rack or cabinet frame only if doing so allows adequate space for attaching grounding conductors and does not create a dissimilar metals reaction.
- The RGB grounding conductor **shall** be made of copper and may be insulated. If the conductor is insulated, the jacket **shall** be listed for the application as described within this chapter (ANSI-J-STD-607-A-2002 and ANSI T1.334-2002).
- The RGB grounding conductor **shall** be a minimum 35 mm² csa (#2 AWG) or coarser, in conductor size.
- The RGB grounding conductor should be secured to the RGB by listed two-hole compression lug. See “Bonding to the MGB, SSG And RGB” on page 5-36.
- The RGB grounding conductor should be free of splices. Should a splice in the grounding conductor become necessary, splicing **shall** be permitted only by listed irreversible compression-type connectors or by exothermic welding (NFPA 70-2005, Article 250.64(C)).
- The RGB grounding conductor **shall** be bonded back to the MGB, a co-located SSG, an equipment ground bus conductor, or an equipment ground bus extension conductor as described within this chapter.
- At stand-alone cabinet or cabinet assembly installations where no MGB or SSG is installed, the RGB **shall** be bonded to the electrical service grounding electrode system or conductor with an exothermic weld or a listed irreversible compression-type connection device.

5.3.4 GROUNDING (EARTHING) CONDUCTORS

All interior grounding (earthing) and bonding conductors **shall** be insulated stranded copper conductors unless otherwise specified within this chapter. Insulated conductors **shall** be listed for the space in which they are intended to be placed. The jacket **shall** be green, green with a yellow stripe or properly marked with a distinctive green coloring, green tape or green adhesive label (NFPA 70-2005, Article 250.119(A) and ANSI-J-STD-607-A-2002).

NOTE: Conductors installed within a plenum **shall** be compliant with NFPA 70-2005, Article 300.22 and cables installed within Information Technology rooms **shall** be compliant with NFPA 70-2005, Article 645. Ground conductors **shall** have an approved covering (insulation) or may be bare. When bare conductors are used they **shall** be solidly supported on suitable standoff insulators at intervals of no more than 610 mm (24 in.). These conductors **shall not** be in contact with metallic surfaces or other conductors unless intended to be bonded to these surfaces or conductors. These conductors **shall** be covered or jacketed upon exit from the plenum area and may be spliced at this point using an approved splicing method described within this chapter.

All grounding conductors **shall** be installed and routed so that personal safety is not compromised and that all equipment is serviceable. The following requirements **shall** apply:

- **Length:** conductors **shall** be no longer than required to achieve their purpose and **shall** be installed and routed in a professional and workmanlike manner.
- **Support:** conductors **shall** be secured or attached to surfaces as required to ensure they do not become damaged or disconnected. Conductors **shall** be secured in a manner that permits associated equipment to be easily serviced. Conductors **shall** be secured at no greater than 914 mm (3 ft.) intervals.
- **Protection:** conductors installed in areas where they may be subjected to damage **shall** be sleeved in electrical non-metallic tubing, or other conduit, that is securely attached to the surface over which it is routed.
 - In locations where metallic tubing or conduit is required for adequate protection, the conductor(s) routed through the metallic tubing or conduit must be effectively bonded to each end of the conduit using suitable listed means and devices (NFPA 70-2005, Articles 250.92(A)(3) and 250.64(E)).
 - When ground conductor tap joints are used, they **shall** be properly insulated as to prevent the bare conductor or connection device from making incidental contact with metallic surfaces.
- **Routing:**
 - At points where conductors are routed through holes within metallic surfaces, the surfaces **shall** be suitably protected with grommets or other material to minimize damage to the conductor or insulation.
 - Conductors **shall** be routed toward the MGB, SSGB, or RGB. Connections to bus conductors **shall** always be made with the tap conductors routed toward the MGB, SSGB, or RGB. See Figure 5-1 on page 5-4 and Figure 5-17 on page 5-24.
 - At points where conductors must pass through a hole in a metallic surface and the hole is slightly larger than the conductor, the conductor **shall** be bonded to the metallic surface through which it passes. If the hole or opening is much larger than the conductor and is intended to accommodate several conductors, the conductor is not required to be bonded. See Figure 5-14 on page 5-22.
 - Ground bus conductors may be routed within cable trays, on the outside of cable trays where suitable support is provided, or along equipment platforms. See Figure 5-15 and Figure 5-16 on page 5-23.
 - Equipment grounding conductors **shall** be installed along the rack rail or other suitable support medium leading to the cable tray system or ground bus conductor.

- Ground bus conductors **shall** be routed using the shortest possible routes. They may extend into an adjoining subsystem equipment area and may serve as the grounding conductor for a SSGB or a RGB. These ground bus conductors may have ground bus extension conductors to provide a ground bus within cross section segments of a cable tray system. These ground bus extension conductors **shall** be of the same specification as the ground bus conductor and **shall** be routed with all connections to the ground bus conductor pointed in the direction of the MGB or SSGB.

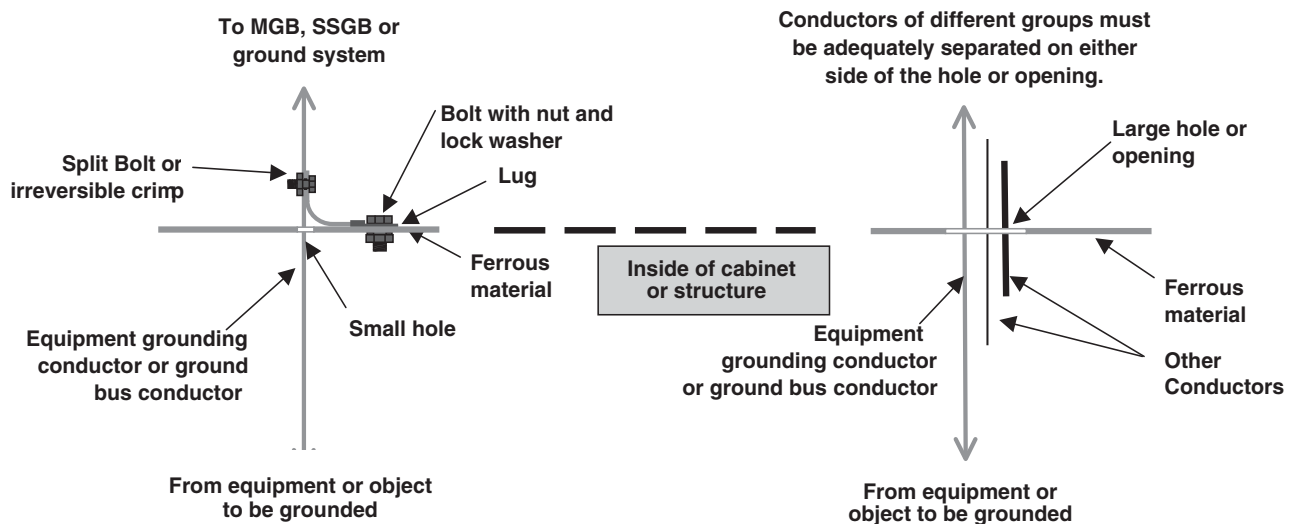

FIGURE 5-14 CONDUCTOR ROUTING THROUGH HOLES OR OPENINGS IN METALLIC SURFACES

- Bending radius:** Ground bus conductors of all sizes **shall** maintain a minimum bending radius of 203 mm (8 in.). The angle of any bend **shall not** be less than 90 degrees (NFPA 780-2004, Section 4-9.5). See Figure 5-13 on page 5-19.
- Separation:**
 - All ground conductors **shall** be separated a minimum of 51 mm (2 in.) from conductors of other cable groups as defined in “Cable Trays” on page 3-18, and “Cable Separation and Grouping within Racks and Cabinets” on page 9-12. Grounding conductors may come in contact with other cable groups if they cross at a 90 degree angle and the crossing angle can be maintained. An exception may be when conductors are grouped together to enter or exit a cabinet or enclosure. Grouping only at this point is acceptable, provided the conductors are suitably separated on either side of the opening.
 - To minimize potential inductive effects when routing a grounding conductor through ferrous material, the conductor **shall** be separated from the ferrous material by a distance of at least 51 mm (2 in.) where achievable, or the grounding conductor **shall** be effectively bonded to the ferrous material. See Figure 5-14.

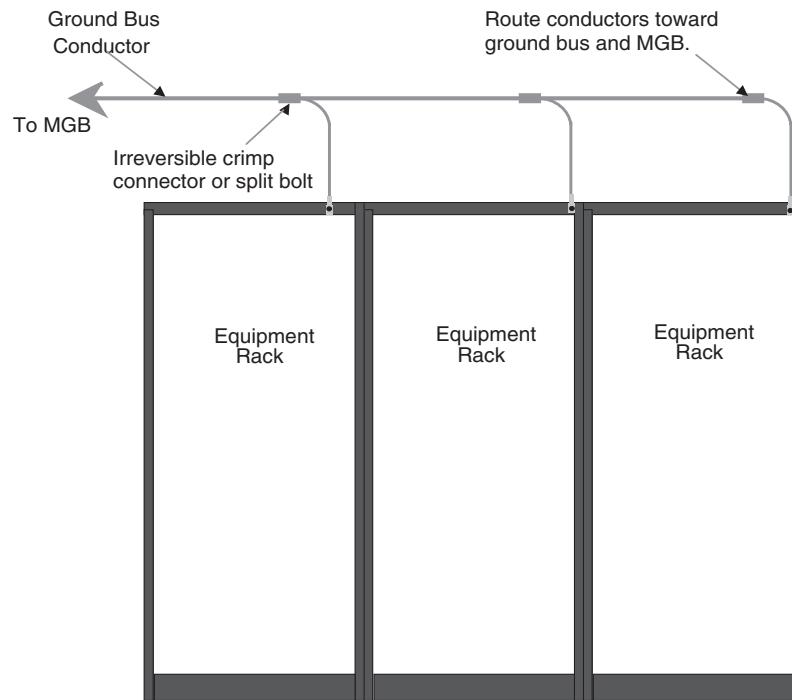

FIGURE 5-15 GROUND BUS CONDUCTOR ROUTING

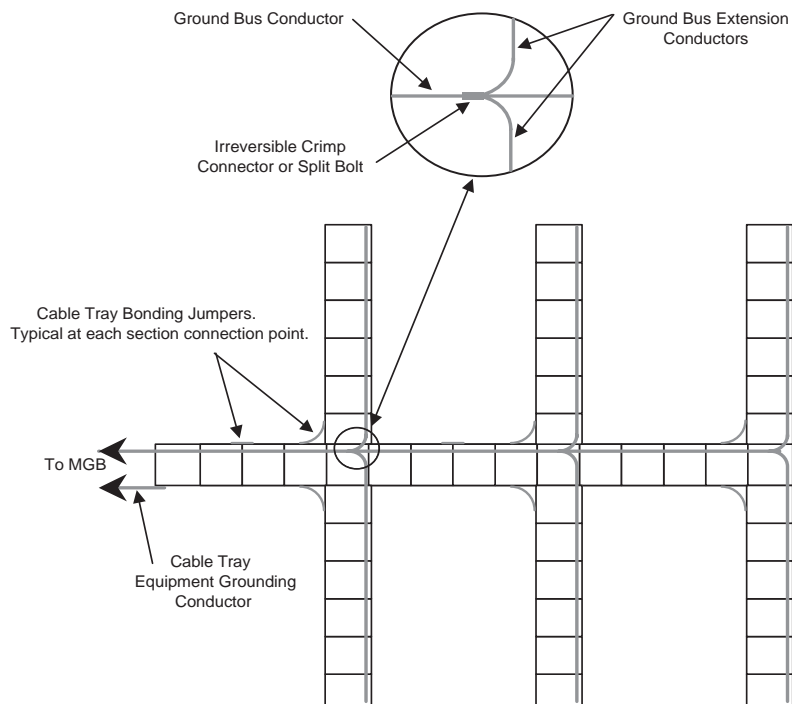

FIGURE 5-16 GROUND BUS CONDUCTOR ROUTING - TOP VIEW OF CABLE TRAYS

5.3.5 GROUND (EARTH) BUS CONDUCTORS

Ground (earth) bus conductors interconnect the MGB, SSGB, RGB and the equipment grounding conductor with the cabinets, racks or individual system or subsystem components. The end of the conductor opposite the MGB or SSGB typically remains unterminated, although this end of the conductor may be terminated to a cabinet, rack, individual system component or RGB.

Ground bus conductors typically originate at the MGB and radiate throughout the equipment area generally within the cable tray system. These conductors may extend into an adjoining subsystem equipment area and may serve as the grounding conductor for a SSGB, or RGB. Ground bus conductors **shall** be bonded to the MGB, SSGB, or RGB using methods described within this chapter.

Ground bus conductors may have ground bus extension conductors to provide a ground bus within cross section segments of a cable tray system. These ground bus extension conductors **shall** be of the same specification as the ground bus conductor and **shall** be routed with all connections to the ground bus conductor pointed in the direction of the MGB or SSGB. The ground bus extension conductor **shall** be bonded to the ground bus conductor using suitable methods described within this chapter.

Equipment grounding conductors from each cabinet, rack or individual system component chassis **shall** be bonded to the ground bus conductor or ground bus extension conductor using methods described within this chapter. See Figure 5-17. Ground bus conductors are not required to be installed at all locations, provided that equipment grounding conductors from each cabinet, rack and individual system component extend to the MGB or SSGB.

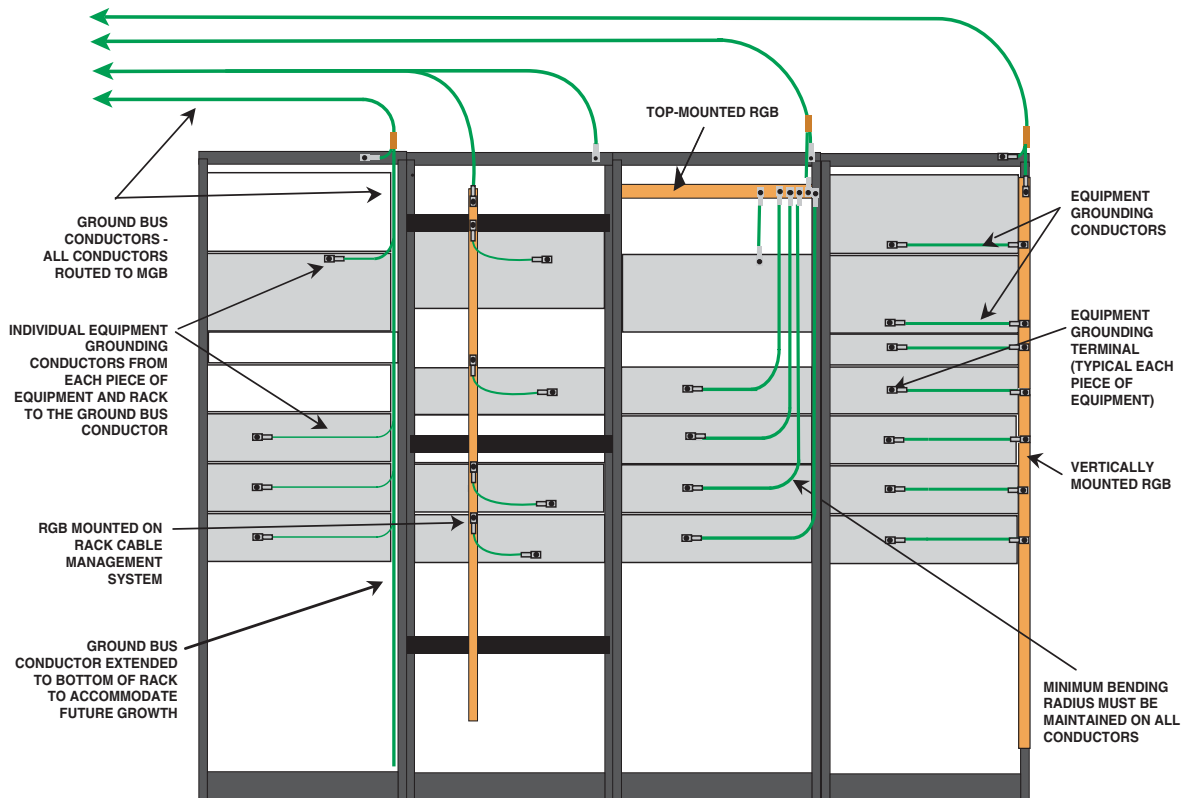

FIGURE 5-17 ACCEPTABLE METHODS FOR BONDING FROM THE EQUIPMENT TO THE MGB

5.3.5.1 LOCATION

One or more ground (earth) bus conductors **shall** typically be installed within the cable tray system above or below the equipment rows, as required by equipment layout and cable tray configuration. Typically one ground bus conductor is installed in each cable tray running the length of the equipment area. Each equipment row **shall** have a ground bus conductor installed in each cable tray cross section. This conductor may be a ground bus extension conductor from the main ground bus conductor. See Figure 5-16 on page 5-23. Minimum bending radius and angle **shall** be observed.

5.3.5.2 SPECIFICATIONS

Ground (earth) bus conductors, including ground bus extension conductors, **shall** be a 35 mm² csa (#2 AWG) or coarser, green-jacketed, solid or stranded copper conductor. When the conductors are insulated, they **shall** be listed for the space in which they are intended to be placed and the jacket **shall** be green or properly marked with a distinctive green color (ANSI-J-STD-607-A-2002).

The length of a 35 mm² csa (#2 AWG) ground bus conductor should not exceed 10 m (33 ft.). If a greater conductor length is required, the conductor should be sized at 2 kcmil per linear ft. of conductor length up to a maximum size of 95 mm² csa (#3/0 AWG). For conductor sizing requirements, see Table 5-3 and Table 5-4 on page 5-27 (ANSI-J-STD-607-A-2002 and MIL-HDBK-419A).

For specific applications a copper bus bar of equal or larger size may be used. An example of such an application is a bus bar mounted from bottom to top of an equipment rack or cabinet, with individual equipment ground connections suitably attached to the bar.

5.3.6 COMMUNICATION BONDING BACKBONE CONDUCTOR AND GROUNDING (EARTHING) EQUALIZER CONDUCTORS

A communication bonding backbone conductor is used to interconnect multiple equipment areas within small, large and multistory buildings. This type of conductor is similar to a ground (earth) bus conductor in that it is used to interconnect all main SSGBs on each floor or within each equipment room to the MGB. The intended function of the communication bonding backbone conductor is to reduce or equalize potential differences between all interconnected communication systems within the building.

When two or more communication bonding backbone conductors are used within a large or multistory building, the communication bonding backbone conductors are bonded together with grounding equalizer conductors as described within this chapter to equalize potential differences between the separate communication bonding backbone conductors and each equipment area's main SSGBs within the building.

5.3.6.1 LOCATION

The communication bonding backbone conductor originates at the building's main grounding (earthing) electrode bonding location and extends throughout the building within telecommunication cable pathways. The pathways **shall** be configured to maintain proper cable group separation from other cable groups and address routing to minimize the lengths of the communication bonding backbone conductor. The end of the conductor opposite the building's main grounding electrode bonding location typically remains unterminated, although this end of the conductor may be terminated directly to the furthest SSGB as described within this chapter.

Depending on the building construction, building size, communication system requirements, and the telecommunication cable pathways, one or more communication bonding backbone conductors may be installed. Each communication bonding backbone conductor **shall** be consistent with the design of the communication bonding backbone cabling system, and it **shall** be installed so that it is protected from physical damage.

Typically when the equipment rooms or areas are located on different floors of a large multi-story building, a separate communication bonding backbone conductor is routed up each of the opposite sides of the building. To equalize potential, the communication bonding backbone conductors are bonded together with a grounding equalizer conductor at the top floor and at a minimum of every third floor in between using methods described within this chapter (ANSI-J-STD-607-A-2002).

5.3.6.2 SPECIFICATIONS

All communication bonding backbone conductors and grounding (earthing) equalizer conductors **shall** be established of 35 mm² csa (#2 AWG) or coarser, solid or stranded copper conductor. When the conductors are jacketed, they **shall** be listed for the space in which they are intended to be placed and the jacket **shall** be green or properly marked with a distinctive green color (ANSI-J-STD-607-A-2002).

In the buildings that do not have effectively bonded structural steel, additional conductor sizing should be considered. All communication bonding backbone conductors and grounding equalizer conductors **shall** be of the same size. The linear length of a 35 mm² csa (#2 AWG) communication bonding backbone conductor or a grounding equalizer conductor should not exceed 10 m (33 ft.). If a greater conductor length is required, these conductors should be sized at 2 kcmil per linear foot of conductor length up to a maximum size of 95 mm² csa (#3/0 AWG). See Table 5-3 and Table 5-4 on page 5-27 for conductor sizing requirements (ANSI-J-STD-607-A-2002; MIL-HDBK-419A).

All communication bonding backbone conductors and grounding equalizer conductors should be installed without splices. When splices are necessary, the number of splices **shall** be kept to a minimum and the splices **shall** be accessible and located in telecommunication spaces (ANSI-J-STD-607-A-2002). All communication bonding backbone and grounding equalizer conductor splices **shall** be established using suitable methods described within the chapter.

NOTE: The interior water piping system of the building and metallic cable shields **shall not** be used as communication bonding backbone conductors or grounding equalizer conductors (ANSI-J-STD-607-A-2002).

Each equipment area's main SSGB **shall** be bonded to the communication bonding backbone conductor or to the grounding equalizer conductor with a grounding conductor of the same size as the communication bonding backbone conductor using suitable methods described within this chapter. The building's MGB **shall** be bonded to the service equipment (power) grounding electrode system using a grounding conductor of the same size as the communication bonding backbone conductor by using suitable methods described within this chapter (ANSI-J-STD-607-A-2002).

TABLE 5-3 SIZING OF GROUND BUS CONDUCTORS

Conductor length in linear m (ft)	Conductor size in mm ² csa (AWG / MCM)
Less than 10 (33)	33.62 (2)
10 – 13 (34 – 41)	42.41 (1)
13 – 16 (42 – 52)	53.49 (1/0)
16 – 20 (53 – 66)	67.43 (2/0)
20 – 25 (67 – 84)	85.01 (3/0) ¹
25 – 32 (85 – 105)	107.26 (4/0)
32 – 38 (106 – 125)	126.70 (250 MCM)
38 – 53 (126 – 175)	177.39 (350 MCM)
53 – 76 (176 – 250)	253.35 (500 MCM)
Greater than 114 (251 – 375)	380.13 (750 MCM)

1. Maximum wire size required by this standard. The remaining five wire sizes shown are recommendations for the given respective lengths.

TABLE 5-4 STANDARD WIRE SIZES AVAILABLE FOR INTERNATIONAL MARKET

Conductor size in mm ² csa	Conductor size in AWG / MCM
6	10
10	8
16	6
25	4
35	2
50	1/0
75	2/0
95	3/0
120	4/0
150	300 MCM
185	350 MCM
240	500 MCM
300	600 MCM
400	800 MCM

5.3.7 INTERNAL PERIMETER GROUND (EARTH) BUS CONDUCTORS

The internal perimeter ground (earth) bus (IPGB) provides a suitable grounding conductor to the MGB for ancillary support apparatus, electrical conduits and other metallic items that may be located throughout the shelter, building or room. It is essential that all ancillary metallic items within the area be bonded to the single point ground established by the MGB or SSGB.

An internal perimeter ground bus conductor should be installed in all equipment shelters, buildings or rooms specifically designed or designated for communications equipment, or a generator or power distribution room. Motorola recommends an IPGB whenever a tower is associated with the site. An internal perimeter ground bus conductor is not required in rooms or areas that are within a larger building where ancillary support apparatus (non-electronic equipment) is not present or where it is more practical to bond this support apparatus to the MGB or SSGB with individual equipment grounding conductors. An internal perimeter ground bus conductor may be installed in areas where there is a need to bond several items of support apparatus to the MGB or SSGB regardless to the specific usage of the area.



CAUTION

The internal perimeter ground bus conductor shall not be used for bonding communications equipment such as cabinets, racks, chassis or equipment grounding conductors to the MGB (ANSI T1.334-2002).

5.3.7.1 LOCATION AND INSTALLATION

When used, the internal perimeter ground (earth) bus **shall** be installed such that it encompasses the interior of the shelter, building, room or area with two independently separate ground bus conductors on opposite sides of the room. Each of these conductors **shall** be located horizontally along the wall, approximately 2.4 m (8 ft.) above the finished floor or within 305 mm (1 ft.) below the ceiling and terminated to the MGB or SSGB, as applicable, at one end only, using methods described within this chapter. The two bus conductors should meet at a point within the equipment area and approximately opposite the location of the MGB. At the location where the two bus conductors meet, the bus conductors **shall** be separated by a minimum distance of 104 mm (4 in.). See Figure 5-1 on page 5-4 for an example of this type of configuration.

The conductors **shall** be supported approximately 51 mm (2 in.) from the wall surface on insulated standoffs. Standoffs **shall** be installed at approximately 610 mm (2 ft.) intervals or as necessary to keep the conductor securely in place without noticeable sags and bends. Where transmission lines enter the equipment area at a lower point along the wall or through the floor or ceiling and the MGB is suitably located lower on the wall or on the floor or ceiling, the internal perimeter ground bus conductors **shall** be routed as stated above, with the following exception: at a point where these conductors can be readily connected to the MGB or SSGB, these conductors **shall** be routed across the ceiling or downward along the wall and connected to the MGB or SSGB; a vertical cable ladder of suitable design may be used for protection and support.

5.3.7.2 SPECIFICATIONS

The internal perimeter ground (earth) bus conductors **shall** be a 35 mm² csa (#2 AWG) or coarser copper conductor, free of splices. When the conductors are insulated, they **shall** be listed for the space in which they are intended to be placed and the jacket **shall** be green or properly marked with a distinctive green color (ANSI-J-STD-607-A-2002). If a splice in the bus conductor is unavoidable, it **shall** be exothermically welded or spliced using a listed irreversible connection. It is desirable that this conductor be stranded for better flexibility and ease of installation and maintenance. However, this conductor may be a solid conductor, copper bus bar, or copper strap of equal or larger surface area.

5.3.8 EQUIPMENT GROUNDING (EARTHING) CONDUCTORS

An equipment grounding (earthing) conductor bonds equipment chassis or frames, and metallic ancillary support apparatus to the internal grounding system. An equipment grounding conductor from each piece of electronic equipment **shall** be bonded to the MGB, SSGB, RGB, ground bus conductor or ground bus extension using suitable methods described within this chapter. An equipment grounding conductor from each piece of ancillary support apparatus **shall** be bonded to the MGB, SSGB or internal perimeter ground bus (IPGB) conductor using suitable methods described within this chapter.

NOTE: Braided conductors **shall not** be used at any location.

5.3.8.1 LOCATION

The equipment grounding (earthing) conductor for electronic equipment **shall** be suitably supported. One end of the conductor **shall** be bonded to the equipment or support apparatus using methods described within this chapter. The other end of the conductor **shall** be bonded to the ground bus conductor, RGB, SSGB, or MGB using suitable methods described within this chapter. See Figure 5-17 on page 5-24.

5.3.8.2 SPECIFICATIONS

The equipment grounding (earthing) conductor **shall** be a 16 mm² csa (#6 AWG) or larger, green-jacketed, solid or stranded copper conductor. A stranded conductor may be more desirable due to the ease of installation and maintainability. If the equipment grounding conductor length must exceed 4 m (13 ft.) before it terminates to a ground bus conductor, RGB, SSGB, or MGB, the conductor **shall** be sized according to Table 5-5.

TABLE 5-5 SIZING OF GROUND BUS CONDUCTORS

Conductor length in linear m (ft)	Conductor size in mm ² csa (AWG)	International Conductor size (mm ² csa)
Less than 4 (13)	13.30 (6)	16
4 – 6 (14 – 20)	21.15 (4)	25
6 – 8 (21 – 26)	26.67 (3)	30
8 – 10 (27 – 33)	33.62 (2)	35

5.3.9 BONDING JUMPERS

A bonding jumper is used to ensure an electrically conductive path between components. Examples include sections of a cable tray which are required to be bonded together, or sections of structural steel, roof trusses, piping systems, conduits or other metallic surfaces that are required to be bonded together to maintain electrical conductivity. A bonding jumper **shall not** be used in lieu of an equipment grounding (earthing) conductor.

5.3.9.1 LOCATION

Bonding jumpers **shall** be installed to bond components of the same or similar structure together. The location will be dependent on the specific application. Bonding jumpers **shall** be as short as possible, **shall** be routed in as straight a line as possible, and **shall** be as free from bends as is practicable. Care **shall** be taken to ensure that attachment points are clean and free of paint, corrosion or non-conductive materials. Suitable listed lugs **shall** be used to facilitate attachment to the components as described within this chapter. See Figure 5-18 for an example of for an example of a cable tray section bonding jumper.

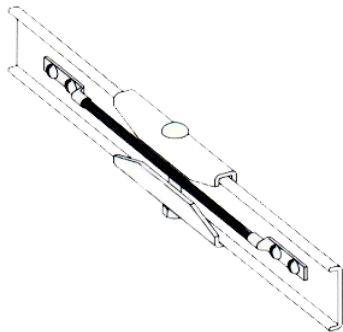

FIGURE 5-18 BONDING CABLE TRAY SECTIONS

5.3.9.2 SPECIFICATIONS

Bonding jumpers **shall** be 16 mm² csa (#6 AWG) or coarser, solid or stranded copper conductor. A stranded conductor may be more desirable due to the ease of installation and maintainability. When the conductors are insulated, they **shall** be listed for the space in which they are intended to be placed and the jacket **shall** be green or properly marked with a distinctive green color (ANSI-J-STD-607-A-2002 and NFPA 70-2005, Article 250.119). When bonding jumpers are installed outside a raceway or enclosure, their conductor length **shall not** exceed 1.8 m (6 ft.) (NFPA 70-2005, Article 250.102(E)).

5.4 CONNECTION METHODS FOR INTERNAL GROUNDING (EARTHING) SYSTEM

All components of the internal grounding (earthing) system and all equipment and ancillary support apparatus including, but not limited to, items listed in Table 5-6 on page 5-40 **shall** be effectively bonded together by using the following requirements and connection methods described within this chapter:

- General bonding requirements
- Bonding to equipment and ancillary support apparatus
- Bonding to the MGB
- Bonding to SSGB
- Bonding to RGB
- Bonding to ground bus conductor
- Bonding to communication bonding backbone conductors and grounding equalizer conductors

5.4.1 GENERAL BONDING REQUIREMENTS

The following requirements **shall** apply when attaching conductors to equipment, ancillary support apparatus, ground (earth) bus bars, and when attaching one conductor to another.

- Only connection devices that require the complete removal of the conductor jacket or insulation and result in a connection to the complete conductor surface area **shall** be suitable for use.
- All mechanical and compression-type connection devices **shall** be UL 486A listed and of the proper size for the application. These connection devices **shall** be tin-plated when connected with steel, galvanized steel or aluminum surfaces.
- All clamps and compression-type connection devices **shall** be UL 486A listed and **shall** maintain a minimum 88% conductivity rating.
- Compression systems **shall** include crimped die index and company logo for purposes of inspection.
- Listed two-hole, long barrel, compression lugs are preferred over single-hole lugs and **shall** be required where two-hole lugs are referenced within this chapter.
- No more than one clamp, fitting or lug may be attached by the same bolt or bolts. An exception to this is when a jumper from a terminal strip or other internal connection point of the same equipment must be bonded to the equipment grounding conductor.
- No more than one conductor **shall** be connected by a single clamp, fitting or lug unless the clamp, fitting, or lug is listed for multiple conductors.
- Solid conductors **shall** be attached to lugs and to other conductors by irreversible high compression crimping process. Only listed irreversible compression type lugs and connection devices **shall** be used.
- Connections between dissimilar metals **shall not** be made unless the conductors are separated by a suitable material that is a part of the attachment device. Only attachment devices listed and approved for use with the specific dissimilar metals may be used for this purpose.

- An appropriate type of listed, conductive anti-oxidant **shall** be applied on all connections of dissimilar metals. Copper enhanced anti-oxidant compound should be used between copper, brass, bronze and tin-plated bonding surfaces. Zinc enhanced anti-oxidant compound should be used between tin-plated connection devices and steel, galvanized steel, zinc-chromate steel, aluminum, and tin-plated copper bus bar bonding surfaces.
- Where threaded or tapped holes are provided for attachment purposes, a star or split type lock washer **shall** be installed under the head of the screw or bolt and/ or between the nut and the ground bus bar. See Figure 5-19 on page 5-32 for the correct location of the star or split washer in these instances.
- Self-tapping or sheet metal type screws **shall not** be used for attaching ground or grounding conductors to any surface. (See NFPA 70-2005, Article 250.8 for additional information.)
- Paint, enamel, lacquer, or other nonconductive coatings **shall** be removed from threads and surface areas where connections are made (NFPA 70-2005, Article 250.12). Use of a star washer **shall not** alleviate the requirement to remove nonconductive coatings from attachment surfaces. Star or split type washers **shall not** be installed between the conductive surfaces. Proper placement of lockwasher is shown in Figure 5-19.

NOTE: Do not install a washer of any kind between the ground lug and the bonding surface.

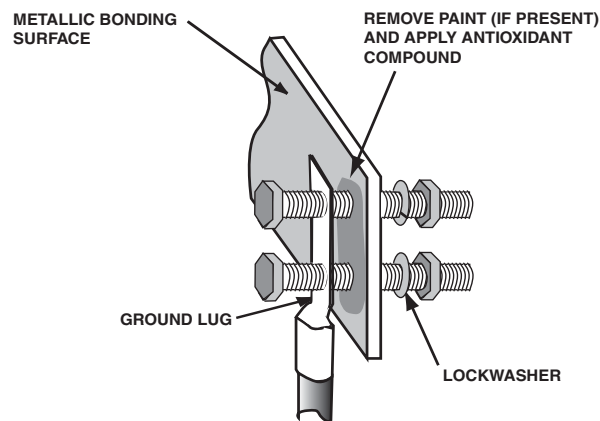

FIGURE 5-19 PROPER LOCATION OF WASHER WHEN CONNECTING GROUND LUG

- All two-hole lugs **shall** have bolts in both holes with lock washers placed on the nut side of the bonding surface.
- All securing hardware for mechanically bolted clamps and lugs **shall** be stainless steel or approved for the application.

The following methods of connection are **unacceptable** and **shall not** be used:

- Insulation piercing connectors.
- Self-tapping or sheet metal type screws **shall not** be used to provide continuous and permanent electrical bonds (NFPA 70-2005, Article 250.8 and FAA-STD-019d-2002).
- Tinnerman or similar type clips (FAA-STD-019d-2002).
- Aluminum connection devices.

- Star or split washers **shall not** be installed between conductive surfaces. These washers may be used only under the head and/or nut of the bolt as shown in Figure 5-19.
- The series or daisy chain method of connecting a conductor from one piece of equipment to another and then to the ground bus conductor **shall not** be permitted (FAA-STD-019d-2002). The series or daisy chain method refers to any method of connection whereby the conductors are connected from one chassis, equipment frame or rack connection point to a second chassis, equipment frame or rack connection point and on to a third connection point, creating a series arrangement whereby the removal of the second connection point interrupts the ground path from the first chassis, equipment frame or rack. See Figure 5-20 on page 5-34.
- When attaching two conductors together, or attaching a conductor to a lug, connections **shall not** depend solely on solder (NFPA 70-2005, Articles 250.8 and 250.70) although properly crimped connections may be soldered.
- Crimp connections **shall not** be used on solid conductors unless they are listed and approved for the application.
- Mechanical lugs and clamps (such as set screw lug or clamp) **shall not** be used on solid conductor.
- Conductors **shall not** extend through or beyond the clamp, fitting or lug unless the device is designed and listed to permit this conductor extension.
- Braided conductors **shall not** be used as a ground bus or equipment grounding conductor at any location (FAA-STD-019d-2002).

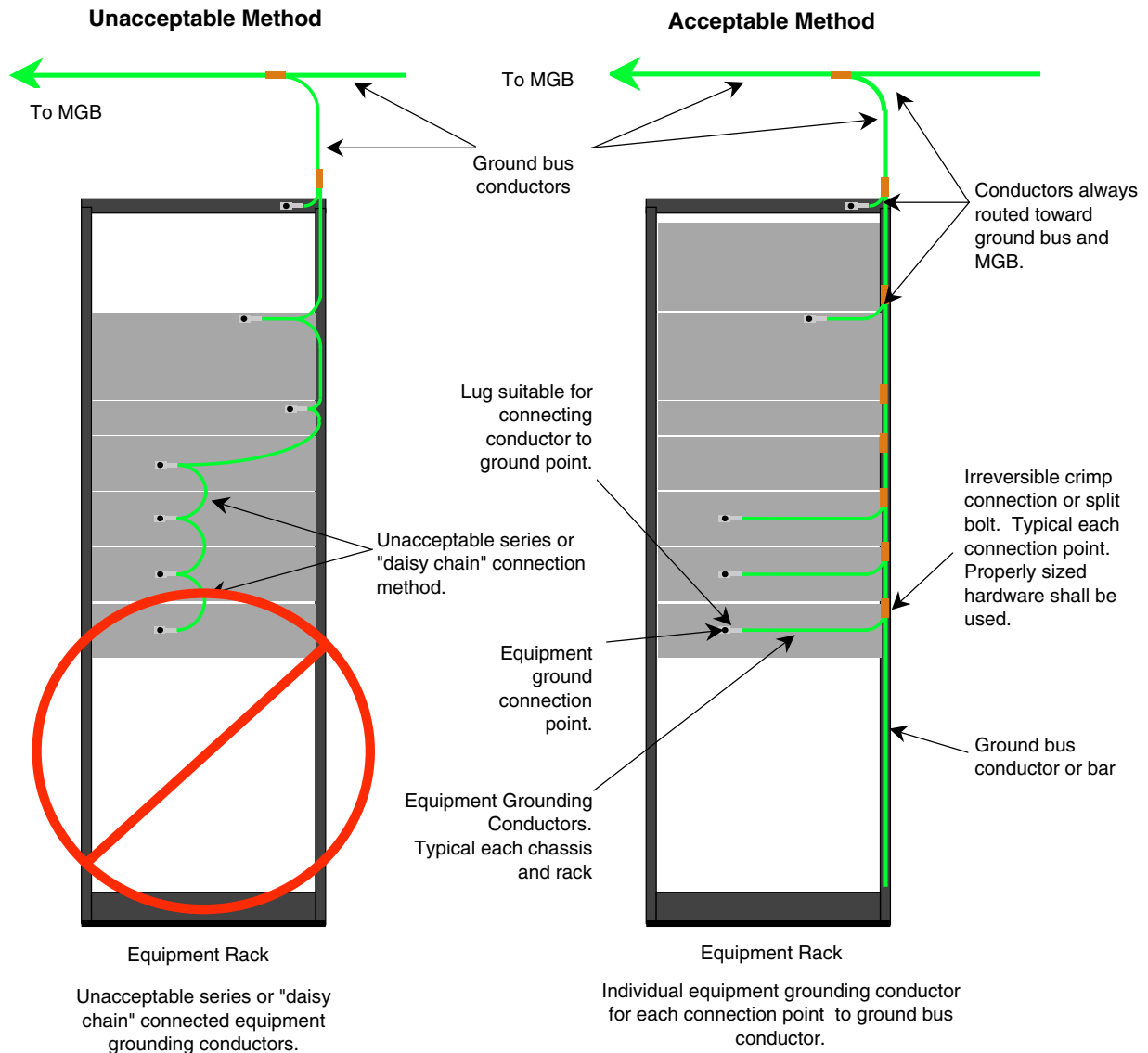

FIGURE 5-20 DAISY CHAIN GROUNDING NOT ALLOWED

5.4.2 BONDING TO EQUIPMENT AND ANCILLARY SUPPORT APPARATUS

All applicable general and below bonding requirements **shall** apply when attaching equipment grounding (earthing) conductors to equipment and ancillary support apparatus:

- Each electronic equipment chassis **shall** have a separate and independent equipment grounding conductor.
- Paint, enamel, lacquer and other electrically non-conductive coatings **shall** be completely removed from threads and bonding surface areas to ensure good electrical continuity (NFPA 70-2005, Article 250.12).

NOTE: Use of a star washer does not alleviate the requirement to remove non-conductive coatings from attachment surfaces because the star washer does not provide enough contact surface area.

- Connections to steel and galvanized steel pipes, conduit or other round member items **shall** be made using a UL 486A listed, bolted clamp with stainless steel securing hardware or other suitable listed means. In high humidity areas, the clamps **shall** be stainless steel or tin-plated UL 486A listed to prevent galvanic corrosion.
- Connections to vibrating or moveable items **shall** be made by using an exothermic weld or a compression-type two-hole lug.
- Connections to structural building steel **shall** be made by using an exothermic weld, listed irreversible high compression-type connection, or listed tin-plated flange-type bonding connector that is equipped with two securing bolts. Figure 5-21 shows examples of flange-type bonding connectors.

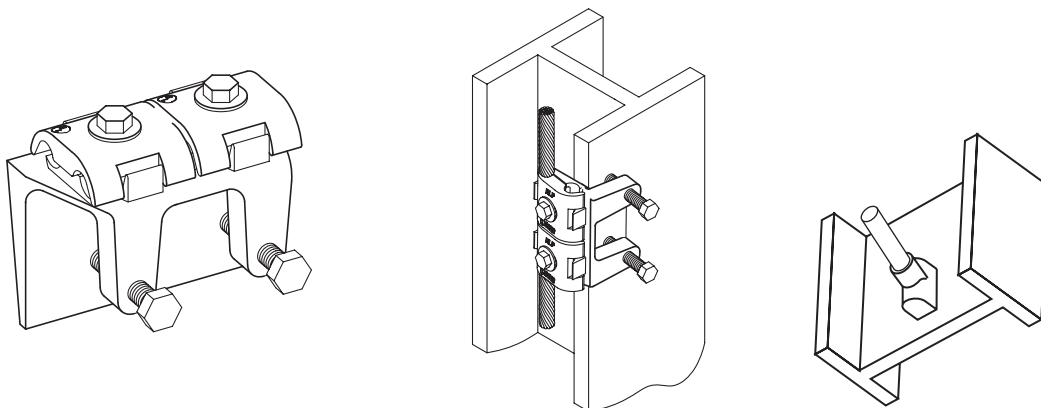

FIGURE 5-21 ACCEPTABLE BUILDING STEEL BONDING CONNECTIONS

- Connections to raised flooring support system **shall** be made using a tin-plated listed compression lug, listed pedestal clamp, or exothermic welding. Where practical the lug should be effectively bonded to the pedestal's upper support plate or to cross connecting stringer. Figure 5-22 shows some examples of acceptable pedestal bonding configurations.

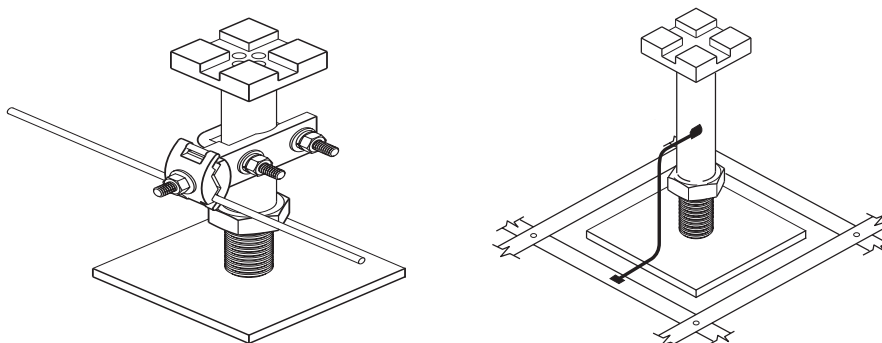

FIGURE 5-22 ACCEPTABLE RAISED FLOORING BONDING CONNECTIONS

5.4.3 BONDING TO THE MGB, SSGB AND RGB

All applicable general bonding requirements and the bonding requirements listed below **shall** apply when attaching grounding (earthing) conductors, grounding electrode conductors, ground bus conductors and equipment grounding conductors to the MGB, SSGB or RGB:

- The MGB grounding conductor(s) **shall** be installed using the shortest and straightest downward-flowing path toward the earth and the grounding electrode system. For examples of grounding conductor routing requirements see Figure 5-8 on page 5-12 and Figure 5-9 on page 5-14.
- All ground bus conductors and equipment grounding conductors bonded directly to the MGB, SSGB or RGB **shall** have a direct path back toward the grounding electrode system.
- Connection of a grounding conductor, grounding electrode conductor, communication bonding backbone conductor and ground bus conductor to the MGB or SSGB **shall** utilize exothermic welding, listed irreversible compression-type connection or listed compression two-hole lug and securing hardware of the proper size for the application unless otherwise specified within this chapter (ANSI-J-STD-607-A-2002).
- Connection of a grounding conductor, grounding electrode conductor and ground bus conductor to the RGB **shall** utilize exothermic welding, listed irreversible compression-type connection, or listed compression lug and securing hardware of the proper size for the application. Listed compression two-hole lugs are preferred.
- Connection of an equipment grounding conductor to the MGB, SSGB or RGB **shall** utilize exothermic welding, listed irreversible compression-type connection, listed compression lug, or listed pressure lug and securing hardware of the proper size for the application. Listed compression two-hole lugs are preferred (ANSI-J-STD-607-A-2002).
- Grounding materials should be of copper or copper alloy. Where other materials are used in conjunction with copper or copper alloy, care **shall** be exercised in providing proper bimetallic couplings to reduce the possibility of galvanic corrosion (ANSI T1.334-2002; ANSI T1.313-2003).
- It is desirable for the MGB, SSGB, and RGB to be electrotin-plated for reduced contact resistance. If not electrotin-plated, the bus bar bonding surface **shall** be cleaned prior to fastening the conductor's connection device. An appropriate type of listed conductive anti-oxidant compound should be applied to the contact area to control corrosion and reduce contact resistance of mechanical and compression-type connections.

Some customers such as cellular operators may require that conductors be bonded to the MGB in a specific sequence or order determined by the conductor's origin or the type of equipment being bonded to the MGB. One of these methods, known as PANI, allocates specific areas of the MGB for bonding surge energy **P**roducers, **A**bsorbers, **N**on-isolated equipment, and **I**solated equipment. An example of this type of configuration is shown in Figure 5-23 and Figure 5-24. This method is not required for compliance with this installation standard and is provided for reference only. See ANSI T1.313-2003 for additional information on this method of bonding to the MGB.

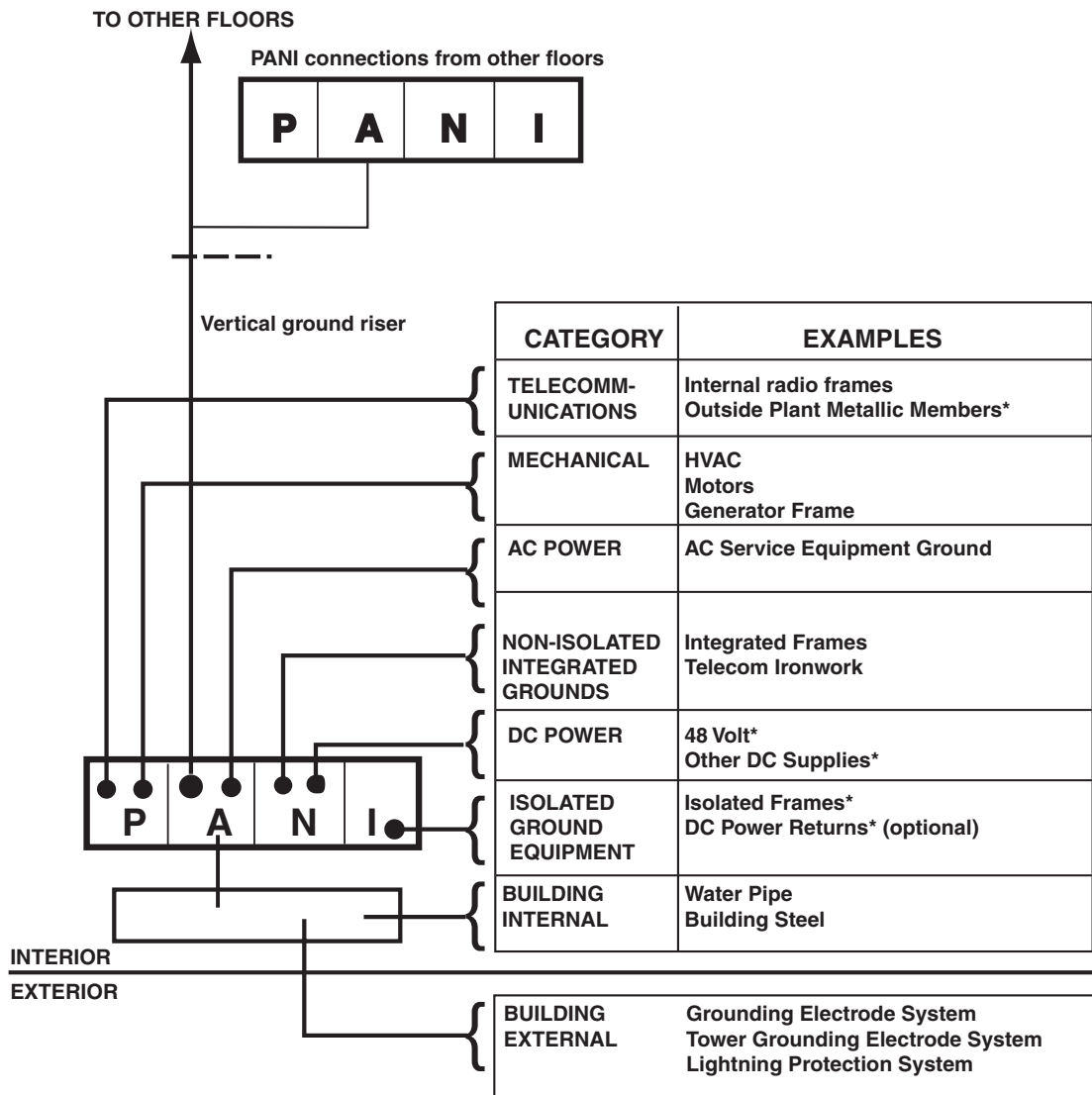

NOTE:
Items marked with an asterisk (*) may have ground bars associated with them.

FIGURE 5-23 PANI GROUNDING SYSTEM SEQUENCE

P	A	N	I
Surge Producers	Surge Absorbers	Non IGZ	Isolated Ground Zones (IGZ)
<ul style="list-style-type: none"> • RF SPD • AC Equip. • Tel. SPD • Cable Shields • ESD 	<ul style="list-style-type: none"> • Building Steel • AC NG Bond • Water Line • Metallic Piping • Concrete Encased Electrode • Ground Rings 	<ul style="list-style-type: none"> • +48VDC GND. • -24VDC GND. • Cable Tray Sys. • Equip. Frame • Battery Racks • Ancillary Equip. 	<ul style="list-style-type: none"> • Logic Ground. • IG Zones

FIGURE 5-24 PANI BUS BAR CONFIGURATION

5.4.4 BONDING TO GROUND (EARTH) BUS CONDUCTORS

All applicable general bonding requirements **shall** apply when attaching ground (earth) bus extension conductors and equipment grounding conductors to a ground bus conductor. The following requirements also apply:

- All ground bus conductors should be installed without splices. Where splices are necessary, the number of splices should be kept to a minimum and they **shall** be accessible and only located in telecommunication spaces. The joined segments **shall** be connected using exothermic welding or listed irreversible compression-type connectors. All bonding joints **shall** be adequately supported and protected from damage (ANSI-J-STD-607-A-2002).
- Ground bus extension conductors **shall** always be routed toward the MGB or SSGB at the point of connection to the ground bus conductor. Ground bus extension conductors **shall** be connected to the ground bus conductor using exothermic welding or listed irreversible compression-type connectors. Connection points **shall** be taped with a suitable green tape or otherwise isolated from contact with the cable tray or other metallic surfaces.
- Equipment grounding conductors **shall** always be routed toward the MGB or SSGB at the point of connection to the ground bus conductor. Equipment grounding conductors **shall** be connected to the ground bus conductor using exothermic welding, listed compression-type connections, or listed split bolt connections. Connection points **shall** be taped with a suitable green tape or otherwise isolated from contact with the cable tray or other metallic surfaces.
- Equipment grounding conductors **shall** be connected so that the removal of a connection will not break the ground path to any other piece of equipment or ancillary support device that may have electrical power applied.
- Multiple connections **shall not** be made to one attachment point on the ground bus conductor unless this connection is made using exothermic welding, listed irreversible compression-type connector or listed split bolt. In all cases the connection means **shall** be listed for the size and number of conductors to be connected.

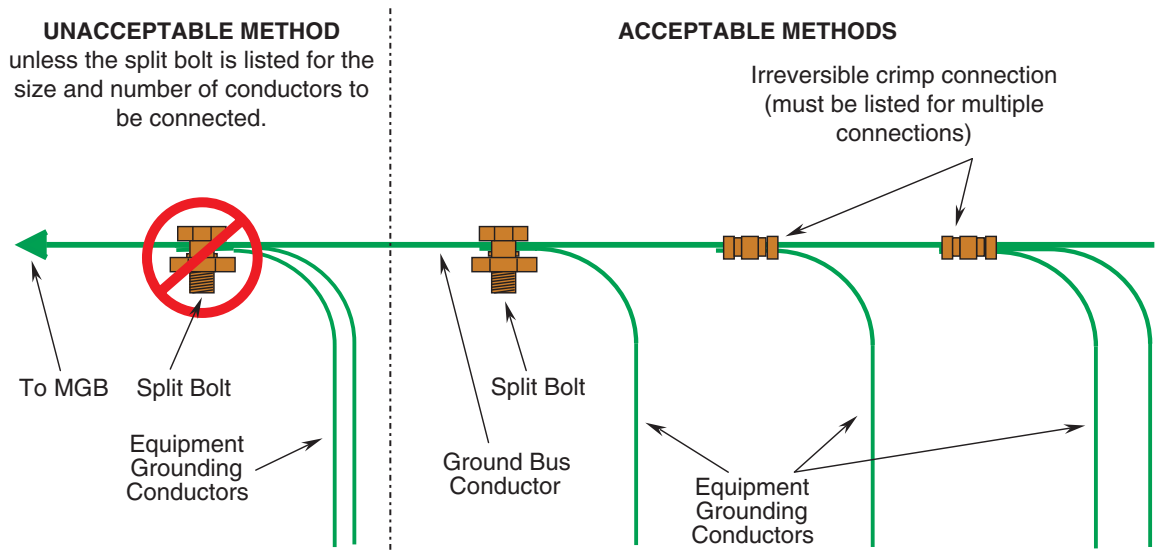

NOTE: Route all conductors toward the MGB.

FIGURE 5-25 BONDING TO GROUND BUS CONDUCTOR

5.4.5 BONDING TO COMMUNICATION BONDING BACKBONE CONDUCTORS AND GROUNDING (EARTHING) EQUALIZER CONDUCTORS

All applicable general bonding requirements and the requirements below **shall** apply when attaching SSGB grounding (earthing) conductors to a communication bonding backbone conductor or a grounding equalizer conductor.

NOTE: Only SSGBs should be bonded back to a communication bonding backbone conductor or a grounding equalizer conductor. All equipment and ancillary apparatus grounding conductors should be bonded back to the SSGB as described within this chapter.

- All communication bonding backbone conductors should be installed without splices. Where splices are necessary, the number of splices should be kept to a minimum and they **shall** be accessible and only located in telecommunication spaces. The joined segments **shall** be connected using exothermic welding or listed irreversible compression-type connectors. All bonding joints **shall** be adequately supported and protected from damage (ANSI-J-STD-607-A-2002).
- The bonding conductor between the SSGB and the communication bonding backbone or grounding equalizer conductor **shall** be of the same specifications as the communication bonding backbone conductor.
- The bonding conductor between the SSGB and the communication bonding backbone or grounding equalizer conductor **shall** be continuous and routed in the shortest possible straight line path back towards the MGB. If a bend is required in the SSGB bonding conductor, minimum bending radius and angle **shall** be adhered to.

- The SSGB bonding conductor **shall** be connected to the communication bonding backbone conductor or to the grounding equalizer conductor with an exothermic welding or listed irreversible compression-type connection (ANSI-J-STD-607-A-2002)
- When a grounding equalizer conductor is installed as described within this chapter, it **shall** be bonded back to the SSGBs and not to the communication bonding backbone conductors.
- The grounding equalizer conductor **shall** be connected to the SSGBs with exothermic welding, listed compression-type two-hole lugs, or listed irreversible compression type connections.
- Only the far end of a communication bonding backbone conductor may be connected directly to the SSGB. If the communication bonding conductor is connected directly to the SSGB, it **shall** be connected with exothermic welding or irreversible compression type connection. See Figure 5-4 on page 5-7 for an example of this type of grounding system configuration.

5.5 BONDING EQUIPMENT TO INTERNAL GROUNDING (EARTHING) SYSTEM

All equipment and ancillary support apparatus **shall** be bonded to the MGB, SSGB, RGB, ground (earth) bus conductor or internal perimeter ground bus (IPGB) conductor with an equipment grounding conductor as described within this chapter.

TABLE 5-6 BONDING TO THE INTERNAL GROUNDING SYSTEM FROM ITEM TOWARD EARTH

From Item	To					Minimum Conductor Size Unless Otherwise Specified	
	MGB	SSGB	RGB	Ground Bus Conductor	IPGB	35 mm ² csa (#2 AWG)	16 mm ² csa (#6 AWG)
SSGB	✓	✓		✓		✓	
RGB	✓	✓	✓	✓		✓	
Equipment ground bus extension	✓	✓	✓	✓		✓	
Equipment cabinet	✓	✓	✓	✓			✓
Equipment rack	✓	✓	✓	✓			
Equipment grounding conductor	✓	✓	✓	✓			✓
Individual system component chassis	✓	✓	✓	✓			✓
Control or Dispatch Centers electronic equipment and metallic parts of furniture	✓	✓	✓	✓			✓

TABLE 5-6 BONDING TO THE INTERNAL GROUNDING SYSTEM FROM ITEM TOWARD EARTH (CONTINUED)

From	To					Minimum Conductor Size Unless Otherwise Specified	
	MGB	SSGB	RGB	Ground Bus Conductor	IPGB	35 mm ² csa (#2 AWG)	16 mm ² csa (#6 AWG)
Cable tray	✓	✓					✓
Transmission line surge suppressors	✓	✓	✓	✓			✓
Primary surge suppressor	✓	✓		✓			✓
Secondary surge suppressor	✓	✓	✓	✓			✓
DC power plant	✓	✓				✓	
Separately derived AC electrical systems	✓	✓		✓		✓	
IPGB	✓	✓				✓	
Ancillary support items and metallic structural items	✓	✓			✓		✓

5.5.1 EQUIPMENT AND ANCILLARY SUPPORT APPARATUS BONDING

All equipment and ancillary support apparatus including, but not limited, to that listed below **shall** be effectively bonded back to the internal grounding system with a minimum 16 mm² csa (#6 AWG) equipment grounding conductor unless otherwise specified herein. All grounding and bonding conductors **shall** be established by using the following requirements and connection methods described within this chapter:

- Separately Derived AC Systems
- DC Power Plant
- Equipment
- Cabinets and Racks
- Cable Trays
- Ancillary Support Apparatus
- Metallic Building Structure and Piping Systems
- Surge Protection Devices

5.5.1.1 SEPARATELY DERIVED AC SYSTEMS

Separately derived AC electrical power systems have no direct electrical connection between the incoming neutral from the AC power source and the neutral conductor on the secondary side of the separately derived AC power system. Separately derived power systems can include isolation transformers, step-down or step-up transformers, generator AC power systems that are breaking the neutral conductor inside the auto transfer switch (ATS), Uninterruptible Power Supply (UPS) systems that are configured as separately derived systems, or AC inverters that are powered by a battery bank.

If a separately derived AC power system exists at the site within the communication system equipment area, a grounding conductor for the neutral to ground bond on the secondary side of the unit **shall** be bonded back to the equipment area's single point grounding system (MGB or SSGB, where the MGB is not co-located) with a 35 mm² csa (#2 AWG) or coarser, green-jacketed grounding conductor. Where applicable, the grounding conductor should be up-sized to meet NFPA 70-2005, Article 250.66 requirements. The grounding conductor **shall** be bonded to both locations with compression-type, two-hole, UL 486A listed lugs as described within this chapter.

If a separately derived AC power system exists at the site but not located at the communication system equipment area, a grounding conductor for the neutral to ground bond on the secondary side of the unit **shall** be referenced back to the common building grounding electrode system with no less than a 35 mm² csa (#2 AWG) or coarser, copper grounding conductor.

NOTE: Generators are often shipped from the manufacturer with a neutral to ground bond established within the generator unit. If the generator's ATS panel is not configured as a separately derived system, this bonding conductor must be removed.

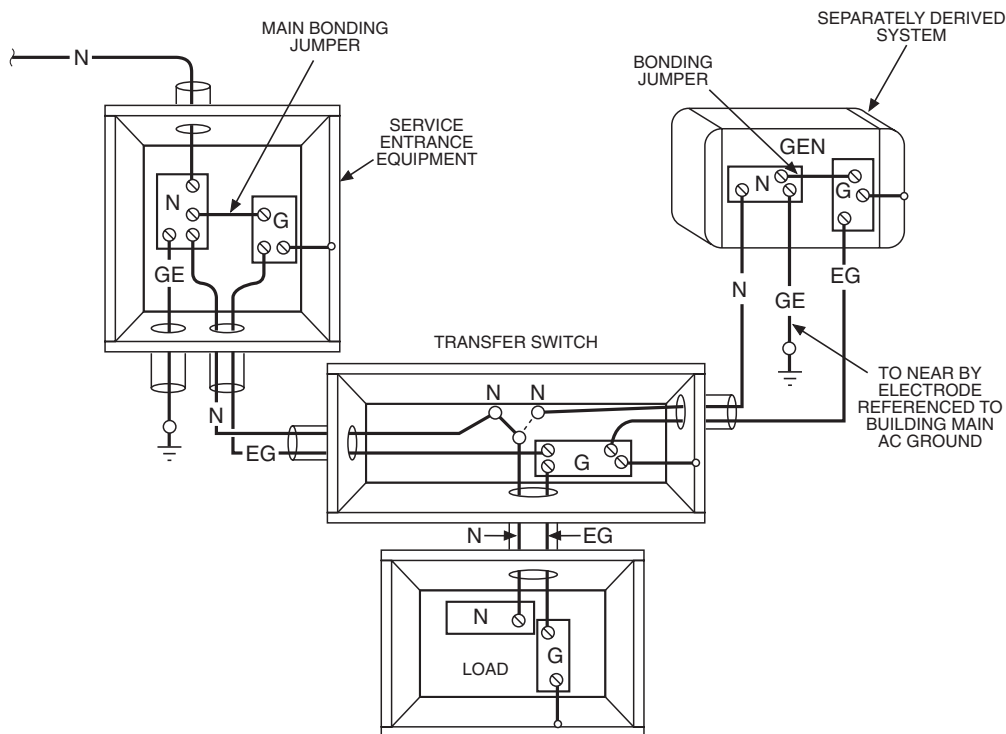

FIGURE 5-26 GENERATOR SYSTEM WITH SWITCHED NEUTRAL

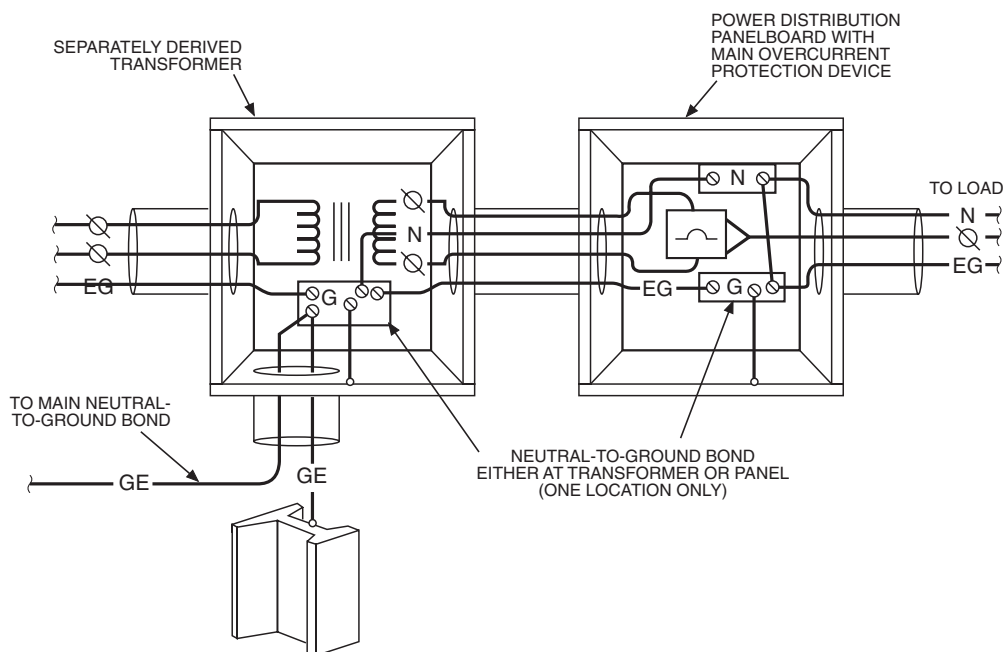

FIGURE 5-27 GROUNDING OF A DRY TYPE ISOLATION TRANSFORMER

5.5.1.2 DC POWER PLANT

The main DC power plant return bus **shall** be bonded to the facility single point grounding (earthing) system through a connection to the equipment room's single point ground. This single point ground should be the MGB, unless the MGB is located elsewhere in the building. In this case the grounding conductor can be effectively bonded to a properly installed SSGB. The DC power plant return bus **shall** be bonded to the single point ground with a grounding conductor no smaller than the largest conductor supplied by the DC power system, or no smaller than the grounding conductor for the SSGB and the grounding electrode conductor for the MGB. The DC power plant ground conductor **shall** be bonded to both bus bars with a compression-type two-hole UL 486A listed lug as described within this chapter. See Figure 5-28 for an example of this type of bonding configuration along with the required bonding of the power plant rack and battery rack frames (NFPA 70-2005, Articles 250.162, 250.164, and 250.166).

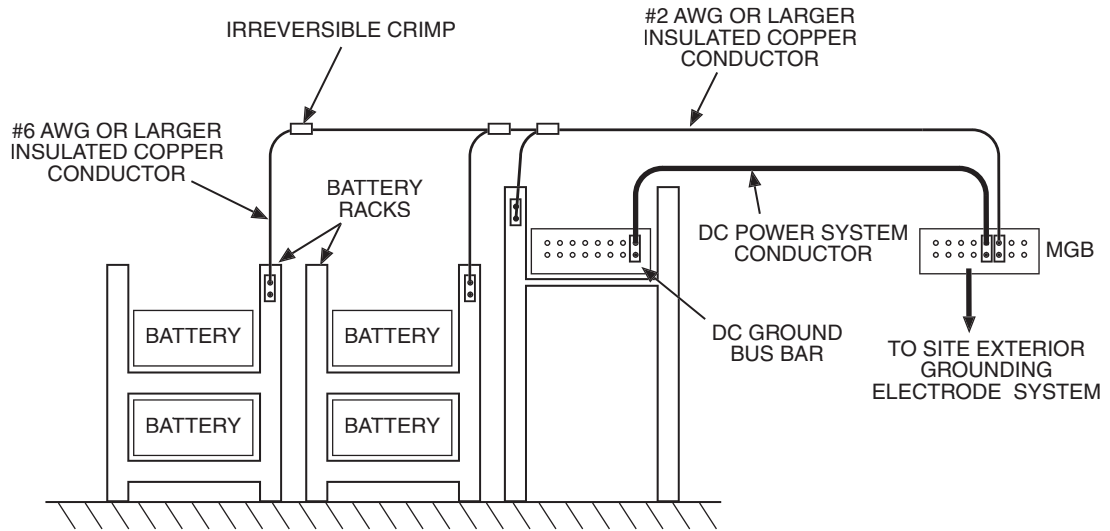

FIGURE 5-28 DC POWER PLANT AND FRAME GROUNDING

5.5.1.3 EQUIPMENT

The equipment grounding (earthing) conductor **shall** be attached to the equipment grounding terminal, chassis or frame utilizing methods described within this chapter. On equipment where a ground stud or connection point is provided by the manufacturer and this ground stud or connection point is sized and/or located so that a 16 mm² csa (#6 AWG) conductor cannot be reasonably attached, the 16 mm² csa (#6 AWG) equipment grounding conductor **shall** be attached to the equipment mounting screw or other suitable attachment point.

Where a terminal strip or other type connection point is an integral part of the equipment (PC board terminal, etc.) and this connection point must be connected to ground, a jumper sized per the manufacturer's instructions **shall** be installed between this point and the equipment grounding conductor. Manufacturer's installation instructions regarding grounding and bonding **shall** be followed in all instances unless the manufacturer specifies a grounding conductor smaller than 16 mm² csa (#6 AWG); in these cases a 16 mm² csa (#6 AWG) equipment grounding conductor **shall** be used. If the manufacturer has not provided specific grounding and bonding instructions for their equipment, the instructions contained within this paragraph **shall** prevail.

5.5.1.4 CABINETS AND RACKS

Conductor connections to racks and cabinets **shall** be made at the designated ground (earth) connection point or ground "pad." Connection to racks and cabinets without a designated connection point or ground pad **shall** be suitably made to the equipment mounting rail using bonding methods described within this chapter.

Racks or cabinets equipped with a RGB **shall** have an independent bonding jumper installed between the rack or cabinet grounding connection point and the RGB. Where its not practical to install a rack bonding jumper back to the RGB, the rack bonding jumper may be installed between the rack grounding connection point and the 35 mm² csa (#2 AWG) ground bus conductor or ground bus extension conductor using bonding methods described within this chapter. A stranded conductor may be more desirable due to the ease of installation and maintainability. All equipment within the rack or cabinet **shall** be bonded to the RGB with an equipment grounding conductor using bonding methods described within this chapter.

All metal non-current-carrying parts of the rack frame or cabinet enclosure that are to serve as grounding conductors, with or without the use of supplementary equipment grounding conductors, **shall** be effectively bonded where necessary to ensure electrical continuity and capacity to conduct any fault current likely to be imposed on them. To achieve effective bonding of the metal non-current-carrying parts, any non-conductive paint, enamel, or similar coating **shall** be removed at threads, contact points, and contact surfaces, or bonding must be connected using fittings designed to make such removal unnecessary (NFPA 70-2005, Article 250.96). If a bonding conductor is required, it **shall** be sized no smaller than 16 mm² csa (#6 AWG) and it **shall** be attached using bonding methods described within this chapter.

5.5.1.5 CABLE TRAYS

Bonding jumpers **shall** be installed at all cable tray splices and connection points unless the cable tray has labeling that identifies it as suitable for use as a grounding (earthing) conductor and it meets the requirements of NFPA 70-2005, Article 392.7(B). These type cable trays have bolted splices and the connection points use splined shoulder bolts which bite into the side rail of the cable tray to ensure a positive bond between sections. All bolts must be properly installed at each splice in the cable tray system per the manufacturer's instructions. Care must be taken to ensure a continuous electrical path. Bonding jumpers must be used where discontinuities such as expansion splice plates and hinged splice plates exist.

NOTE: Cable trays **shall not** be utilized as a ground bus conductor for equipment or ancillary support apparatus.

Bonding jumpers **shall** be installed on all metallic non-current-carrying portions of the cable tray system. A bonding jumper **shall** be installed between each cable tray section and between each piece of metallic non-current-carry support hardware to establish a effective current flow path back to the MGB. All bonding jumpers **shall** be as short and straight as possible. Where a bend is required in the bonding jumper, it **shall** adhere to the 203 mm (8 in.) minimum bending radius requirement. Cable trays with painted finishes or aluminum anodized finishes **shall** have the protective coating completely removed down to the bare metal at each bonding connection point, and the bonding connection point **shall** be treated with the appropriate type of conductive anti-oxidant compound before the bonding connection is established. See Figure 5-16 on page 5-23 for an example of this type of bonding configuration.

A cable tray system **shall** be effectively bonded back to the MGB with a grounding conductor no smaller than 16 mm² csa (#6 AWG). If the MGB is not located within the equipment room or area, the cable tray system **shall** be effectively bonded to the main SSGB within that room or area using bonding methods described herein. The grounding conductor connections between the cable tray and the MGB or SSGB **shall** be made using bonding methods described within this chapter.

When a cable tray system has been installed with a single section routing perpendicular to the MGB or SSGB, the cable tray section nearest to the bus bar **shall** have an equipment grounding conductor installed between one of the cable tray side rails and the MGB or SSGB. The grounding conductor **shall** be installed with the shortest and straightest routing possible. See Figure 5-29 for an example of this type of configuration.

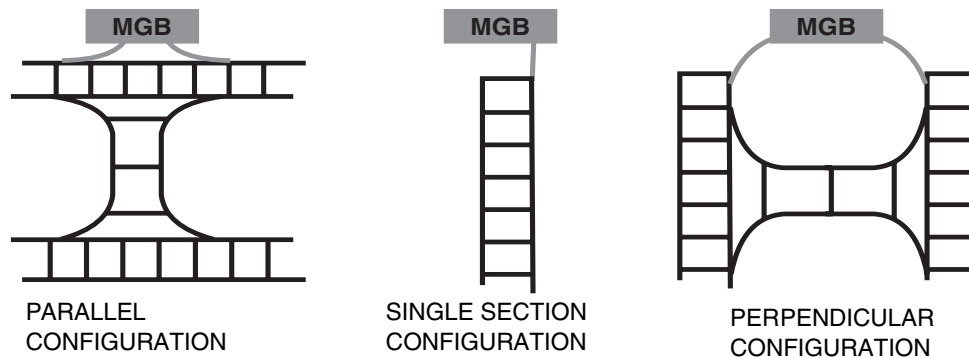

FIGURE 5-29 CABLE TRAY GROUNDING CONFIGURATIONS

When a cable tray system has been installed with a “U” shape section routing perpendicular to the MGB or SSGB, each cable tray section nearest to the bus bar **shall** have an equipment grounding conductor installed between the cable tray side rail and the MGB or SSGB. Each grounding conductor **shall** be installed with the shortest and straightest routing possible. See Figure 5-29 for an example of this type of configuration.

When a cable tray has been installed parallel to the MGB or SSGB, the cable tray section nearest to the bus bar **shall** have two equipment grounding conductors installed to provide a bidirectional flow path back to the MGB or SSGB. Each grounding conductor **shall** be installed with the shortest and straightest routing possible. See Figure 5-29 for an example of this type of configuration.

5.5.1.6 ANCILLARY SUPPORT APPARATUS

All ancillary support apparatus within an equipment shelter, room or specific equipment area **shall** be bonded to the MGB. In areas other than where the MGB is installed, ancillary support apparatus **shall** be bonded to the SSGB, or to the internal perimeter ground (earth) bus conductor (IPGB), using an equipment grounding conductor and methods described within this chapter.

Manufacturers' installation instructions **shall** be followed when bonding ancillary support apparatus to the site grounding system. Connections **shall** be made to the terminal provided or some other suitable point on the apparatus.

Ancillary support apparatus includes but is not limited to:

- Storage cabinets
- Battery racks
- Metallic window frames, doors and door frames
- Metallic ceiling grids

- Metallic raised flooring systems
- HVAC grills, ducts, units, motors, motor controllers, control panels, junction and terminal boxes
- Panelboards
- Switchboards
- Automatic and manual transfer switches
- Transformers
- UPS units
- Metallic housing of AC power surge suppressor devices
- Primary surge suppressor ground terminals

The following **shall** also be bonded to the MGB, SSGB or IPGB system:

- All metallic support apparatus, including metallic conduits, within an equipment shelter, room, a generator or power distribution room, or specific equipment area and located within 2.4 m (8 ft.) vertically or 1.5 m (5 ft.) horizontally of ground or grounded metal objects (NFPA 70-2005, Article 250 (VI)).
- Rigid Metallic Conduit (RMC) and Electrical Metallic Tubing (EMT). **EXCEPTION:** when the conduits are effectively joined with threaded coupling, threadless coupling, or threadless compression connector, that terminate in bonded metallic enclosures, they may be considered adequately bonded and do not require additional bonding (ANSI T1.334-2002).
- If metallic conduit does not meet the above specifications, the electrical metallic conduits **shall** be bonded to the IPGB conductor at any point where they cross within 152 mm (6 in.) of the IPGB conductor.
- Metallic conduit run parallel to the IPGB conductor **shall** be bonded at the points where it enters to within 152 mm (6 in.) of the IPGB conductor and at the point where it transitions away from the IPGB conductor.
- All set-screw type connectors and couplings **shall** be bridged with a bonding jumper.
- Each metallic conduit may be connected to the IPGB conductor with a continuous equipment grounding conductor using removable saddle clamps or other clamps that specifically permit the use of a single continuous conductor for grounding multiple runs of conduit. If multiple conduits are grounded using a single conductor, the conductor **shall** be clamped to each conduit run such that removal of one clamp does not interrupt the path to ground for the other conduit runs. See Figure 5-30 on page 5-48.

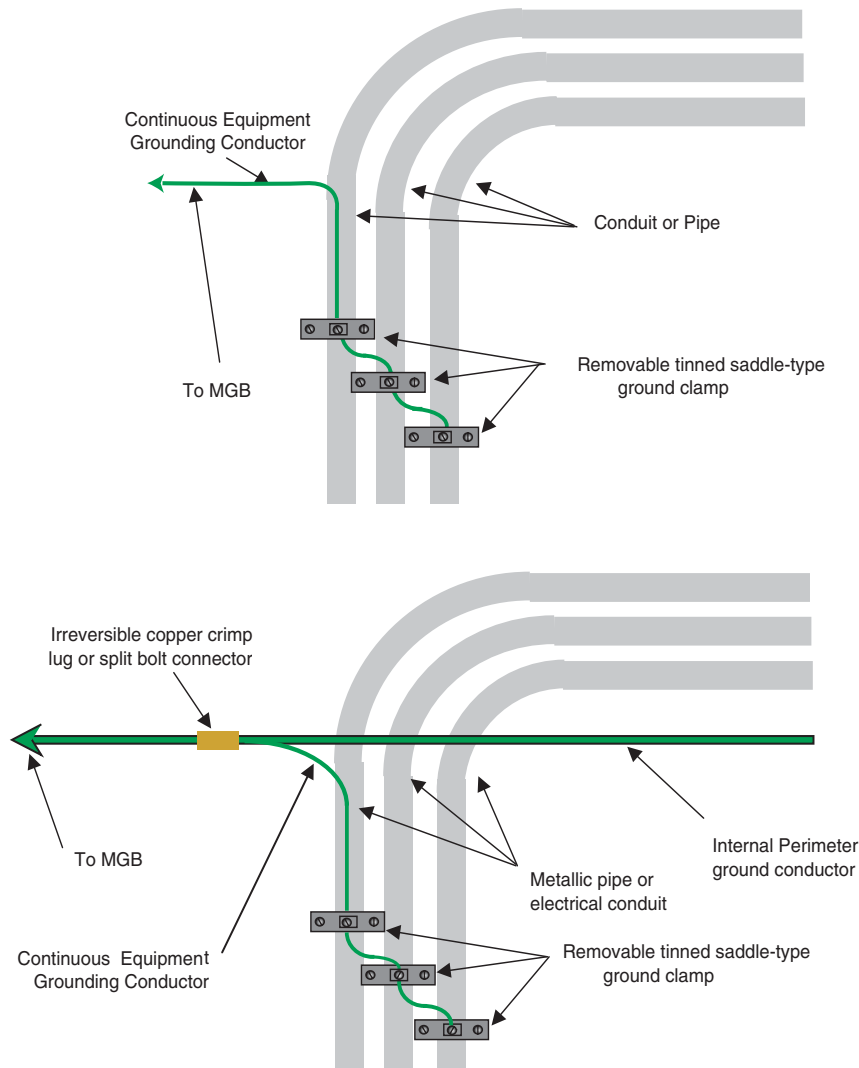

FIGURE 5-30 GROUNDING METHOD FOR METALLIC PIPE OR CONDUIT

5.5.1.7 METALLIC BUILDING STRUCTURE AND PIPING SYSTEMS

Metallic building structures and piping systems, steel roof trusses, exposed support beams and columns, drop ceiling grids, raised floor support structure, any metallic exposed building support structure and building frame when located within 2.4 m (8 ft.) vertically or 1.5 m (5 ft.) horizontally of the communications equipment, **shall** be bonded to the MGB, SSGB, or internal perimeter ground (earth) bus using one of the conductors and methods described within this chapter.

See Figure 5-21 on page 5-35.

No series or daisy chain connection arrangements **shall** be used. Each peripheral device **shall** be bonded to the MGB, SSGB, or perimeter ground bus using an individual equipment grounding conductor.

5.5.1.8 SURGE PROTECTION DEVICES (SPDs)

All surge protection devices and outside telecommunication cable metallic shields including, but not limited to, items listed below **shall** be effectively bonded back to the internal grounding (earthing) system with a 16 mm² csa (#6 AWG) or coarser equipment grounding conductor by using the following requirements and connection methods described within this chapter:

- Individual RF Surge Protection Devices
- Primary Surge Protection Devices
- Secondary Surge Protection Devices
- Telecommunication Cable Metallic Shields

5.5.1.8.1 RF SURGE PROTECTION DEVICES

RF transmission SPDs **shall** be bonded to the MGB within 610 mm (24 in.) of entry into the equipment shelter, equipment room or equipment area. A separate equipment grounding (earthing) conductor **shall** be used to bond each of these devices to the MGB or to a SSGb. RF transmission line SPDs may also be bonded directly to a SSGb, MGB, or the copper integrated entry panel with the proper securing hardware.

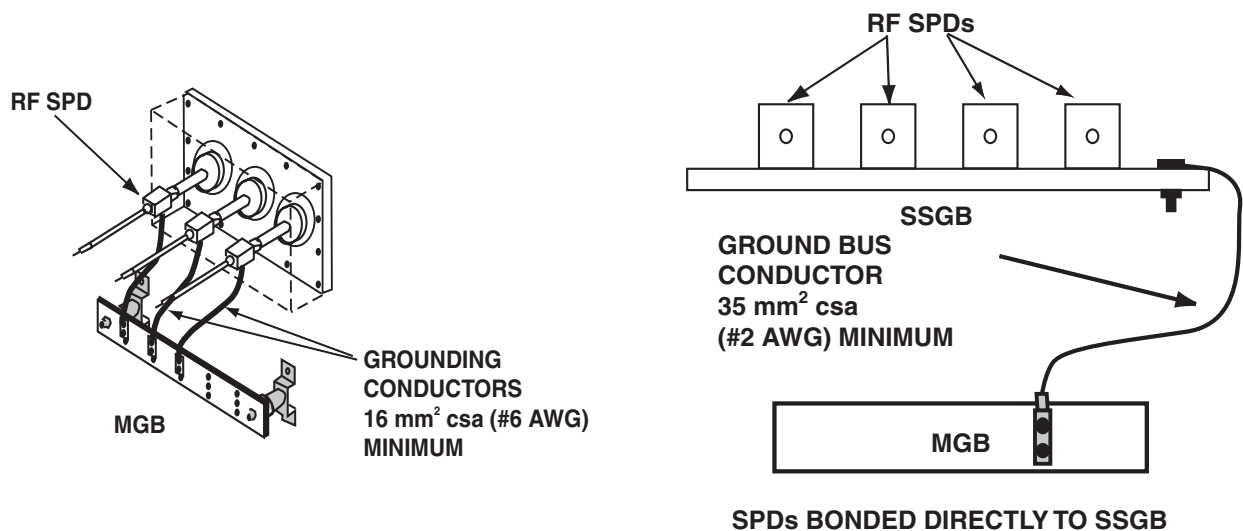

FIGURE 5-31 RF SPD BONDING TO SSGb WITH GROUNDING CONDUCTOR

If RF transmission lines enter the building at a point other than where the equipment room or area is located, there is no requirement for SPDs to be installed at that location. The shield of the RF transmission line **shall** be effectively bonded to the grounding electrode system at the point of entry into the building or as near as practicable thereto (NFPA-70-2005, Article 820.93).

Where a RF transmission line SPD is placed at the equipment shelter, equipment room or equipment area entry point and that entry point is greater than 6.1 linear metres (20 linear feet) away from the MGB's grounding electrode conductor connection to the grounding electrode system, a grounding electrode conductor **shall** properly installed between the SPD and the nearest accessible location of the common grounding electrode system as covered under NFPA 70-2005, Articles 810.21 and 820.100. The SPD **shall** also be effectively bonded back to the MGB by way of its SSGB or a ground bus conductor.

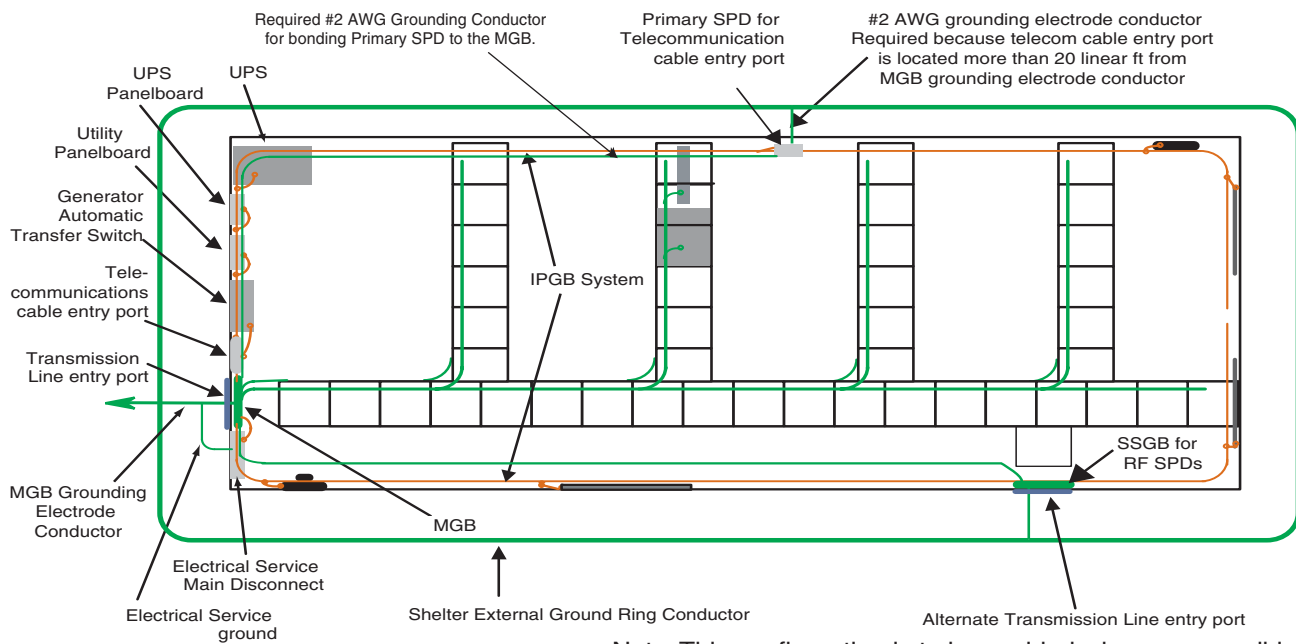

FIGURE 5-32 CABLE ENTRY GREATER THAN 6.1 LINEAR METRES (20 LINEAR FEET) FROM MGB GROUNDING ELECTRODE SYSTEM.

5.5.1.8.2 PRIMARY SURGE PROTECTION DEVICES

Primary SPDs for telephone circuits, data circuits, and control circuits **shall** have the ground (earth) terminal bonded to the MGB, SSGB or a dedicated ground bus conductor with an equipment grounding conductor using bonding methods described within this chapter. The grounding conductor for a single line primary SPD **shall** be 6 mm^2 csa (# 10 AWG) or coarser; the grounding conductor for multiple line primary SPDs **shall** be 16 mm^2 csa (# 6 AWG) or coarser. Where a primary SPD is placed at an entry point other than adjacent to the MGB and that point is greater than 6.1 linear metres (20 linear feet) away from the MGB's grounding electrode, a grounding electrode conductor **shall** properly installed between the primary SPD grounding terminal or its SSGB to the nearest accessible location on the common grounding electrode system as covered under NFPA 70-2005, Articles 800.100, 830.100. See Figure 5-32 for an example of this type of grounding configuration. In both cases, the conductors should maintain a minimum 305 mm (1 ft.) separation between cables of different cable groups, even when conductor is placed in rigid metallic conduit (ANSI-J-STD-607-A-2002).

5.5.1.8.3 SECONDARY SURGE PROTECTION DEVICES

All secondary SPDs **shall** be located as near as practical to the equipment they are protecting. A separate equipment grounding (earthing) conductor **shall** be used to bond each secondary SPD grounding conductor or ground terminal to the MGB, SSGB, RGB, or ground bus conductor that serves the associated equipment. The grounding conductor for a single line secondary SPD **shall** be 6 mm² csa (# 10 AWG) or coarser; the grounding conductor for multiple line secondary SPDs **shall** be 16 mm² csa (# 6 AWG) or coarser. When several secondary SPDs are installed at an equipment rack or cabinet, the SPDs should be placed at a central location within the rack or cabinet so they can be effectively bonded back to the equipment rack or cabinet RGB or back to a separately installed RGB. If a separate RGB is installed for the SPDs, it **shall** be effectively bonded back to the equipment ground bus system using bonding methods described in this chapter.

5.5.1.8.4 TELECOMMUNICATION CABLE METALLIC SHIELDS

Telecommunication cable metallic shields **shall** be bonded to the site's grounding electrode system as described herein. Where outside facility telecommunication cables are configured for a standard entrance, the metallic members of all incoming telecommunication cables, including paired-conductor and optical fiber cable, **shall** be grounded (earthed) to the MGB, either directly or through a SSGB at the facility's entrance point. Each metallic member **shall** be effectively bonded to the grounding point with a 16 mm² csa (#6 AWG) or coarser green-jacketed grounding conductor, or with a transmission line ground kit, using bonding methods described within this chapter. When the internal ground system is configured for functional categories 0 - 7 or PANI, the metallic members **shall** be bonded to reference point 0 or P. (See ANSI T1.313-2003 and paragraph 5.4.3 on page 5-36 for an explanation of PANI grounding.)

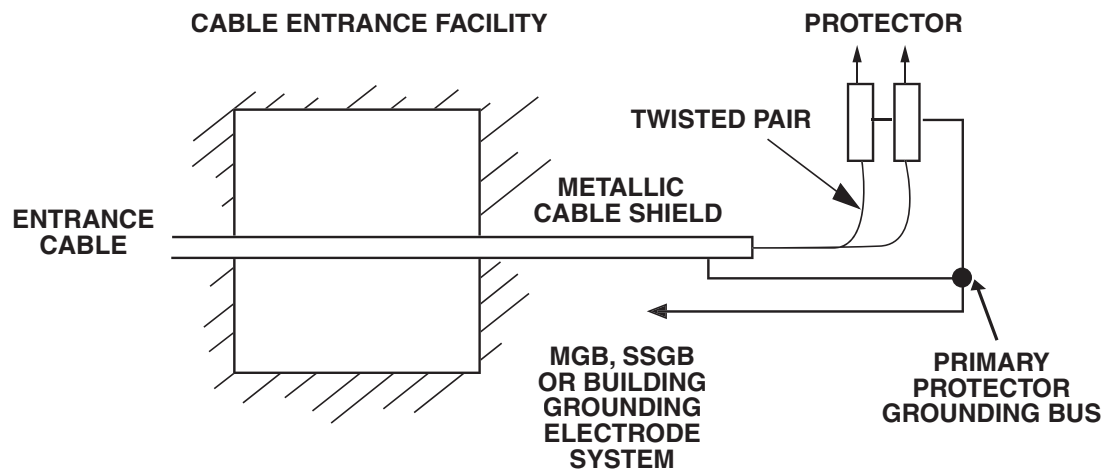

FIGURE 5-33 STANDARD TELECOMMUNICATIONS CABLE ENTRY LOCATION

When outside facility telecommunication cables are configured for an isolation entrance, the metallic member on the field side of the isolation gap **shall** be grounded back to the MGB, either directly or through a SSGB at the facility's entrance point. The bonding point for a PANI configured bus bar will be reference point P. The metallic member on the facility side of the isolation gap **shall** only be bonded at the primary SPD grounding terminal, which is grounded back to the SSGB or to the MGB at the PANI reference point P. In this type environment, the metallic members of all telecommunication cables entering the facility **shall** be isolated with a minimum 76 mm (3 in.) isolation gap. The isolation gap **shall** be sealed and insulated to prevent moisture penetration and flashovers during high voltage events. The grounding conductor for each side of the metallic member **shall** be a 16 mm² csa (#6 AWG) or coarser green-jacketed grounding conductor, and the grounding conductor **shall** be effectively bonded to the referenced grounding point using bonding methods described within this chapter (ANSI T1.313-2003).

NOTE: Isolation gaps, which interrupt the metallic members of all cables, may be installed in some locations as a protective measure against high lightning incidence. This method should be used with caution because it tends to compensate for electrical protection deficiencies in the outside plant (ANSI T1.313-2003). Consultation with a licensed professional engineer is recommended in these instances.

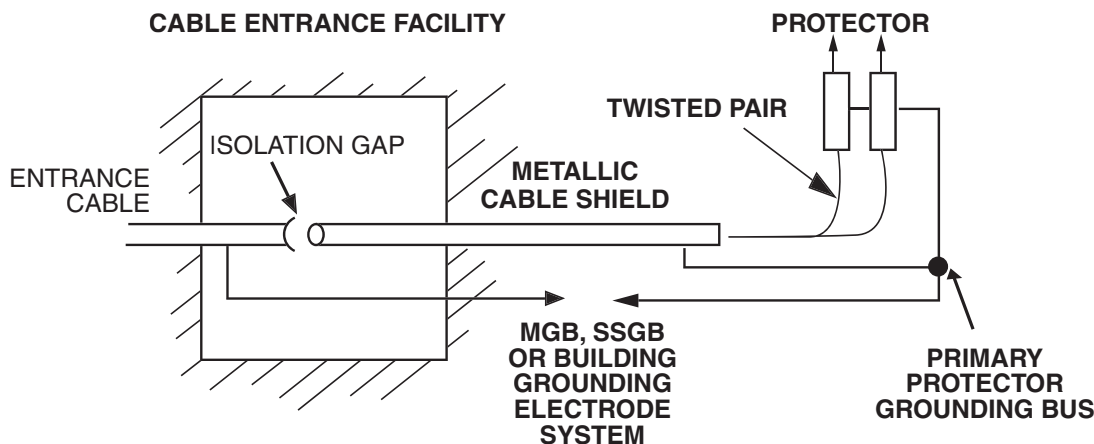

FIGURE 5-34 ISOLATION TYPE TELECOMMUNICATIONS CABLE ENTRY LOCATION

When the outside facility telecommunication cables are configured for an insulating entrance, the metallic members **shall** be bonded on each side of the insulating joint. The facility side of the insulating joint **shall** be bonded back to the MGB, either directly or through a SSGB at the facility's entrance point. The bonding point for a PANI configured bus bar will be reference point P. The grounding conductor for each metallic member on the facility side of the insulating joint **shall** be a 16 mm² csa (#6 AWG) or coarser, green-jacketed, grounding conductor and the grounding conductor **shall** be effectively bonded back the referenced grounding point using bonding methods described within this chapter. On the field side of the insulating joint, all metallic members and all associated metal are deliberately isolated from the site's common grounding electrode system. (See ANSI T1.313-2003 for additional information).

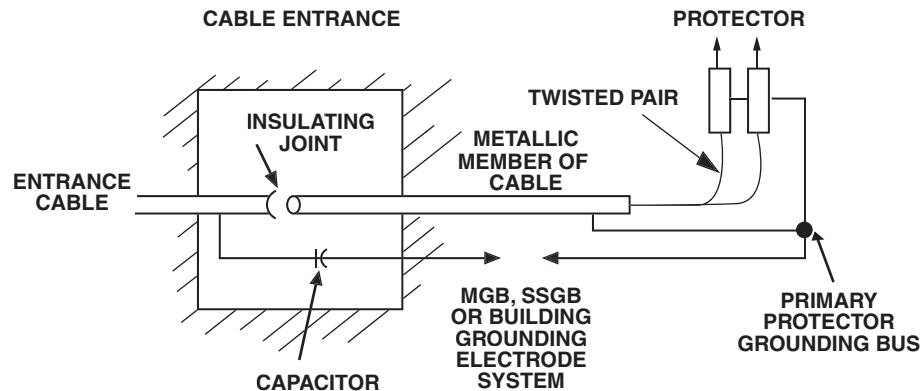

FIGURE 5-35 INSULATING TYPE TELECOMMUNICATIONS CABLE ENTRY LOCATION

Where internal telecommunication cables incorporate a shield or metallic member, the shield or metallic member **shall** be effectively bonded back to the closest MGB or SSGB with a 16 mm² csa (#6 AWG) or coarser, green jacketed, grounding conductor at the point where cables terminate or where they are broken out. Primary SPDs for interbuilding communication cables **shall** be bonded to the MGB or SSGB with a 16 mm² csa (#6 AWG) or coarser, green jacketed, grounding conductor as describe within the chapter. When secondary SPDs are installed at the equipment location, the SPD grounding conductor **shall** be effectively bonded to the closest MGB or SSGB as described within this chapter (ANSI-J-STD-607-A-2002).

5.5.1.8.5 METALLIC SHIELDS FOR INTERNALLY ROUTED SIGNAL CARRYING CABLES

The metallic shields of shielded RS-232 cables or similar type internally routed signal carrying cables **shall** be grounded (earthed) at one end only. A common shield ground wire **shall not** be used for input and output signals, for both high level and low level signals, for signal lines and power conductors, or for electronic signal lines and control lines. Where a signal ground (common return) conductor has been included within the cable, the signal ground wire **shall** only be bonded back to the shield at one end. The shield termination **shall** employ a minimum length pigtail between the shield and the shield pin of the connector. The size of the wire **shall** be as large as practical, but **shall not** be less than 1.5 mm² csa (#16 AWG) or the maximum wire size that will fit the connector pin. The unshielded length of signal cable **shall not** exceed 25 mm (1 in.) with a desired goal of not more than 13 mm (0.5 in.). See Figure 5-36 on page 5-53 for an example of the metallic shield grounding. See FAA-STD-019d-2002 for additional information.

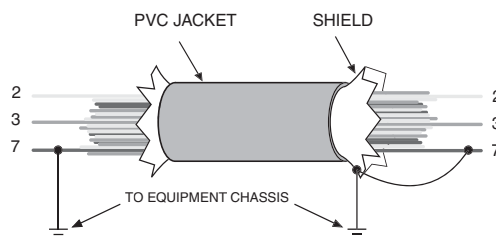

FIGURE 5-36 SIGNAL CABLE SHIELD BONDING

Cables consisting of multiple twisted pairs **shall** have the individual metallic shields isolated from each other. Cables with an overall metallic shield **shall** have the shield insulated. Signal carrying cable shields, individually and collectively, **shall** be isolated from overall shields of cable bundles and from electronic equipment cases, racks, cabinets, junction boxes, conduits, cable trays, and elements of the communications internal grounding system. Except for one interconnection as described above, individual shields **shall** be isolated from each other. This isolation **shall** be maintained in junction boxes, patch panels and distribution boxes throughout the cable run. Where a signal cable is interrupted such as a junction box, the shield **shall** be carried through. The length of unshielded conductors **shall not** exceed 25 mm (1 in.) and the length of the shield bonding conductor **shall** be the minimum required. (See FAA-STD-019d-2002 for additional information.)

Cables that have an overall shield over individually shielded pairs **shall** have the overall shield grounded at each end either directly through the connector or through an SPD. If a SPD is used it **shall** be bonded back to the equipment ground bus system as described within this chapter.

5.6 GROUNDING (EARTHING) FOR STAND-ALONE EQUIPMENT SHELTERS

Stand-alone equipment shelters are normally located next to a communication tower or placed on top of a large building to house the communications system equipment. Equipment located within the stand-alone equipment shelters is often subjected to disturbances from lightning. The information herein addresses the minimum electrical protection, grounding (earthing) and bonding requirements necessary to mitigate the disruptive and damaging effects of lightning on the equipment located within stand-alone shelters.

Not every facility will require the same level of electrical protection that is identified herein. Factors such as those related to telecommunication service reliability or local codes and standards, may dictate the need for electrical protection measures that exceed those described within this chapter.

Internal grounding systems within stand-alone equipment shelters may be configured in several different ways to protect the type of equipment that will be placed within them. It is of utmost importance to ensure that the internal grounding system is properly bonded to the tower or building's external grounding electrode system and that all grounding electrode systems at the location have been properly bonded together into a common grounding electrode system so that no major differences in ground potential exist at the site. See Chapter 4, "External Grounding (Earthing)," for complete information on external grounding.

5.6.1 INSTALLATION REQUIREMENTS FOR STAND-ALONE SHELTERS

The following are the grounding requirements for stand-alone equipment shelter installations:

- All towers, antenna structures, transmission lines, and other outside metallic items associated with the facility **shall** be effectively bonded back to a common grounding electrode system as described in Chapter 4, “External Grounding (Earthing).” (ANSI T1.334-2002, ANSI T1.313-2003, ANSI-J-STD-607-A-2002, NFPA 780-2004, FAA-STD-019d-2002)
- The internal grounding system **shall** have a MGB established within the facility that is effectively bonded to the common grounding electrode system as described in Master Ground (Earth) Bus Bar beginning on page 5-9. (ANSI T1.334-2002, ANSI T1.313-2003, FAA-STD-019d-2002, NFPA 70-2005)
- Where the main electrical service disconnect or the main electrical service panelboard is not installed on the same wall as the transmission line entry port, the MGB **shall** be located as close to the panelboard as practicable and it **shall** be installed to maintain clearances required by applicable electrical codes.
- The grounding electrode conductor for the electrical service neutral to ground bond **shall** be established in the main disconnect and bonded back to the shelter common external grounding electrode system as described within Chapter 4, “External Grounding (Earthing),” and Chapter 6, “Power Sources.” The main disconnect grounding electrode conductor **shall** meet all installation requirements of applicable local and jurisdictional electrical codes (NFPA 70-2005, Article 250.64). Some acceptable examples of the grounding electrode conductors routing and bonding to the common external grounding system are provided in Figure 5-37.
- The electrical service alternating current equipment ground (ACEG) bus (when installed) or the main electrical service enclosure **shall** be bonded to the MGB with a 35 mm² csa (#2 AWG) green jacketed grounding conductor, using UL 486A listed two-hole compression type lug (ANSI T1.334-2002).
- All other communications system power sources **shall** be effectively bonded back to the MGB as described in paragraphs 5.5.1.1 on page 5-42 and 5.5.1.2 on page 5-43. (ANSI T1.334-2002, ANSI T1.313-2003, ANSI T1.333-2001, FAA-STD-019d-2002, NFPA 70-2005.)
- All outside facility telecommunications cables **shall** have their metallic shields properly bonded back to the internal grounding system as described in paragraph 5.5.1.8.4 on page 5-51 (ANSI T1.334-2002, ANSI T1.313-2003, ANSI-J-STD-607-A-2002, FAA-STD-019d-2002, NFPA 70-2005).
- All outside facility telecommunications cable primary SPDs at the facility entrance location **shall** be properly bonded to the internal grounding system as described in paragraph 5.5.1.8.2 on page 5-50 (ANSI T1.334-2002, ANSI T1.313-2003, ANSI-J-STD-607-A-2002, FAA-STD-019d-2002, NFPA 70-2005).
- All transmission lines and coaxial cable RF SPDs at the cable entry location **shall** be bonded to the internal grounding system as described in paragraph 5.5.1.8.1 on page 5-49 (ANSI T1.334-2002, FAA-STD-019d-2002, NFPA 70-2005).
- All externally routed power circuits, tower lighting conductors, video cables, telecommunications, alarm and control cables and RF transmission lines **shall** have SPDs installed as described in Chapter 7, “Surge Protective Devices,” and the SPDs **shall** be effectively bonded back to the external or internal grounding system as described within this chapter (ANSI T1.334-2002; FAA-STD-019d-2002).

- All communications equipment within the facility **shall** be bonded back to the internal grounding system as described in paragraphs 5.5.1.3 and 5.5.1.4 on page 5-44 (ANSI T1.334-2002, ANSI T1.313-2003, ANSI-J-STD-607-A-2002, FAA-STD-019d-2002, NFPA 70-2005).
- All ancillary support apparatus and metallic non-current-carrying items within the facility **shall** be bonded back to the internal grounding system as described in paragraphs 5.4.2 on page 5-34 and 5.5.1.6 on page 5-46 (ANSI T1.334-2002, ANSI T1.313-2003, ANSI-J-STD-607-A-2002, FAA-STD-019d-2002, NFPA 70-2005).
- Where multiple pieces of ancillary support apparatus are bonded back to a perimeter ground bus system, the perimeter ground bus system **shall** meet the installation requirements of an IPGB system as described in paragraph 5.3.7 on page 5-28.
 - **Exception:** Although not preferred, an interior perimeter ground ring system (halo) installed per the requirements of ANSI T1.334-2002 is an acceptable ground bus system for bonding ancillary support apparatus and metallic non-current-carrying items only.

**CAUTION****Electronic equipment shall not be bonded to the internal perimeter ground ring.**

- If used, an interior perimeter ground ring system **shall** meet the following installation requirements:
 - All communications equipment within the facility **shall** be bonded to the internal grounding system as described within this chapter (ANSI T1.334-2002, ANSI T1.313-2003, ANSI-J-STD-607-A-2002, FAA-STD-019d-2002, NFPA 70-2005).
 - The interior perimeter ground ring **shall** be constructed of 35 mm² csa (#2 AWG) or coarser copper conductor.
 - The interior perimeter ground ring **shall** be located 305 mm (1 ft.) from the ceiling where practical.
 - The interior perimeter ground ring should be one continuous conductor bonded together with exothermic weld or irreversible compression connection.
 - The interior perimeter ground ring **shall** be supported at approximately 610 mm (2 ft.) intervals by standoff supports.
 - Minimum bending radius of the interior perimeter ground ring conductor **shall** be 305 mm (1 ft.).
 - The interior perimeter ground ring conductor **shall** be bonded to the exterior ground ring with 35 mm² csa (#2 AWG) or coarser solid tinned copper conductors.
 - A grounding electrode conductor **shall** be placed at each corner of the shelter and bonded to the interior perimeter ground ring and exterior ground ring conductors with exothermically welded connections or irreversible compression connections.
 - If the length of the interior perimeter ground ring conductor exceeds 15 m (50 ft.) between the corner bonds, additional grounding electrode conductors to the exterior ground ring **shall** be placed at approximately equal intervals between the corner bonds.
 - The interior perimeter ground ring conductor **shall** be bonded to the MGB with a 35 mm² csa (#2 AWG) or coarser copper conductor.

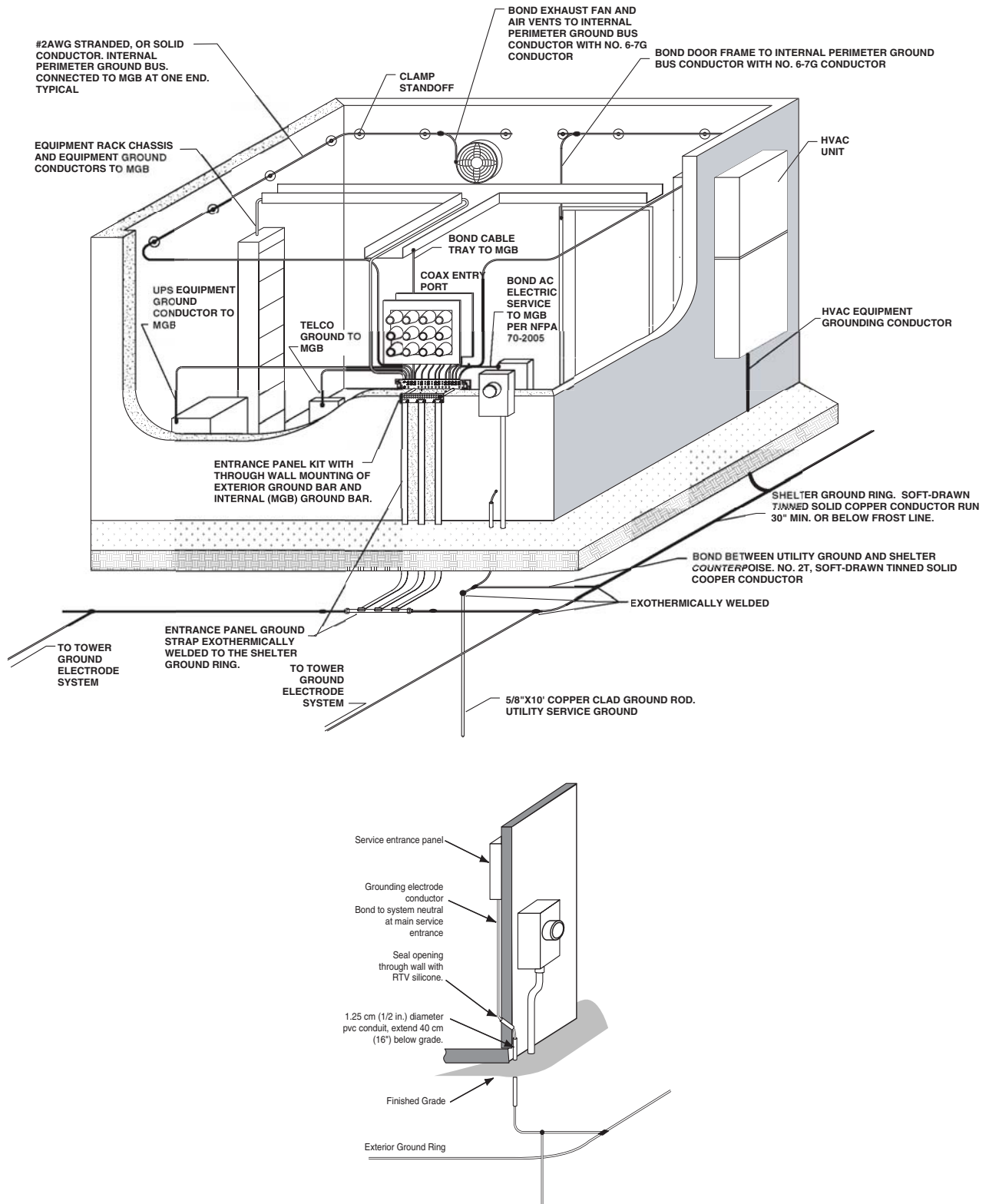

FIGURE 5-37 ROUTING OF ELECTRICAL GROUNDING ELECTRODE CONDUCTOR

5.7 GROUNDING (EARTHING) FOR SMALL, LARGE, AND MULTI-STORY BUILDINGS

Building infrastructure encompasses telecommunication spaces, pathway, cables, connecting hardware, and the telecommunication grounding (earthing) and bonding system (ANSI-J-STD-607-A-2002). The information herein specifies the requirements for establishing a uniform communication grounding system within a small, large or multistory building when an internal grounding system does not exist. For additional information, see ANSI-J-STD-607-A-2002.

5.7.1 ESTABLISHING A COMMUNICATION GROUNDING (EARTHING) SYSTEM

A MGB **shall** be properly installed as described herein and within “General Bonding Requirements” on page 5-31. The MGB serves as the dedicated extension of the building grounding (earthing) electrode system for the communication systems throughout the building. It also serves as a central attachment point for the communication bonding backbone conductor(s) and the equipment. There should only be a single MGB installed within the building. The following paragraphs are requirements of ANSI-J-STD-607-A-2002.

NOTE: Buildings or campuses with more than one electrical service entrance, each of which serves the communication system, require special design considerations that are beyond the scope of this document. Consultation with Motorola Engineering or with an engineering firm specializing in grounding system design is recommended in the instances.

The MGB **shall** be bonded back to the service equipment (power) ground with the shortest and straightest routing possible. The MGB grounding conductor should be routed to provide a direct downward flow path back to the building's grounding electrode system. If a bend is required in the MGB grounding conductor, minimum bending radius and angle **shall** be adhered to.

The ideal location for the MGB is in the telecommunications entrance facility, however the MGB should be located to minimize the length of the MGB grounding conductor back to the electrical service (power) ground where the electrical service neutral to ground bond has been established. When a panelboard is located within the same room as the MGB, the MGB **shall** be located as close to the panelboard as practicable and it **shall** be installed to maintain clearances required by applicable electrical codes. The MGB should also be located to provide the shortest and straightest routing for the telecommunications primary SPD grounding conductor. See Figure 5-38 for an example.

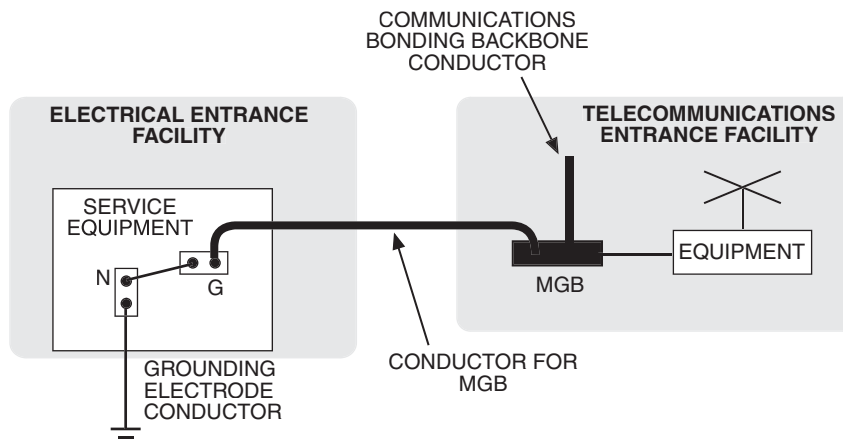

FIGURE 5-38 BONDING TO THE ELECTRICAL SERVICE (POWER) GROUND

At locations where communication bonding backbone conductors are used to interconnect multiple equipment rooms together, the communication bonding backbone conductors **shall** meet the installation requirements as specified in paragraph 5.3.6 on page 5-25. While the communication bonding backbone conductor will carry fault current under AC power ground fault conditions, it is not intended to serve as the only conductor providing a ground fault current return path.

SSGBs **shall** be installed as described herein and within paragraph 5.3.2 beginning on page 5-15. A main SSGB **shall** be placed in each communications equipment room or space as needed to keep equipment ground bus conductors or equipment grounding conductors as short as practicable. If a bend is required in the SSGB grounding conductor, minimum bending radius and angle **shall** be considered. When a panelboard for the communications equipment is located within the same room or space as the main SSGB, the SSGB **shall** be located as close to the panelboard as practicable and **shall** be installed to maintain clearances as required by applicable electrical codes.

5.7.2 SPECIFICATIONS FOR CONDUCTORS

All grounding (earthing) and bonding conductors **shall** be copper and may be insulated. When the conductors are insulated, they **shall** be listed for the space in which they are intended to be placed. See paragraph 5.3.4 beginning on page 5-20 for information on grounding conductor specifications.

All grounding and bonding conductors **shall** be sized according to their functions. Grounding conductor sizing specifications are located in the following sections:

- Ground bus conductors: paragraph 5.3.5.2 on page 5-25
- Communication bonding backbone conductors: paragraph 5.3.6.2 on page 5-26
- IPGB conductors: paragraph 5.3.7.2 on page 5-29
- Equipment grounding conductors: paragraph 5.3.8.2 on page 5-29
- Bonding jumpers: paragraph 5.3.9.2 on page 5-30

NOTE: Conductors installed within a plenum **shall** be compliant with NFPA 70-2005, Article 300.22 and cables installed within Information Technology rooms **shall** be compliant with NFPA 70-2005, Article 645. Ground conductors **shall** have an approved covering (insulation) or may be bare. When bare conductors are used they **shall** be solidly supported on suitable standoff insulators at intervals of no more than 610 mm (24 in.). These conductors **shall not** make contact with metallic surfaces or other conductors unless intended to be bonded to these surfaces or conductors.

NOTE: The interior water piping systems of the building and metallic cable shields **shall not** be used as communication bonding backbone conductors (ANSI-J-STD-607-A-2002).

In all cases, the main SSGB **shall** be bonded to the communication bonding backbone conductor or grounding equalizer conductor with a conductor the same size as the communication bonding backbone conductor. The MGB grounding conductor for the service equipment (power) ground **shall** be, at a minimum, the same size as the communication bonding backbone conductor (ANSI-J-STD-607-A-2002).

5.7.3 BONDING CONNECTIONS FOR THE MGB

The connection of the MGB grounding (earthing) conductor, the communication bonding backbone conductor(s) and ground bus conductors to the MGB **shall** utilize exothermic welding, listed compression two-hole lugs, or irreversible compression type connections. The connection of equipment grounding conductors that bond communications equipment to the MGB **shall** utilize exothermic welding, listed compression single-hole lugs, or other irreversible compression type connections. Two-hole lugs are preferred over single-hole lugs (ANSI-J-STD-607-A-2002).

NOTE: All grounding and bonding connectors **shall** be listed for the application by a nationally recognized testing laboratory (ANSI-J-STD-607-A-2002).

The MGB grounding conductor **shall** be bonded to the building's common grounding electrode system as described in paragraph 5.3.1.3 on page 5-12.

5.7.4 BONDING CONNECTIONS FOR THE SSGB

The grounding (earthing) conductor between the main SSGB and the communication bonding backbone conductor **shall** be continuous and routed in the shortest possible straight line path back towards the MGB. If a bend is required in the SSGB grounding conductor, minimum bending radius and angle **shall** be adhered to. The grounding conductor **shall** be connected to the SSGB with exothermic welding, compression two hole lug, or an irreversible compression type connector. The SSGB grounding conductor **shall** be connected to the communication bonding backbone conductor or to the grounding equalizer conductor with exothermic welding or irreversible compression-type connection. The connection of equipment grounding conductors for bonding communications equipment to the SSGB **shall** utilize exothermic welding, listed compression single-hole lugs, or other irreversible compression type connections. Two-hole lugs are preferred over single hole-lugs (ANSI-J-STD-607-A-2002)

NOTE: All grounding and bonding connectors **shall** be listed for the application by a nationally recognized testing laboratory (ANSI-J-STD-607-A-2002).

When a grounding equalizer conductor is bonded to a main SSGB, the grounding equalizer conductor **shall** be connected to the SSGB using exothermic welding, compression two-hole lugs, or irreversible compression type connections.

5.7.5 ITEMS TO BE BONDED TO THE INTERNAL GROUND (EARTH) SYSTEM

See ANSI-J-STD-607-A-2002 for additional information. When an electrical power panelboard is located in the same room or space as the MGB or SSGB, that panelboard's alternating current equipment ground (earth) (ACEG) bus or the panelboard enclosure **shall** be effectively bonded to the MGB or the SSGB with a 16 mm² csa (#6 AWG) or coarser grounding conductor. Where a panelboard for the communications equipment is not located in the same room or space as the SSGB, consideration should be given to bonding panelboard ACEG bus or the panelboard enclosure back to the SSGB with a properly sized grounding conductor. In all cases the grounding conductor should be sized according to its length in accordance with the requirements in Table 5-5 on page 5-29.

All metallic raceways or cable trays for telecommunication cabling that is located within the same room or space as the MGB or a main SSGB **shall** be effectively bonded back to the MGB or the SSGB with a 16 mm² csa (#6 AWG) or coarser, grounding conductor as described in paragraph 5.5.1.5 on page 5-45.

When structural building steel is readily accessible within the room of a MGB or main SSGB, the MGB and/or SSGB **shall** be effectively bonded to the vertical steel frame with a 16 mm² csa (#6 AWG) or coarser, grounding conductor by following bonding methods in paragraphs 5.4.2 on page 5-34 and 5.4.3 on page 5-36. If the structural steel frame is external to the room or space of the MGB or SSGB and readily accessible, the steel frame should be bonded back to the MGB or SSGB with a 16 mm² csa (#6 AWG) or coarser, grounding conductor as described above. The MGB or SSGB grounding conductor **shall** be bonded to the vertical steel column, routed downward toward the earth's surface. When practicable because of shorter conductor runs and where horizontal steel members of the building frame are permanently and electrically bonded to the vertical column members, the SSGBs may be bonded to the horizontal members. The grounding conductor should be sized according to its length as shown in Table 5-5 on page 5-29, and if a bend is required in the grounding conductor, minimum bending radius and angle **shall** be adhered to.

The telecommunications primary SPD grounding conductor **shall** be connected to the MGB using the shortest and straightest routing path practical. A minimum separation distance of 305 mm (1ft) **shall** be maintained between other cable groups even if the conductor is routed inside a metallic conduit. See paragraph 5.5.1.8.2 on page 5-50 for additional information.

At the location where telecommunications cabling enters the building, the metallic shields **shall** be bonded to the building's grounding system by one of the methods described in paragraph 5.5.1.8.4 beginning on page 5-51. Where internal backbone telecommunication cables (telephone system cables) incorporate a shield or metallic member, the shield or metallic member **shall** be effectively bonded to the closest MGB or main SSGB with a 16 mm² csa (#6 AWG) or coarser green jacketed grounding conductor at the point where cables terminate or where they are broken out. Primary SPDs for inter-building communication cables **shall** be bonded to the MGB or SSGB with a 16 mm² csa (#6 AWG) or coarser, green jacketed grounding conductor as described in paragraph 5.5.1.8.2 on page 5-50. When secondary SPDs are installed at the equipment location, the SPD grounding conductor **shall** be effectively bonded to the closest MGB or SSGB as described in paragraph 5.5.1.8.3 on page 5-51.

Where external antenna cables enter the building, that point of entry **shall** be treated as a cable entrance location (ANSI-J-STD-607-A-2002). The cable entrance location **shall** have an accessible bonding location to the building's common grounding electrode system (e.g., an external ground bus bar or structural building steel). The outer metallic shields of each transmission line and other communications cables **shall** be bonded to the building's common grounding electrode system (NFPA 70-2005, Articles 770.93, 800.100, 810.20, 820.93, 820.100, and 830.100). See "External Ground Bus Bar" on page 4-30 for additional information.

5.8 GROUNDING (EARTHING) FOR DISPATCH CENTERS AND NETWORK OPERATOR POSITIONS

Dispatch centers co-located with communication towers require special protection considerations due to the critical nature of their operation and due to the inherent risk to personnel from lightning events. For optimum protection of a dispatch center, the following **shall** be considered:

- Site design recommendations given in "Design Considerations to Help Reduce Effects of Lightning" on page 2-19.
- External grounding (earthing) and bonding as defined in Chapter 4, "External Grounding (Earthing)."
- Transient voltage surge suppression (TVSS) as defined in "Telephone/Control/Data Network Circuit SPDs" on page 7-34.
- Electrostatic discharge (ESD) precautions as defined in Appendix C.

This section provides electrical protection measures that are intended to help protect network operators, and to help ensure reliable equipment operation during periods of lightning activity or surges from AC power lines and power switching operations.

5.8.1 GROUNDING (EARTHING) AND PROTECTION OF INCOMING POWER AND TELECOMMUNICATION CABLES

To minimize the effects of lightning and AC power surges at the facility, a common internal grounding (earthing) system **shall** be installed as described in “Grounding (Earthing) for Small, Large, and Multi-Story Buildings” on page 5-58. Applicable surge protection devices **shall** be installed on all incoming power lines and telecommunication cables as described in Chapter 7, “Surge Protective Devices,” and the surge protection devices **shall** be effectively bonded back to the common internal grounding system as described in this chapter. All outside facility telecommunication cables entering the building and their surge protection devices **shall** be effectively bonded back to the internal grounding electrode system as described within this chapter.

Any co-located Lightning Protection System (LPS), communication tower, or outside mounted antenna **shall** also be effectively bonded back to the site's common grounding electrode system as described in Chapter 4, “External Grounding (Earthing).”

5.8.2 GROUNDING (EARTHING) OF EQUIPMENT ROOMS LOCATED WITHIN THE DISPATCH CENTER

All communications system equipment rooms located in the same building and fed by the same electrical service **shall** have a single point grounding (earthing) location established within the room or space. This location can be the communications system MGB, an SSGB, or a properly sized ground bus conductor. In all cases, the single point grounding location **shall** be effectively bonded back to the communications system common internal grounding system as described within this chapter.

NOTE: Buildings or campuses with more than one electrical service entrance, each of which serves the communication system, require special design considerations that are beyond the scope of this manual. Consultation with Motorola Engineering or with an engineering firm specializing in grounding system design is recommended in these instances.

All interconnect communications system equipment and ancillary support equipment located within the communication equipment room **shall** be effectively bonded back to the single point grounding location in accordance with the requirements within paragraphs 5.5.1.3 and 5.5.1.4 on page 5-44, and 5.5.1.6 on page 5-46.

All voltage limiting SPDs located within the communication equipment room **shall** be effectively bonded to the single point grounding location in accordance with paragraph 5.5.1.8 and the associated paragraphs beginning on page 5-49.

5.8.3 GROUNDING (EARTHING) AND PROTECTION OF NETWORK OPERATOR POSITIONS AND WORK AREAS

When a network operator location is not properly protected, electrical disturbances may appear at the work position that could possibly harm the operator and/or damage the equipment. These electrical disturbances can arise from sources external or internal to the building such as lightning, ac power disturbances, or electrostatic discharge (ESD). To adequately protect the operator and the equipment at the position, an adequate grounding (earthing) system and the required surge suppression devices **shall** be installed as described within this chapter.

Equipotential bonding at the network operator position is essential in providing personnel safety and equipment reliability. A network operator position often contains a headset, headset interface equipment, and other electronic equipment such as consoles, computers, video displays, small emergency radios, and furniture. Work positions are frequently arranged in clusters within a dispatch room and the operator equipment is interconnected with other communication system equipment located throughout the building. In these instances, it is not only important to establish equipotential bonding at the operator position, it is also necessary to establish it between any adjacent operator positions. The ground potential **shall** also be equalized between any interconnected communication systems within the building that are fed by the same electrical service.

5.8.3.1 EQUIPOTENTIAL GROUNDING (EARTHING) OF THE NETWORK OPERATOR POSITION

All network operator equipment, including but not limited to the items listed below, **shall** be effectively bonded back to the communication systems MGB using methods described within this chapter. See ANSI T1.321-R2000 for additional information.

- Equipment supplied with a ground (earth) connection point
- Mounting rails or support brackets intended for mounting equipment on or within the furniture
- Metallic parts of network operator furniture
- Telecommunication cable shields
- Data cable shields
- Voltage limiting secondary surge protection devices

A SSGB **shall** be installed at the network operator position area. If several network operator positions are arranged in a cluster, a single SSGB may be shared at each cluster, provided equipment grounding conductor length restriction can be met.

Each network operator position SSGB **shall** be effectively bonded back to the MGB or a common collection point SSGB within the area or space, using an adequately sized ground bus conductor.

The ground bus conductor **shall** be as short and straight as practical and **shall** be bonded to the SSGBs using the connection methods described in paragraph 5.4.4 on page 5-38. See Table 5-3 and Table 5-4 on page 5-27 for ground bus conductor sizing requirements. When used, the main collection point SSGB for the dispatch room **shall** be bonded back to the communication bonding backbone conductor as described within this chapter.

All bonding connections at the network operator position or cluster of positions **shall** be terminated on the SSGB. The SSGB **shall** be located so that the equipment grounding conductor length is as short as possible. In order to keep inductance low, all equipment grounding conductors **shall** be kept as short and straight as practicable. Equipment grounding conductors **shall not** be coiled or looped.

All metallic equipment enclosures, frames, and chassis, as well as the operator position furniture (other than chairs) **shall** be effectively bonded to the SSGB using conductors as follows:

- 16 mm² csa (#6 AWG) insulated copper conductor for lengths not exceeding 3.9 m (13 ft.).
- 6 mm² csa (#10 AWG) insulated copper conductor for lengths not exceeding 3 m (10 ft.).
- If a longer length is required, the equipment grounding conductor should be sized according to Table 5-5 on page 5-29.

Equipment mounting rails or support brackets intended for mounting equipment within the furniture **shall** be bonded to the ground system by attaching a 16 mm² csa (#6 AWG) insulated copper conductor to a single mounting rail or bracket. In instances where an equipment chassis or housing is installed between mounting brackets or rails and the equipment chassis or housing has a designated ground connection point, an additional equipment grounding conductor **shall** be attached to the designated grounding connection point of the equipment.

Equipotential bonding at a network operator position should be integrated into the position equipment to the greatest extent possible. This will largely reduce the need to place equipment grounding conductors. All telecommunication cable shields, data cable shields, and the equipment or furniture AC equipment ground (ACEG) **shall** be bonded together at the position SSGB or within the equipment.

Outer shields of telecommunication cables serving the network operator position or cluster of positions (to or from a different location) **shall** be bonded directly to the SSGB or by using conductors as follows:

- 16 mm² csa (#6 AWG) insulated copper conductor for lengths not exceeding 3.9 m (13 ft.).
- 6 mm² csa (#10 AWG) insulated copper conductor for lengths not exceeding 1.8 m (6 ft.).

The outer shield ground is provided automatically when the cable connector contains a shield-to-chassis connection.

When AC power is present at a network operator position, the AC power receptacle housing or ACEG **shall** bond to the SSGB using a conductor as follows:

- 6 mm² csa (#10 AWG) insulated copper conductor for lengths not exceeding 914 mm (3 ft.)
- 16 mm² csa (#6 AWG) insulated copper conductor for length exceeding 914 mm (3 ft.)

The conduit or raceway serving the receptacle box **shall not** be relied upon as the sole ACEG at the position. A separate, insulated ACEG conductor **shall** be run with the branch circuit supply conductors, and **shall** be properly bonded to the metallic receptacle box, conduit or armored cable per the requirements of NFPA 70-2005. The ACEG conductors of AC branch circuits serving network operator equipment positions **shall not** be electrically isolated from the building grounding and bonding network in any way. Due to the required bonding of the ACEG conductor to the SSGB, isolated ground receptacles **shall not** be used (ANSI T1.321-R2000).

Exposed metallic objects located within 2.4 m (8 ft.) vertically or 1.5 m (5 ft.) horizontally from the operator position (such as building steel, ventilation ducts, and the nearest raised flooring system support pedestal) **shall** be effectively bonded to the operator position SSGB with a minimum 16 mm² csa (#6 AWG) copper conductor of the shortest and straightest length possible.

Surge protection devices should be present on all AC power, telephone and data communication cables at every network operator position or cluster to help minimize voltages between communication conductors and conductive surfaces (see Chapter 7, “Surge Protective Devices”). When SPDs are present, they **shall** be bonded to the SSGB using conductors as follows:

- 6 mm² csa (#10 AWG) insulated copper conductor for lengths not exceeding 914 mm (3 ft.).
- 16 mm² csa (#6 AWG) insulated copper conductor for lengths not exceeding 3.9 m (13 ft.).

The grounding conductors **shall** be run using the shortest, most direct route as practicable.

See Figure 5-39 for a high level overview of the required bonding.

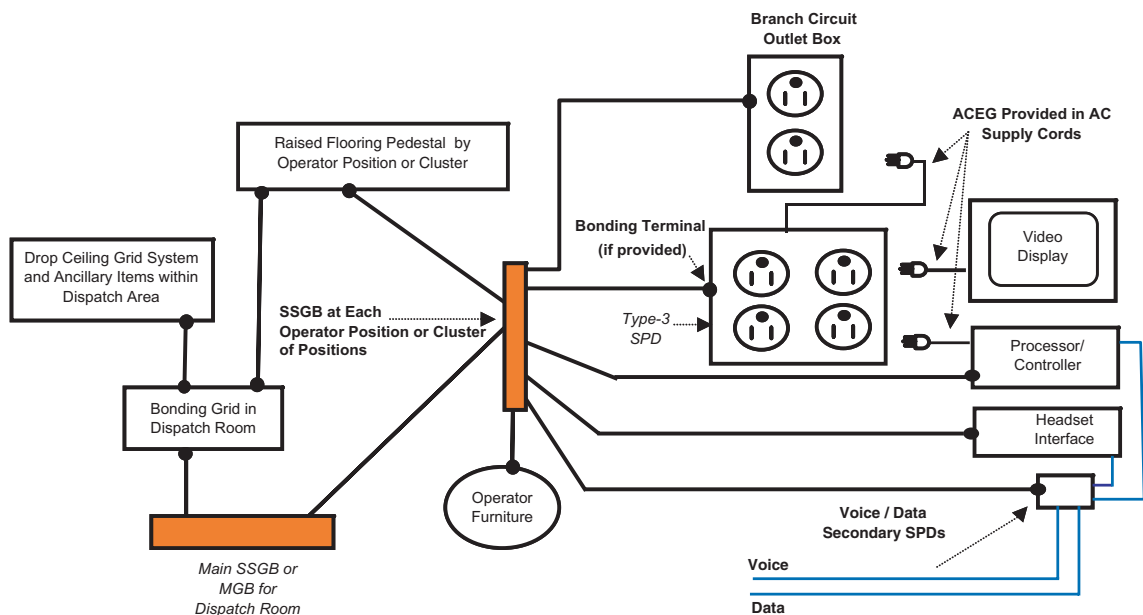

FIGURE 5-39 EXAMPLE OF NETWORK OPERATOR POSITION GROUNDING

5.8.3.2 INTERPOSITION BONDING FOR MULTI-CLUSTER NETWORK OPERATOR POSITIONS

When a dispatch room is configured with multiple network operator position clusters, consideration should be given to establishing a bonding grid that interconnects all network operator position SSGBs and equalizes potentials among the clusters. This bonding grid will be of value if an operator of one cluster, while still connected to his or her own position, approaches a position in an adjacent neighboring cluster. When a bonding grid is installed it **shall** meet the requirements of this paragraph. See Figure 5-40 and Figure 5-41 on page 5-67 for examples.

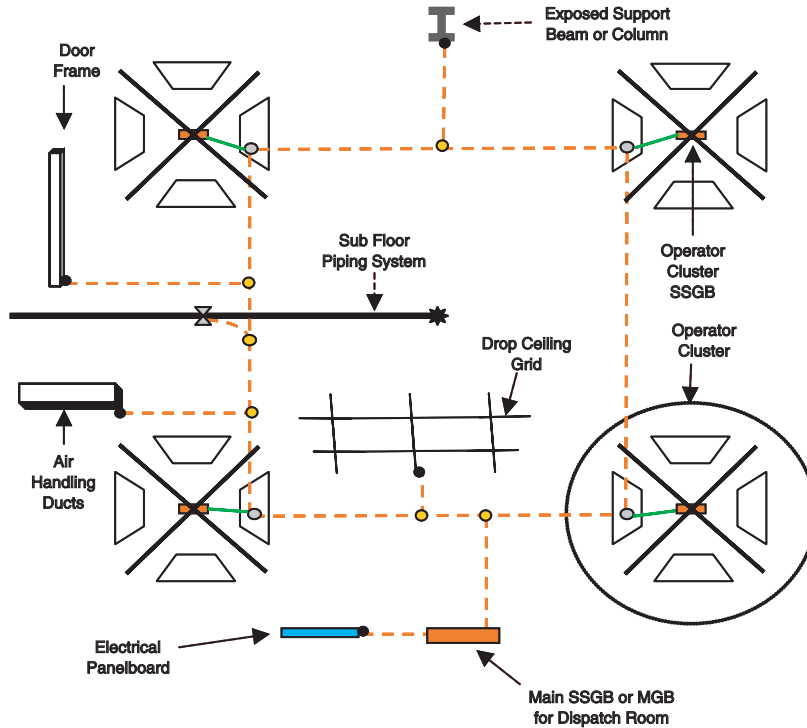

FIGURE 5-40 RAISED FLOORING GROUNDING GRID, SHOWING BONDING OF ANCILLARY SUPPORT APPARATUS TO THE BONDING GRID

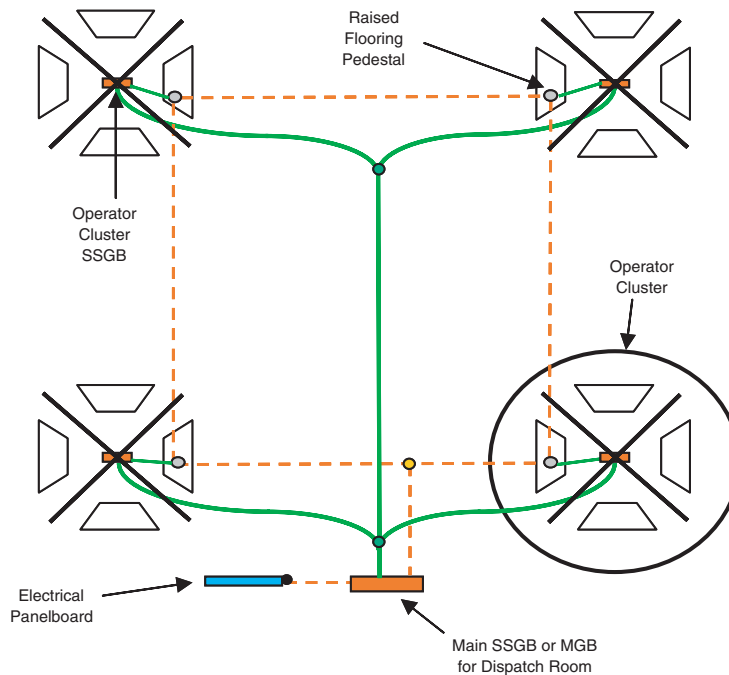

FIGURE 5-41 RAISED FLOOR GROUNDING GRID AND NETWORK OPERATOR EQUIPMENT GROUND BUS SYSTEM

If a bonding grid is present, it should be used to bond the raised flooring system supports at each grid node location and suspended ceiling grids, in at least four places, preferably at the corners of the dispatch area, using bonding methods described in this chapter. Other items such as electrical panelboards, metallic water fountains, metallic plumbing, metallic ventilation ducts and other metallic ancillary support items **shall** be bonded back to the nearest bonding grid conductor with a minimum 16 mm² csa (#6 AWG) copper conductor of the shortest length possible.

The bonding grid should be established within the same space used to run electrical power and communication cables to the operator positions. This space can be below a raised flooring system that supports the operator positions, the space immediately below the structural floor supporting the operator positions, or the space above a suspended ceiling grid system when a raised flooring system has not been installed (ANSI T1.321-R2000).

The bonding grid **shall** be made from 16 mm² csa (#6 AWG) or coarser stranded copper conductor that may be jacketed as allowed by the space where it will be installed. The grid node connections **shall** be made using irreversible compression-type connections that are listed for the purpose. Each grid node connection should be positioned vertically below or above (ceiling area) each cluster SSGB. The grid nodes may be established with horizontal offsets of 1.5 m (5 ft.) or less from a cluster. Each cluster SSGB **shall** be connected to its associated grid node with a minimum 16 mm² csa (#6 AWG) copper conductor of the shortest and straightest length possible. The SSGB grounding conductor **shall** be no greater than 3.9 m (13 ft.) in length. If greater lengths are needed, the SSGB grounding conductors and the bonding grid conductor **shall** be sized up to 35 mm² csa (#2 AWG).

The bonding grid **shall** be effectively bonded to the dispatch room main collection point SSGB or MGB with a copper bonding conductor of the same size as the bonding grid conductor. This bonding conductor **shall** be bonded to the nearest bonding grid conductor with an exothermically welded or an irreversible compression-type connection. The conductor **shall** be bonded to the SSGB or MGB with exothermic welding, irreversible compression two-hole lug, or other irreversible compression means.

5.9 GROUNDING (EARTHING) FOR INTEGRATED COMMUNICATION SITES

For communications sites located on the rooftop or within a high-rise building whose primary purpose is something other than a communications site, connection of the communications internal grounding (earthing) system **shall** be made to the building's common grounding electrode system as described herein and within this chapter.

The information within this section specifies the requirements for establishing an integrated communications site grounding system on or within a high-rise building where an internal grounding system does not exist. When communications equipment is located on or within a building with an established grounding system, the communications equipment **shall** be effectively bonded back the common bonding network (CNB) for the building. See ANSI T1-313-2003 and ANSI T1.333-2001 for additional information on bonding to the building CBN.

At high-rise sites, connection to effectively grounded structural building steel is the preferred connection location for the equipment room MGB. In poured concrete buildings where structural building steel may not be an option, effectively grounded and accessible rebar may be considered for use as a connection point. If these options are not available, use the other methods recommended within this section.

An adequately sized MGB **shall** be installed within the equipment area by following the requirements in paragraphs 5.3.1 on page 5-9, 5.3.1.1 on page 5-9, 5.3.1.2 on page 5-11, and 5.3.1.3 on page 5-12. The MGB **shall** be effectively bonded to the nearest accessible location on the building's common grounding electrode system. Bonding of the MGB to the building's common grounding electrode **shall** be made using one or more of the following recommendations below:

IMPORTANT: At sites, such as high-rise buildings, where it is difficult to achieve an effective grounding electrode system, the need for single-point grounding and transient voltage surge suppression (TVSS) on all input/outputs is of paramount importance.

- Bonding to an existing building grounding backbone-type system.
- Installation of a bonding backbone conductor(s) as described in “Communication Bonding Backbone Conductor and Grounding (Earthing) Equalizer Conductors” on page 5-25.
 - Grounding conductor **shall** be run in as straight a line as is practical (NFPA 70-2005, Article 810.21(E) and ANSI T1.313-2003) and **shall** be run in a downward direction.
 - Minimum bend radius of grounding conductors **shall** be 203 mm (8 in.), and the included angle **shall not** exceed 90 degrees as shown in Figure 5-13 on page 5-19 (NFPA 780-2004, Section 4.9.5 and ANSI T1.313-2003).
 - Grounding conductors **shall** be permitted to be run either outside or inside the building or structure (NFPA 70-2005, Article 810.21(G)).
 - Grounding conductors **shall** be protected where exposed to physical damage (NFPA 70-2005, articles 250.64, 800.100, 810.20, 820.100; and NFPA 780-2004, section 4.9.11).
 - Grounding conductors **shall** be securely fastened at intervals not exceeding 914 mm (3 ft.) (ANSI T1.334-2002, section 8.3 and NFPA 780-2004, Section 4.10.)
 - Grounding conductors exposed to physical damage **shall** be protected for a minimum distance of 1.8 m (6 ft.) above grade level (NFPA 780-2004, section 4.9.11.2). Such areas may include, but are not limited to, runways, driveways, school playgrounds, cattle yards, public walks (NFPA 780-2004, section 4.9.11).
- Bonding to effectively grounded metallic piping systems under the advice of the building engineer.

NOTE: Gas piping systems **shall not** be used as part of a grounding electrode system (NFPA 70-2005, Article 250.52(7)(B)), but **shall** be bonded upstream from the equipment shut-off valve to the grounding electrode system as required by NFPA 70-2005, article 250.104 and NFPA 780-2004, section 4.14.1.3.

NOTE: In situations where metal piping systems (other than gas piping) may be required for use as part of a grounding electrode system, electrical continuity **shall** first be verified. See NFPA 70-2005, Article 250.68(B) for more details.

Figure 5-42, Figure 5-43, and Figure 5-44 show grounding options for integrated sites.

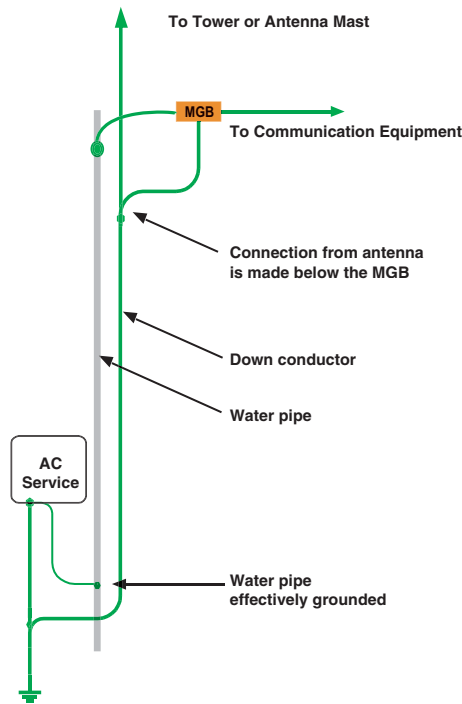

NOTES:

1. 35 mm² csa (#2 AWG) conductor for runs of 10 m (33 ft.) or less.
2. 95 mm² csa (#3/0 AWG) conductor for runs longer than 26 m (84 ft.)
3. See Table 5-3 on page 5-27 for other cable lengths and conductor sizing requirements.

FIGURE 5-42 SITE ON DIFFERENT FLOOR THAN AC SERVICE FEED, BUILDING STEEL NOT AVAILABLE

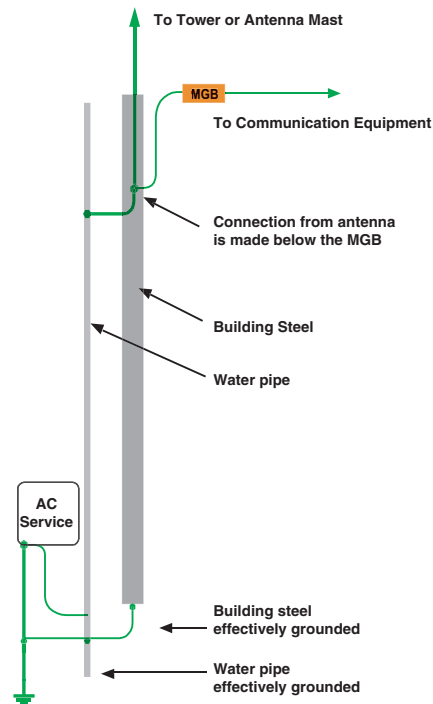

NOTES:

1. 35 mm² csa (#2 AWG) conductor for runs of 10 m (33 ft.) or less
2. 95 mm² csa (#3/0 AWG) conductor for runs longer than 26 m (84 ft.)
3. See Table 5-3 on page 5-27 for other cable lengths and conductor sizing requirements.

FIGURE 5-43 SITE ON DIFFERENT FLOOR THAN AC SERVICE FEED, BUILDING STEEL AVAILABLE

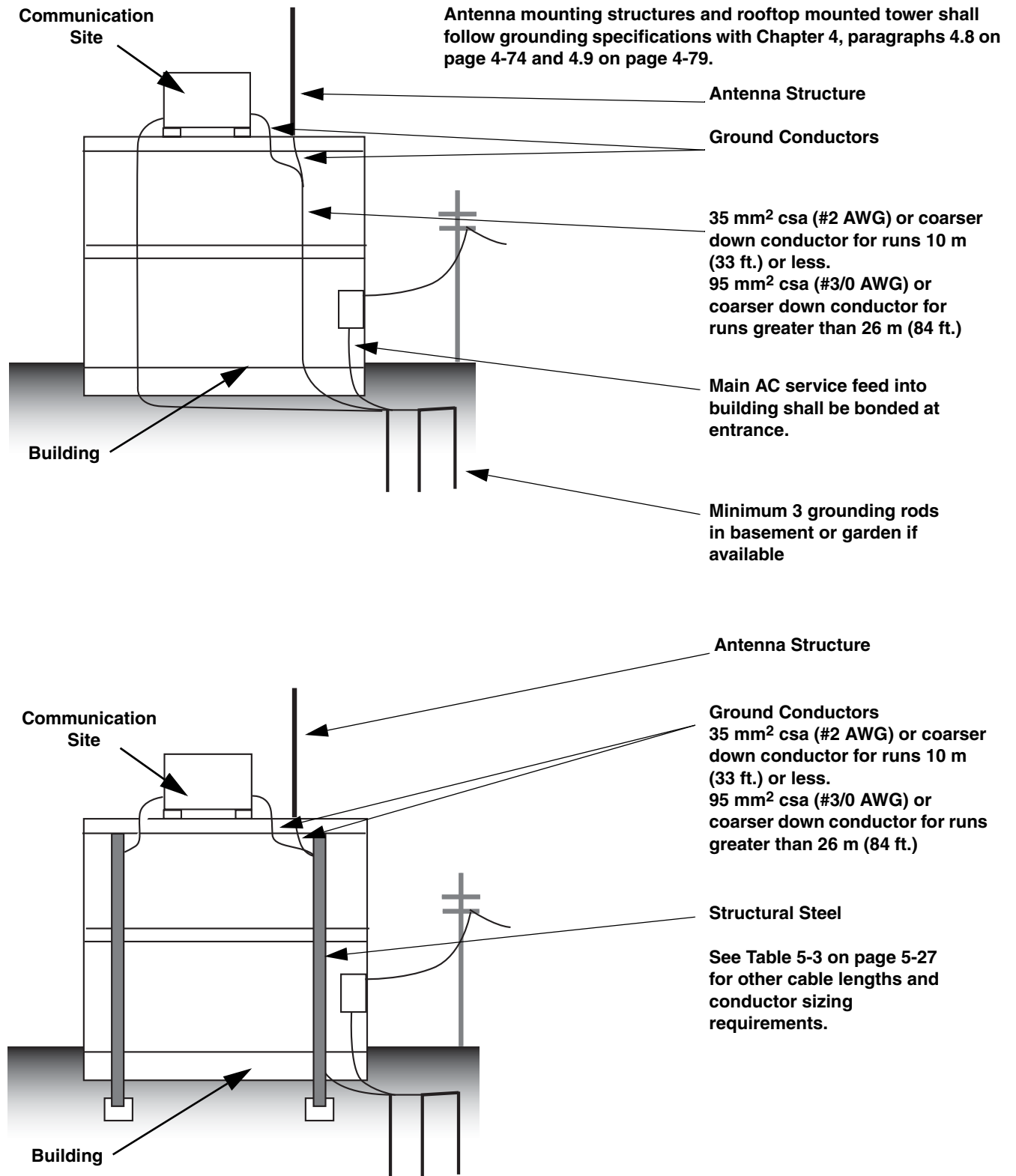

FIGURE 5-44 GROUNDING ROOFTOP INSTALLATIONS

THIS PAGE INTENTIONALLY LEFT BLANK.

POWER SOURCES

This chapter describes various types of power systems that are used for communications sites. It also specifies requirements for various types of power systems that are typically used at a communication site. The following topics are included:

- “Lockout/Tagout” on page 6-1
- “AC Power” on page 6-1
- “Power Quality” on page 6-11
- “Rectifier/DC Power Systems” on page 6-19
- “Uninterruptible Power Supplies” on page 6-24
- “Alternate Power Sources” on page 6-25
- “Battery Systems” on page 6-27
- “Standby Generator Systems” on page 6-35
- “Generator Output and Derating Considerations” on page 6-36

6.1 LOCKOUT/TAGOUT

On all power systems (AC or DC), a provision **shall** be present to lock out and tagout any circuit to help ensure the circuit is safe to work on. (See NFPA 70-2005 for additional information.)

6.2 AC POWER

All AC power systems **shall** be designed, installed and maintained in accordance with jurisdictional standards and regulations.

All site power loading **shall** be determined for initial equipment installation and future expansion. The determined loads at various locations throughout the site **shall** then be factored into the site electrical design.

Continuous load **shall not** exceed 80% of the electrical system, (wire, panel board, breakers, and service rating). Using this standard allows all participants in site design (electric power company, prefabricated shelter vendor, UPS vendor, generator vendor, etc.) to ensure that the power capacity supplied to the communications site is adequate.

Minimum acceptable service for US installations is typically 100 amps @ 120/240 VAC (or 120/208 VAC). A 200 amp (or larger) service may be required for existing/future loads or for additional circuit breaker positions. (Other service parameters may be applicable for nondomestic installations.)

Sizing of AC power loads is critical in calculating supply capacity. Typical power needs are:

- HVAC system (including redundant units). Most sites consisting of shelters will not be continuously occupied. In such case, the service personnel heat load need not be considered.
- Room lights and possible outdoor security lighting

NOTE: A standby generator may be required for continuity of service at sites where tower lighting is required to meet FAA requirements.

- Tower lighting. Some tower lighting systems may require additional power capacity (strobes, multiple fixtures, etc.).
- Number of dedicated circuits for major pieces of equipment, including isolated equipment
- Battery chargers
- Uninterruptible power supplies (UPSs)
- Equipment powered by rectifier systems (-48 VDC or similar)
- Utility receptacles. The number of utility receptacles required at a site is determined based on the size of the equipment room or shelter.
- The AC electrical power requirements of the communications room when all transmitters are simultaneously keyed **shall** be considered (see NFPA 70-2005, Article 220 and Article 310.15 for additional information).
- Planned future expansion
- Consideration of unusual maximum continuous loads (such as trunked system failsoft operation).

6.2.1 ELECTRICAL SERVICE

The power company usually provides the service to the meter in underground installations and to the weatherhead in overhead installations. All wiring after the meter typically is the responsibility of the customer. Primary metering (high voltage) may be an exception. It is important to note the demarcation point used by the power company serving the region where the site is being constructed. This location affects installation costs.

The following requirements **shall** be observed when specifying and installing electrical service to the site building:

- Work practices that help ensure safety **shall** be observed while performing all electrical work as required by (but not limited to) agencies such as OSHA, NFPA, NFPA70-2005, BOCA and local codes.
- Throughout the US, the local buried utility locator service **shall** be contacted before excavating. In other countries, the local utility **shall** be consulted to obtain buried utility location service.



WARNING

Failure to properly locate buried utilities can pose hazards to personnel. Failure to comply with regulations regarding buried utilities can result in penalties.

- Electrical installation work **shall** be carried out in accordance with the current edition of the NFPA 70-2005 and local building codes. Where required, only a qualified and licensed electrician **shall** be used for all electrical installations.
- Underground and above ground service entrance conductors **shall** be protected from physical damage (see NFPA 70-2005, Article 230.50 and 300.5 for additional information).
- The service entrance conductor may be a material other than copper if permitted by local codes.

- The site electric meter **shall** be located where it is visible and accessible to power company meter readers and **shall** comply with all applicable codes and/or power company requirements.
- Meter access by power company personnel should be considered when determining meter location (especially where a fence is involved). (See NFPA 70-2005, Article 100 and Article 230 for details regarding locations and service conductors.)

NOTE: The following refers to the Main Disconnect for the separately derived system feeding the equipment room. The Main Disconnect may not be located in the same building as the equipment (a meter farm at a tower site, for example). This makes the panel in the building with the equipment a sub-panel and not the main disconnect.

- At all sites, there is either or both a main service disconnect and a fused disconnect. A main service disconnect may be located at a meter location away from the building. A main disconnect located within the shelter, equipment room or area may be fed by a feeder circuit originating at a main service disconnect located in an electrical room in a different location in the building or even a separate building. Typically, the neutral and ground conductors are bonded in the main service disconnect. When the main service disconnect is located remotely from the equipment room or area, a separately derived system should be installed in the equipment room. (See NFPA 70-2005, Article 250.30 and 250.32 for additional information.)

One of the reasons for the separately derived system is to reestablish the neutral/ground bond, thereby improving the effectiveness of normal mode suppression.

NOTE: See Table 7-1 on page 7-7 and associated Chapter 7 figures for additional information regarding connections for separately derived systems.

- A fused disconnect **shall** always be installed before all other panels and equipment, including a generator transfer switch. (See NFPA 70-2005, Article 445.18 for additional information.)
- For a stand-alone equipment shelter, the main disconnect **shall** be located on the same wall as the coaxial cable entry port, the telephone entry point, and the MGB. If it is not possible to locate these components on the same wall, then these components **shall** be located on an adjacent wall as close together as possible. (See IEEE 1100-1999 Section 8.3.2.1.2 for additional information.)
- The main bonding jumper **shall** be installed between the neutral bus and the ground bus within the main service disconnect. This is to ensure an effective low-impedance neutral-to-ground bond connection. (See NFPA 70-2005, Article 250.24(B) for additional information.)
- Self-tapping or sheet metal type screws **shall not** be used for attaching ground or grounding conductors to any surface. (See NFPA 70-2005, Article 250.8 for additional information.)
- Paint, enamel, lacquer, or other nonconductive coatings **shall** be removed from threads and surface areas where connections are made. (See NFPA 70-2005, Article 250.12 for additional information.)

6.2.2 LOCATION OF NEUTRAL-GROUND BOND

It is strongly recommended for the proper performance of electronic equipment that the voltage between the neutral and ground conductors at the equipment be no more than 2V p-p (0.7 Vrms). Where the disconnecting means of the electrical service is remotely located to the site, the voltage developed between neutral and ground may cause equipment to malfunction, especially during a ground potential rise at the site. For the optimum performance of a Surge Protective Device (SPD) installed at the AC distribution panelboard, the Neutral-to-Ground bond must be near the SPD in order for the SPD to effectively redirect unwanted energies on the AC power cables safely to the site grounding (earthing) electrode system. Due to the physical separation between the remote service entry disconnecting means and the site disconnecting means, a steady state ground loop current could flow on the equipment grounding conductor bonding the two ground fields.

An approach for eliminating the steady state ground loop current and lowering the voltage between the Neutral and Ground conductors is to bond the Neutral-to-Ground at the remote service entry disconnecting means, and at the communications site disconnecting means as allowed by NFPA 70-2005, Article 250.32(B)(2). In order to accomplish this, the equipment-grounding conductor between the remote disconnecting means and the site disconnecting means **shall** be disconnected at both ends and removed.

Neutral-ground bonding requirements as allowed by NFPA 70-2005, Article 250.32 include:

- The AC equipment grounding (ACEG) conductor **shall not** be run between the remote disconnecting means and the shelter's disconnect.
- There **shall** be no other metallic continuity established between the remote disconnecting means and the site. Examples of continuity that is not permitted between the remote disconnecting means and the site could include metallic conduit and the data/ telecommunications metallic shields installed between the remote electrical service area and the site.
- Ground fault protection **shall not** be installed on the common AC service of the electrical disconnect

NFPA 70-2005, Article 250.32(B)(2) allows the bonding of the neutral and ground conductors at the separate building or structure and also eliminates the creation of parallel paths for normal neutral current on grounding conductors, metal raceways, metal piping, and other metal structures. In previous editions of the Code, the grounding electrode conductor and equipment-grounding conductors were permitted to be connected to the grounded conductor at a separate building or structure. This multiple-location grounding arrangement could provide parallel paths for neutral current along the equipment grounding conductors of the electrical system, metallic shields of cables, metallic structures that are continuous between, buildings, and along other continuous metallic piping and mechanical systems as well. Connection of the grounded conductor to a grounding electrode system at a separate building or structure is permitted only if these parallel paths are not created and if there is no common ground-fault protection of equipment provided at the service where the feeder or branch circuit originates. See Figure 6-1 on page 6-5.

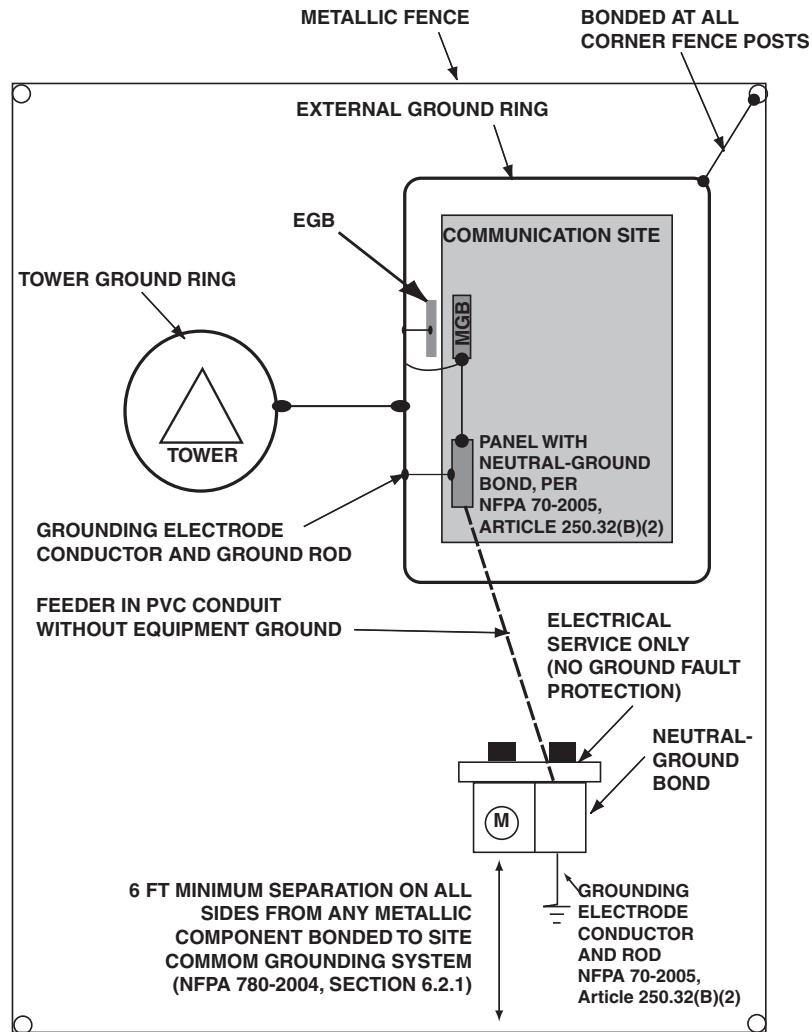

FIGURE 6-1 REESTABLISHING THE NEUTRAL-GROUND BOND AT THE COMMUNICATION SITE

6.2.3 SEPARATELY DERIVED SYSTEMS USING TRANSFORMERS

Communications site AC power can also be supplied by a transformer (also known as an isolation, step-down, or step-up transformer). Separately derived transformers are typically used to step down three-phase 277/480 VAC service to standard commercial 120/208 VAC service.

To improve the effectiveness of line-to-neutral (normal mode) surge suppression, the transformer creates a separately derived system where the neutral and ground conductors **shall** be bonded together within the transformer or within the first disconnect after the transformer and bonded to the building's common grounding electrode system. (see NFPA 70-2005, Article 250.30 for additional information.) See "Separately Derived AC Systems" on page 5-42.

6.2.4 INTERIOR ELECTRIC

The following requirements **shall** be observed when specifying and installing interior electrical service:

- All panel boards and switch boards **shall** display signage and placarding per NFPA 70-2005, Article 110.22 and applicable local codes.
- When designing a site floor plan with electrical panels utilizing voltages of 600 VAC or less, a clearance of 914 mm (36 in.) **shall** be provided in front of any electrical panel in accordance with NFPA 70-2005, Article 110.26.
- A working space equal to the width of the equipment or 762 mm (30 in.), whichever is greater, **shall** be provided in accordance with NFPA 70-2005, Article 110.26.
- Additional clearance **shall** be provided based on the voltage present in electrical panel exceeding 120/240 VAC. See Figure 6-2.

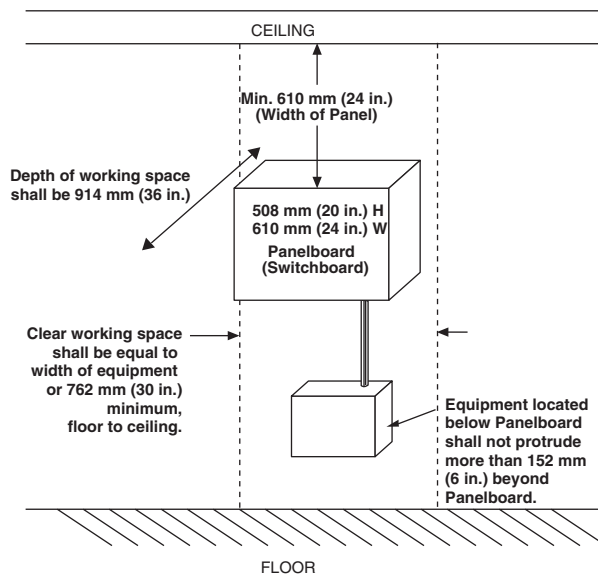

FIGURE 6-2 ELECTRICAL PANEL CLEARANCES

- Equipment that operates on 48 VDC, or 600 VAC require different clearance. Clearance **shall** be in accordance with NFPA 70-2005, Article 110.26, or applicable local codes.
- All internal wiring **shall** be copper. (see NFPA 70-2005, Article 110.5 for additional information).
- Power panels, load centers, and breaker boxes **shall** be identified using distinctive placarding/labeling identifying their purpose and location of the main service disconnect. (See NFPA 70-2005, Article 110.22 and Figure 8-3 for additional information.)
- Wire, terminals and lugs **shall** be of similar or compatible metals (NFPA 70-2005, Article 110.14).

6.2.5 POWER PANELS

The following requirements **shall** be observed when specifying and installing interior electrical service:

- Each main distribution panel **shall** have its own main overcurrent protective device (circuit breaker/fuse). (See NFPA 70-2005, Article 408.36(B) for additional information.)
- All interior panelboards and junction boxes **shall** be NEMA Type 1 general purpose for indoor application.
- More than one distribution panel may be necessary for large single equipment rooms in order to support the number of required branch circuits. If more than one distribution panel is utilized then all panels **should** be fed from the same separately derived system. This is done to prevent ground loops from multiple neutral ground bonds at the transformer. (See IEEE STD 1100-1999 for additional information.)
- Power panelboards **shall** be bonded to the interior single point grounding window system. See “Internal Grounding (Earthing)” on page 5-1 for the requirements on the proper methods of grounding and bonding equipment.
- When using a UPS, two distinct power panels **shall** be utilized as follows:
 - Equipment Power Panel (UPS Panelboard)
This panel provides power for the communications equipment and all associated electrically powered items. It is fed from the UPS.
 - Utility Power Panel
This panel provides power for circuits and loads other than the communications equipment. This panel feeds the UPS and non-UPS site electrical equipment such as lighting, HVAC and wall mounted receptacles, etc.

6.2.5.1 OUTDOOR ELECTRICAL (BRANCH CIRCUITS)

This paragraph provides requirements for branch circuits that exit the equipment shelter for use with outdoor equipment.

- All outdoor electrical equipment **shall** be protected from the environment and sealed from the elements.
- All outdoor receptacles **shall** be GFCI-type receptacles or breakers. (See NFPA 70-2005, Article 210.8 for additional information.)
- Non-flexible conduit **shall** be used for all exterior circuit branches. An exception are feeds to vibrating equipment such as air conditioning units, which may use liquid-tight flexible sealed conduit.
- All exterior wall penetrations through which conduit passes **shall** be sealed.
- Exterior panelboards, receptacles and switches **shall** be housed in NEMA Type 3 or Type 3R housing.

6.2.6 CIRCUIT PROTECTION

The following requirements **shall** be observed when specifying and installing circuit protection devices:

NOTE: Locked-rotor starting current **shall** be considered when specifying breaker values for such items as the air conditioner compressor motors and fans. Power amplifiers keyed to full power can also pose unusual start-up loads. Such loads may also affect the type of breaker used for the circuit.

- A means of removing power from a given circuit or load without disrupting other equipment **shall** be provided.
- Circuits for communication equipment **shall** be 15 A minimum. 20 A circuits are recommended for each branch circuit feeding communications equipment and associated equipment.
- Branch circuit breakers for all other equipment such as lighting, heating and air conditioning **shall** be rated per manufacturer specifications as per code.
- Breakers and their associated receptacles **shall** be uniquely labeled and correlated to the respective power panel unless required differently for specific equipment. (See NFPA 70-2005, Article 408.4 for additional information.)
- Panel schedule **shall** be filled out and kept up to date. (See NFPA 70-2005, Article 408.4 and Figure 6-3 for additional information).



FIGURE 6-3 PANEL SCHEDULE

- Circuit breakers **shall** be sized to protect the conductor attached to them, not the load on the circuit. (See NFPA 70-2005, Article 240.4 for additional information.)

6.2.7 CONDUCTORS

The following requirements **shall** be observed when specifying and installing conductors:

- Aluminum conductors **shall not** be used.
- All branch conductors **shall** have an allowable ampacity equal to or greater than the non-continuous load plus 125% of the continuous load. (See NFPA 70-2005, Article 210.19(A)(1) for additional information.)
- It is recommended that a conductor of 8 mm² csa (#12 AWG) minimum be used in the equipment panel for circuit branches.

NOTE: On 3-phase branch circuits it is very important that the neutral conductor be sized appropriately for overcurrent that may be induced upon the neutral by a possible load imbalance.

- The neutral conductor **shall** be equivalent in size to its associated load carrying conductors. In special circumstances (such as highly reactive loads that may generate harmonics), the neutral should be increased to up to 175% of its original size. (See NFPA 70-2005, Article 220.61 for additional information.)
- All single phase circuits **shall** be 3-wire.

6.2.8 CONDUIT

The following requirements **shall** be observed when specifying and installing conduit:

- All interior surface-mounted building wiring **shall** be run in rigid electrical metallic tubing (EMT) or electrical raceways. (See NFPA 70-2005, Article 358 and IEEE STD 1100-1999, *Powering and Grounding Electronic Equipment* paragraph 8.4.8.2. for additional information.)
- The conduit **shall not** be used as the AC equipment grounding (ACEG) conductor. An individual circuit equipment grounding conductor **shall** be installed in each conduit exiting the panelboard and be connected electrically. The arrangement of grounding connections **shall** be such that the disconnection or removal of a receptacle, fixture, or other device fed from the box will not interfere with (or interrupt) the equipment grounding conductor continuity.
- The conduit **shall** be securely fastened every 3 m (10 ft.) and within 914 mm (3 ft.) of any receptacle box, junction box, panel board or any termination of the conduit. (See NFPA 70-2005, Article 358.30 for additional information.)
- For tenant improvements, applicable local codes **shall** be observed.
- Conduit runs may be mounted to the cable tray support structure. These cable trays (along with ceiling attachments) **shall** be designed and installed to support an EMT distribution system, including all hardware-related fittings and boxes, as well as the distributed load in the tray. (See NFPA 70-2005, Article 314.23 for additional information.)
- Conduit **shall not** be mounted to cable trays in isolated ground zones.
- Flexible metal conduit may be used to carry a circuit branch conductor to vibrating equipment, and suspended lighting fixtures. (See NFPA 70-2005, Article 348 for additional information.)
- Liquid-tight flexible metal conduit **shall** be used where additional protection from liquids, vapors or solids is required. (See NFPA 70-2005, Article 350 for additional information.)

6.2.9 HARDWIRING OF EQUIPMENT AND DEDICATED RECEPTACLES

Extension cords **shall not** be used to power permanent communication equipment at a site.

When an open equipment rack is used, hardwiring of power is not always possible. Mounting a dedicated simplex receptacle or receptacle assembly on the rack may be the most convenient method of supplying power, especially if multiple pieces of equipment are mounted on the rack. This is also a convenient way to install personal protection Type 3 SPD devices to the equipment.

These receptacle assemblies can be pre-manufactured and mounted to the top face of an equipment rack. Mounting can also use a fabricated power pole mounted between racks.

6.2.10 RECEPTACLES

The following requirements **shall** be observed when specifying and installing receptacles for powering communications equipment:

- To ensure reliability, each major piece of equipment and each half of a redundant power supply **shall** have its own dedicated individual branch circuit and dedicated simplex receptacle.
- Equipment racks may require special attention to support the dedicated simplex receptacle scheme. To comply with the dedicated simplex receptacle concept, receptacles have to be located on or very near the rack of equipment. One method is to use a specialized Multi-Receptacle AC panel with dedicated circuits that **shall** be mounted on the equipment rack or enclosure. (These Multi-Receptacle AC panels **shall** be hard wired to the breaker panel, and each simplex receptacle **shall** use an individual branch circuit.)
- To eliminate the possibility of two pieces of equipment turning on at the same time and momentarily exceeding the amperage capacity of the circuit, simplex receptacles should be used instead of duplex receptacles.

NOTE: Duplex receptacles may be fed from two separate circuits only if the connecting tabs on the receptacles are removed. The neutral **shall not** be shared by two receptacles. In this case, only one equipment grounding conductor is required for the two circuits.

- Receptacle ratings should be determined by conductor and circuit breaker current ratings. Consider future expansions.
- Isolated ground receptacles should not be used unless recommended by the equipment manufacturer (IEEE STD 1100-1999). Isolated ground receptacles are not recommended for use at operator positions. See “Grounding (Earthing) for Dispatch Centers and Network Operator Positions” on page 5-62.
- All 120 VAC receptacles **shall** have three conductors: phase, neutral, and ground (IEEE STD 1100-1999).
- Power cord plugs **shall** be supported with strain reliefs adequate to prevent accidental disconnection where applicable. Twist-lock plugs **shall not** be used in lieu of strain relief.
- All communications equipment receptacles **shall** have the electrical box or cover plate permanently marked with the service panel and appropriate circuit identification. This identification **shall** be readily visible without requiring removal of the plug.

- Receptacles meant to serve loads other than communication equipment **shall** be fed from the main distribution panel board and not from the equipment panel or the UPS. See “Power Quality” on page 6-11 for additional information.
- Outlet boxes or enclosures **shall** be securely mounted (NFPA 70-2005, Article 300.11 and 314.23). Cable ties **shall not** be used as a method of securing outlet boxes or receptacles.

6.2.11 RECEPTACLE STRIPS

- Extension blocks or receptacle strips **shall not** be mounted on the floor. Damage can result from foot traffic or water, and water seepage or fire sprinkler activation may pose an electrocution hazard to personnel.
- Receptacle strips are intended to provide AC power to low-power equipment where several line-powered items are closely collocated (such as an operator's position). In general, the following considerations need to be observed in selecting and installing receptacle strips:
 - If powering multiple similar devices from a receptacle strip, ensure that failure of the strip does not affect system availability. For example, do not plug all modems into the same receptacle strip.
 - Receptacle strips are limited to specific applications only where a receptacle strip is suitable for use. In all cases, receptacle strips **shall** be UL listed and of metal construction.
 - Receptacle strips **shall** be easily mountable without requiring disassembly.
 - AC power receptacle strips **shall** have a 3-prong power cord when used for permanent installations.
 - Receptacle strip **shall** be securely mounted to the supporting structure using intended bolt mounting and **shall not** be secured by being tie-wrapped.
 - Receptacle strips **shall not** include ON/OFF switches unless the ON/OFF switch is covered to help prevent the switches from being inadvertently switched off.
 - Consumer-grade surge-protected or locally fused receptacle strips **shall not** be used. Proper equipment setup and facility electrical design should accommodate these requirements.
 - No more than one receptacle strip **shall** be connected to the same branch circuit.
 - Redundant equipment pairs **shall not** be connected to the same receptacle strip.
 - Items considered individually critical (where no backup can easily be implemented) **shall not** be powered from a receptacle strip.
 - If multiple receptacle strips are used, they **shall** be plugged into dedicated simplex receptacles on individual branch circuits.

6.3 POWER QUALITY

Power quality is defined as “the concept of powering and grounding electronic equipment in a manner that is suitable to the operation of that equipment and compatible with the premise wiring system and other connected equipment” (IEEE STD 1100-1999 and IEEE STD 1159-R2001). In order to operate reliably, electronic equipment **shall** be supplied with quality AC power.

The objective of Motorola site standards and guidelines is to establish benchmarks for designing optimum equipment operating environments. Providing quality power to electronic equipment is a key to system availability and system reliability.

See “Glossary” on page 1-11 for definitions of terms relating to power quality.

6.3.1 FUNDAMENTALS OF POWER QUALITY

This paragraph presents a brief introduction to power quality. See IEEE STD 519, IEEE STD 1100 and IEEE STD 1159 for additional information. The requirements and recommendations presented in this paragraph take into consideration established industry codes and standards for achieving operational environments that are suitable for electronic equipment. The American National Standards Institute (ANSI), British Standards Institution (BS), Institute of Electrical and Electronics Engineers (IEEE), International Electrotechnical Commission (IEC), and the Telecommunications Industry Association (TIA) have developed steps necessary for establishing a foundation to support the operation of electronic equipment.

The quality of power supplied to electronic equipment is influenced by, but not limited to, the following:

- Equipment load requirements
- Grounding (earthing) of the facility
- Sufficient delivery of power
- Interaction between connected loads
- Internal and external wiring
- Placement of the electronic equipment within the facilities

Many of the areas of concern affecting power quality are also addressed as minimum safety requirements specified by NFPA 70-2005 or other electrical codes in effect by the local authority having jurisdiction (AHJ). However, these minimum safety requirements are typically not sufficient to support the operation of electronic equipment.

6.3.2 COMMON CAUSES OF POWER QUALITY PROBLEMS

Table 6-1 summarizes some of the common causes of power quality problems. (See IEEE STD 1159-R2001 for additional information.)

TABLE 6-1 COMMON CAUSES OF POWER QUALITY PROBLEMS

Problem	Common Cause
Frequency Deviation	<ul style="list-style-type: none"> • Faults on the bulk power transmission system • Large block of load being disconnected • Large source of generation going off-line • Generator system faults
Voltage Sags (or dips) See Figure 6-5 on page 6-14 for example.	<ul style="list-style-type: none"> • System faults • Switching of heavy loads • Starting of large motors • Large load changes • Adverse weather conditions
Voltage Swells See Figure 6-5 on page 6-14 for examples.	<ul style="list-style-type: none"> • System faults • Single line-to-ground fault on the system resulting in a temporary voltage rise on the non-faulted phases • Switching off a large load • Switching on a large capacitor bank
Transients See Figure 6-6 on page 6-14 for example.	<ul style="list-style-type: none"> • Adverse weather conditions • Lightning • Load switching • Fault clearing • Capacitor discharge • Utility switching
Total Harmonic Distortion (> 5%) See Figure 6-7 and Figure 6-8 on page 6-14 for examples.	<ul style="list-style-type: none"> • Normal operation of nonlinear devices • Noise generating loads • Poor grounding (earthing) • Synthesized sine wave from a UPS or power conditioner

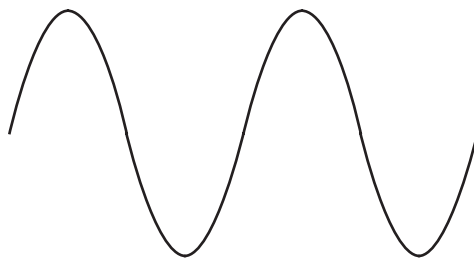
**FIGURE 6-4** NORMAL SINUSOIDAL WAVEFORM

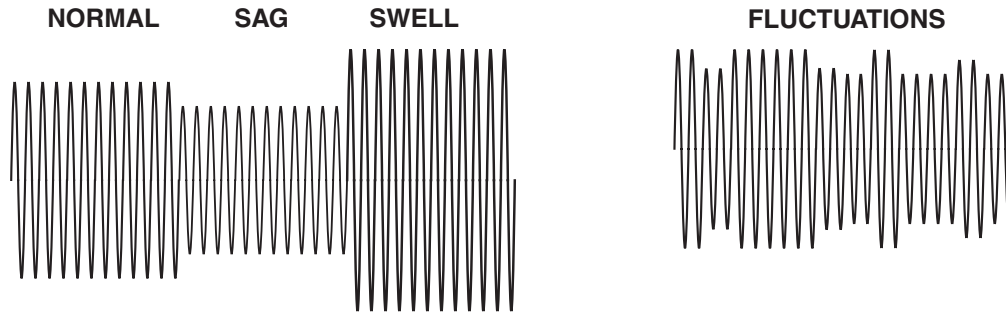

FIGURE 6-5 VOLTAGE SAGS, SWELLS, AND FLUCTUATIONS

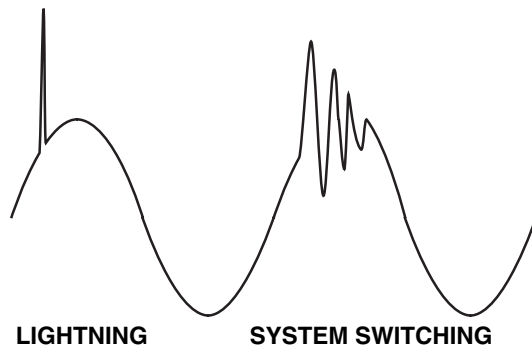

FIGURE 6-6 TYPICAL TRANSIENT VOLTAGES

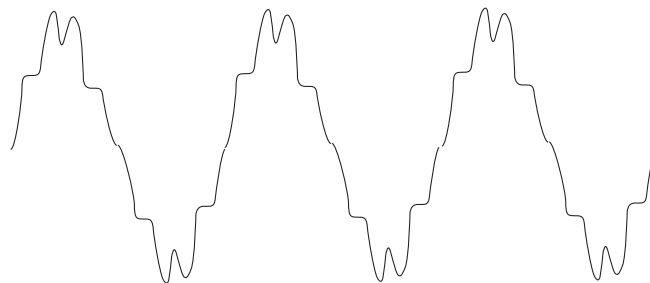

FIGURE 6-7 HARMONIC DISTORTION EXAMPLE

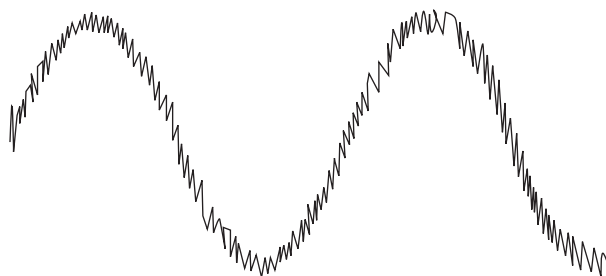

FIGURE 6-8 NOISE EXAMPLE

6.3.3 COMMON EFFECTS OF POWER QUALITY PROBLEMS

The following table summarizes the common effects of power quality problems on connected equipment:

TABLE 6-2 COMMON EFFECTS OF POWER QUALITY PROBLEMS

Problem	Common Effect
Frequency Deviation	<ul style="list-style-type: none"> • Writing errors in any electronic writing device • Incorrect clock timing
Voltage Sags (or dips)	<ul style="list-style-type: none"> • Equipment shutdown • Power supply interruptions • CPU lock up • Data errors
Voltage Swells	<ul style="list-style-type: none"> • Microprocessor failure • Progressive damage to power supplies
Transients	<ul style="list-style-type: none"> • Damage to microprocessors • Data errors or loss • Lock ups • Catastrophic failure of electronic equipment
Total Harmonic Distortion (> 5%)	<ul style="list-style-type: none"> • Failure of microprocessor controlled equipment • Overheating of electrical system components • Decreased life expectancy of electrical system transformers • Circuit breakers tripping

6.3.4 COMMON POWER QUALITY PROBLEM REMEDIES

The table below generalizes some common remedies of power quality problems. A power quality engineer may be required to help resolve power quality problems.

TABLE 6-3 COMMON POWER QUALITY PROBLEM REMEDIES

Problem	Common Remedy
Frequency Deviation ¹	<ul style="list-style-type: none"> • Report problem to the utility if the frequency deviation is measured on the AC utility • Make corrective repairs to onsite generator if the frequency deviation is measured on the generator
Voltage Sags (or dips)	<ul style="list-style-type: none"> • Corrective wiring • Relocation of critical loads • Power conditioners • UPS systems
Voltage Swells	<ul style="list-style-type: none"> • Surge Protective Devices (SPD) • Power conditioners • UPS systems
Transients	<ul style="list-style-type: none"> • Surge Protective Devices • Filters
Total Harmonic Distortion (> 5%) ²	<ul style="list-style-type: none"> • Isolating the noise • Proper grounding • Power conditioners • Moving loads away from noise generators • UPS with a true sinusoidal waveform output (typically found with IGBT (insulated gate bipolar transistor) rectifier technology)

1. Frequency variations are much more likely to occur when equipment is powered by an onsite generator, versus the AC utility (IEEE STD 1159-R2001).
2. See IEEE STD 519, Recommended Practices and Requirements for Harmonic Control in Electric Power Systems for additional information.

6.3.5 POWER QUALITY TESTING THRESHOLDS

The table below lists the recommended thresholds when testing AC power quality in most single-phase and three-phase configurations (IEEE STD 1100-1999). The actual thresholds used should be based on the installation requirements of the connected equipment, as the connected equipment may have more stringent requirements. See IEEE STD 1159-R2001 for additional information.

TABLE 6-4 MINIMUM RECOMMENDED AC POWER QUALITY TESTING THRESHOLDS

Category	Suggested Not-to-Exceed Thresholds
Phase Voltage Testing Thresholds	
Frequency Deviation	± 0.5 Hz
High Frequency Noise	Approximately 1% of the phase-neutral voltage
Voltage Sags	-10% of nominal supply voltage (108 V for a 120 VAC circuit)
Voltage Swells	+5% of nominal supply voltage (126 V for a 120 VAC circuit)
Transients	Approximately 100 V over the nominal phase-neutral voltage
Distortion	5% Total Harmonic Distortion (THD) – the voltage distortion level at which loads may be affected
Neutral-ground Voltage Testing Thresholds	
High Frequency Noise	2-3 V_{peak}
Voltage Swells	1% to 2.5% of nominal phase-neutral voltage

6.3.6 STEPS TO DEVELOPING A POWER QUALITY PLAN

Prior to deployment of electronic equipment, a power quality action plan should be established. To help determine necessary corrective action, the equipment's operating norms should be reviewed according to the manufacturers' stated requirements for optimal performance. Next, a complete assessment of the facility's current electrical environment should be conducted and compared to the requirements for the equipment. Load requirements, grounding, bonding, isolation and protection requirements should be considered.

To help maintain an optimal electrical environment, a power quality monitoring plan should be in place. The power quality monitoring plan should require regular review of the performance of the site's operating norms. This should include regular monitoring and recording of the site's power system, its connected loads, failures and interruptions. The objective of the power quality monitoring program is to identify problems and take corrective actions before incidental interference results in a wide area failure.

6.3.7 GENERAL RECOMMENDATIONS TO HELP PROMOTE GOOD POWER QUALITY

The following list presents some general recommendations to help promote good power quality. See IEEE STD 1100-1999, *Recommended Practice for Powering and Grounding Electronic Equipment*.

- Use a UPS or other source of backup power on critical loads.
- Use a UPS system that provides a true sinusoidal wave output to help maintain a total harmonic distortion (THD) below 5% (typically found in a UPS that uses IGBT rectifier technology).
- Isolate critical loads and electronic equipment from noisy or inductive loads (e.g. Motor driven cleaning equipment, space heaters, fans, copiers and printers).
- Separate critical loads/ electronic equipment and other loads onto different panelboards (IEEE STD 1100-1999).
- Install an insulated grounding conductor on receptacles that feed critical loads or electronic equipment, versus relying on the metallic conduit (IEEE STD 1100-1999, section 8.5.3).
- Match circuit availability to the load requirements (e.g., 15 amp circuits are not powering equipment that requires a 20 amp circuit).
- Maintain minimum separation between AC power conductors and other communications cabling.
- Restrict access to power control panels and mark electrical receptacles according to use (e.g., HVAC controls, electrical panels and switch boards, circuits for critical loads or other uses).
- Follow the recommendations/requirements of Chapter 7, “Surge Protective Devices.”
- Follow the recommendations/requirements of Chapter 6, “Power Sources.”
- Follow the recommendations/requirements of Chapter 5, “Internal Grounding (Earthing).”
- Follow the recommendations/requirements of Chapter 4, “External Grounding (Earthing).”
- Follow the recommendations/requirements of Appendix B, Protecting Against Electrostatic Discharge in Equipment Rooms and Dispatch Centers.

6.3.8 POWER QUALITY TESTING LOCATIONS

When monitoring a site that is serving several loads, it may be advantageous to initially install the power quality monitor at the power panel feeding the system to obtain an overall profile of the voltage. The power quality monitor can then be relocated to the circuits serving individual loads, or loads that are experiencing malfunctions and failures. Comparison of disturbance data can help locate the source of the disturbances and determine how to most effectively remedy the problem. (IEEE STD 1100-1999, section 6.4.2.5.)

Motorola recommends the following locations for testing power quality:

- To assess the power quality delivered to an individual piece of electronic equipment, test at the equipment's receptacle, especially if the equipment is exhibiting malfunctions and/or failures.
- To assess the quality of output power from a power conditioner or UPS system, test at the power conditioner or UPS power panelboard (or as close as practical).
- To assess the power quality of secondary distribution, test on the secondary of the equipment room transformer.
- To assess the overall power quality delivered to a facility, test at the facility's main electrical panel.

6.3.9 POWER QUALITY TESTING DURATION

The monitoring period is a direct function of the monitoring objective. Usually the monitoring period attempts to capture a complete power period, an interval in which the power usage pattern begins to repeat itself. For example, an industrial plant may repeat its power usage pattern each day, or each shift. Depending on the monitoring objective, it may be necessary to monitor as little as one shift. (IEEE STD 1159-R2001, section 7.5.1)

It is generally recommended that the minimum monitoring period include at least one full work cycle, normally seven or eight days. Longer monitoring periods are often needed to record disturbances that occur on a random or seasonal basis. (IEEE STD 1100-1999, section 6.4.2.5.)

6.4 RECTIFIER/DC POWER SYSTEMS

This section provides guidelines and specifies requirements for selecting and installing site rectifier/DC power system systems and components. Note that although specific recommendations are stated here, actual equipment specifications are largely determined by factors peculiar to the installation being performed. These stipulations are noted throughout the section.

6.4.1 RECTIFIER SYSTEM REQUIREMENTS

6.4.1.1 ACCEPTABLE RECTIFIER TYPES

Two general types of rectifiers are acceptable for powering communications equipment. The types are:

- Controlled Ferroresonant Rectifier

A controlled ferroresonant rectifier exhibits an exceptionally good Mean Time Between Failure (MTBF), and typically provides an output exceeding 110% - 120% of its rating for the life of the rectifier. Forced load sharing is an essential feature of these rectifiers. In a multiple rectifier system, it prevents a single rectifier's output from drifting down and becoming inefficient.

Both a potential drawback as well as benefit of this rectifier is its transformer. In an area prone to excessive AC transients, a controlled ferroresonant rectifier will continue to function satisfactorily. However, the transformer is large and heavy. Suitability of this rectifier type will be based on balancing these criteria.

Although a ferroresonant supply is simple, low cost, and handles high current, it cannot handle AC line frequency shifts, particularly on the low side. An applied low line frequency (even 59 Hz) causes the ferroresonant supply to draw high current over excessive ON cycles. This overheats the transformer and causes close to short-circuit conditions within the tuned reactive circuit. A backup generator with a defective speed governor is a typical source of this trouble.

- **Switchmode Rectifier**

A switchmode rectifier offers a size and weight advantage over ferroresonant rectifiers in that its transformer is smaller and lighter than controlled ferroresonant rectifiers. This type of rectifier will provides an output of 105% of its rating for the life of the rectifier.

The drawback to the switchmode rectifier is that it does not have the large transformer to absorb transient surge voltages. These transient surges can shorten the life of the switchmode rectifier. In areas prone to significant transient voltages, controlled ferroresonant rectifiers may be a better choice. The lower MTBF of a switchmode rectifier can be offset by its ease of replacement. Also, the inefficiency at low output levels of these rectifiers is not nearly as severe as that of the controlled ferroresonant rectifier; therefore, forced load sharing is not required. A switch mode rectifier that is well-filtered to prevent radiated RFI and superimposed noise on the DC output circuit should be selected.

Silicon Controlled Rectifier (SCR)-based rectifier systems are not acceptable for powering Motorola systems, due to tendencies of SCRs to allow AC transients to propagate to the DC side.

6.4.1.2 REDUNDANCY

An n+1 redundancy setup is recommended, at a minimum, for the rectifier system. An n+1 redundant scheme employs one rectifier more than is required to power the system. In many cases, the redundant rectifier also provides for recharging of the batteries after a power outage.

6.4.1.3 RECTIFIER SIZING

In general, the power system selected should be appropriately sized based on the installation being performed.

- In systems requiring 1200 A or less, 2.5 kW (50A@-48V; 100A@24V) switchmode modular rectifiers (or equivalent) are recommended.
- In systems requiring more than 1200 A, modular rectifiers as described above are not typically recommended. This is based on the following:

An n+1 redundancy using low capacity rectifiers may not provide sufficient reserve capacity to fully recharge discharged batteries within 24 hours. An n+2 or n+3 design may be necessary to handle recharge. However, this will affect overall system cost.

Higher-output systems based on higher-current rectifiers have a theoretically higher MTBF. A -48 V, 1000 A non-redundant system using 50 A rectifiers will contain 20 modular switchmode 100 A rectifiers. The same system using 200 A controlled ferroresonant rectifiers will contain only five 200 A rectifiers. The 200 A rectifier system has 25% as many potential points of failure as the 50 A system.

6.4.2 DC DISTRIBUTION

The power board or DC power distribution center is the infrastructure around which the power system is built. A power board can be divided into two components: the meter/alarm and the control section/distribution section. The distribution section of the power system can be reconfigured, expanded, and modified in many ways, however, when the meter, alarm, and control section is at capacity, any further expansion requires the replacement of the power board. Over sizing of the power board is relatively inexpensive because most of the over sizing consists of copper bus bars.

6.4.3 LOW VOLTAGE DISCONNECT

DC systems, with battery back-up, **shall** be equipped with a Low Voltage Load Disconnect (LVLD). A Low Voltage Battery Disconnect (LVBD) **shall not** be substituted for the LVLD. A battery system is considered to be fully discharged when the voltage reaches 1.75 VPC (volts per cell). In a 48 volt system (24 cells) the battery plant is fully discharged when the voltage reaches 42 volts (1.75x24). Battery damage begins to occur when the voltage drops below this point.

Continuing to operate the system beyond this point with the intent of providing service to the end user at the expense of damaging or destroying the batteries may not be possible. Internal power supplies that provide logic and memory voltages (typically +12V, -12V, and +5V) are designed to provide regulated power throughout a specific input voltage range. This range is typically within a few volts of the batteries operating range. When the input voltage drops below the specified range, the output voltage of the internal power supplies will no longer be within the specified limits. In many cases, the internal power system will shut down. If the internal power supplies do not shut down, damage or erratic operation may occur. Although a low voltage disconnect does protect the battery plant, it also is required to protect the load equipment.

6.4.4 OVERCURRENT PROTECTION

Because fuses may not always be available, appropriate circuit breakers are recommended.

Overcurrent protection should be a minimum of 50% larger than the **anticipated** load for the circuit. In-rush currents (the current draw when a device is first powered on) **shall** also be considered when sizing circuit protection. Overcurrent protection **shall not** exceed the ampacity rating of the conductors.

6.4.5 POWER CABLING CAPACITY



WARNING

UL-listed General Use or Battery cable shall be used.

The power cables that supply DC power to site equipment **shall** be sized based on their anticipated load requirements and current carrying capacity (referred to as “ampacity”). Ampacity is determined by the short-term amperage the conductor can carry before generating sufficient heat to degrade the insulation. Ampacity is determined by the following factors:

- ambient temperature
- insulation type
- heat dissipating characteristics of the cable transport

A conductor has a higher ampacity in free air than one that is enclosed in conduit because the conduit retains the heat. In certain electrical codes, a raceway is an enclosed duct that the cables are run through. As such, the ampacity rating of DC cable in a raceway is lower than that installed on the cable tray.

Independent of short-term ampacity, allowable voltage drop must also be considered when sizing power cables for DC systems. In many cases, this requires the DC power cables to be larger than the cable required for an AC system.

6.4.6 FLOOR AND CEILING RUNS, PLENUM GRADE AND RISERS CABLING



WARNING

Non-plenum rated power cabling shall not be installed within plenums. Failure to use plenum-rated cables in these areas can result in generation of toxic fumes in the event of a fire.

NOTE: Feasibility and methods of wiring within plenums and risers **shall** conform with jurisdictional codes.

The following requirements specify installation practices that help, should a fire occur, minimize smoke and products of combustion from electrical wiring in areas that handle environmental air. A plenum is defined as a compartment or chamber to which one or more air ducts are connected and that forms part of the air distribution system. See NFPA 70-2005, Article 100 for additional information.

- Wiring systems of any type **shall not** be installed in ducts used to transport dust, loose stock, or flammable vapors (NFPA 70-2005, Article 300.22(A)).
- Wiring systems of any type **shall not** be installed in any duct, or shaft containing only such ducts, used for vapor removal (NFPA 70-2005, Article 300.22(A)).
- Wiring systems may be installed in ducts specifically constructed to transport environmental air only when such wiring consists exclusively of the following. See NFPA 70-2005, Article 300.22(B) for additional information:
 - Type MI (mineral insulated) cable
 - Type MC (metal-clad) cable employing a smooth or corrugated impervious metal sheath without an overall nonmetallic covering

- Type CMP (communications plenum cable), electrical metallic tubing, flexible metal tubing, intermediate metal conduit, or rigid metal conduit. Flexible metal conduit and liquid-tight flexible metal conduit **shall** only be permitted in lengths not exceeding 1.2 m (4 ft.), to connect physically adjustable equipment and devices permitted to be in the ducts. See NFPA 70-2005, Article 300.22(B) for additional information.
- Wiring installed in other spaces used for environmental air, such as the area above a suspended ceiling or as otherwise defined in NFPA 70-2005, Article 300.22(C), **shall** be installed in accordance with NFPA 70-2005, Article 300.22(C). Such wiring methods include using Type MI (mineral insulated) cable, Type MC (metal-clad) cable without an overall nonmetallic covering, and Type AC (armored cable) cable. See NFPA 70-2005, Article 300.22(C) for additional information.



WARNING

Electrical installations installed in hollow spaces, vertical shafts, and ventilation or air-handling ducts shall be installed in a manner such that the possible spread of fire or products of combustion will not be substantially increased. Openings around penetrations through fire resistance-rated walls, partitions, floors, or ceilings shall be firestopped using approved methods to maintain the fire resistance rating. Firestopping such penetrations may be accomplished by using specially manufactured fire seals or fire-barrier caulking. See NFPA 70-2005, Article 300.21, ANSI/TIA/EIA-569-B, and NECA/BICSI 568-2001 for additional information.

6.4.7 DC POWER BUDGET

To properly size DC power cables, a DC power budget **shall** be established. Figure 6-9 shows an example power budget. Typical minimum DC operating range will be from 2.33 - 1.75 VPC. This translates to 56 - 42 V for a 48 V system, or 28 - 21 V for a 24 V system. (Some equipment will have an operating range wider than those stated here.)

The first step in establishing the DC power budget is to determine the lowest voltage in the equipment operating range, called the end voltage. Where multiple pieces of equipment are connected to a given branch, the highest of the end voltages should be used for the power budget. The difference between the equipment end voltage and the battery end voltage (1.75 VPC minimum) is the allowable voltage drop. Voltage drop from the batteries to the main distribution, main distribution to remote distribution, and remote distribution to the load is then determined by load and the distances between components.

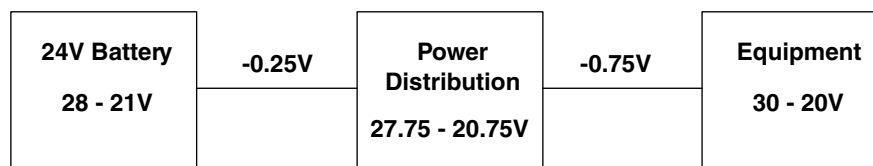

In above example:

Battery End Voltage (21V) - losses (-0.25 - 0.75V) = 20V

Therefore, minimum equipment range must be 20 V or lower.

FIGURE 6-9 DC POWER BUDGET

If the equipment end voltage is equal to or higher than the battery's end voltage, then a higher battery end voltage will have to be selected. Using a higher battery end voltage will increase the battery size required for the system. Normal battery end voltages range from 1.94 - 1.75 VPC. In these cases, the allowable voltage drop should be kept to the absolute minimum practical.

6.5 UNINTERRUPTIBLE POWER SUPPLIES

This section provides guidelines and specifies requirements for selecting and installing a site Uninterruptible Power Supply (UPS). Note that although specific recommendations are stated here, actual equipment specifications are largely determined by factors unique to the installation being performed.

The UPS system is intended to provide short-term power to specific loads when commercial power glitches or short-term power outages occur. Most UPS systems come with a standard configuration that usually provides between 5 to 10 minutes of supply voltage at full load capacity. The UPS typically provides an alarm that indicates when the UPS is nearing battery depletion.

NOTE: Extended power delivery during a utility blackout is intended to be provided by a generator. The UPS is typically intended to provide transition power only between utility blackout and generator stabilization.

NOTE: If the site will use a generator in addition to a UPS, the UPS **shall** be programmed or configured to allow the generator to provide power and not block the generator from connecting to its intended load. Note that generator power may be rejected by a default-configured UPS because of sensing circuitry in the UPS that rejects the generator power as not being “pure,” as compared to its normally received utility-supplied power. Any AC “line quality sampling” feature on the UPS should be disabled to prevent the UPS from rejecting the generator as a power source.

6.5.1 DETERMINING UPS OUTPUT REQUIREMENTS

The following requirements and considerations **shall** be observed when specifying and installing the UPS:

- UPS **shall** provide true sinusoidal output. Step-synthesized output **shall not** be acceptable.
- UPS **shall** be capable of providing full rated output power for the switchover period from utility power to stabilized generator power.
- Service panelboard **shall** have enough capacity and breaker space to accommodate the UPS.
- Intended location of UPS **shall** have adequate capability to exhaust the heat generated by the UPS.
- Ambient temperature range near UPS **shall** be in accordance with manufacturer's specification.
- Adequate spacing for safe servicing of the UPS and battery banks **shall** be considered in planning the installed location of the UPS.
- Preventive maintenance (including suggested battery replacement intervals) **shall** be in accordance with manufacturer's specifications.

6.6 ALTERNATE POWER SOURCES

Certain sites without access to commercial AC power utilities can use solar and/or wind-generated power. The solar panels and/or wind generator charges batteries that provide power to site equipment. Propane or liquid natural gas (LNG) generators can be used, especially in colder climates, to back up the solar/wind system.

Because solar/wind systems provide limited power, it is important when planning the power system to calculate the predicted power usage for the site. Solar power is best suited for small sites with low power requirements where the physical size and cost of the standalone power system does not become impractical. The site's transmitter duty cycles **shall** be planned so as not to exceed the maximum average current requirements.

Wind generators can be used to back up a solar panel system. If there are sunless days with wind then battery charging can still take place. Such a system could take advantage of more sun in the summer and more wind in the winter. Wind generators should be mounted higher than buildings or other obstructions where wind flow is more efficient.

6.6.1 SYSTEM PLANNING

Development of a stand-alone power system should be contracted with a firm experienced in the design of alternate power systems. To design a system capable of supplying the site's power needs, the contracted firm needs the following information:

- Total typical ampere-hours (Ah) used by all site equipment over a 24-hour period. (1 ampere used continuously for 1 hour is 1 Ah.)
- Voltage the power system must be capable of providing. (Communications sites of this type typically use 12 volt or 24 volt battery systems.)
- The average number of consecutive sunless days expected at the location.

The daily AH rating is calculated as shown in the following example. Given the following characteristics for a single-repeater site:

Single repeater requires 7A for Tx (A_{Tx}) and 1A for Rx (A_{Rx})

Radio link requires 1.6A for Tx and 1A for Rx

Duty Cycle (Tx/Rx) of 20%

Using the following formula: $[(A_{Tx} \times \%Tx) + (A_{Rx} \times \%Rx)] \times 24 \text{ hrs} = \text{average Ah required}$

For the example characteristics given, the repeater requirement is:

$[(7 \times 0.2) + (1 \times 0.8)] \times 24 = 52.8 \text{ AH/day}$

Radio Link requirement is: $[(1.6 \times 0.2) + (1 \times 0.8)] \times 24 = 26.9 \text{ Ah/day}$

Total requirement is: **79.7 Ah/day**

6.6.2 REQUIREMENTS

The following requirements and considerations **shall** be observed when specifying and installing a solar power system:

- Solar panels **shall** be located away from objects that could block sunlight to the panel. Panels **shall** be pole-mounted or roof-mounted if required.
- Observe the total time a particular location has direct sunlight throughout the day. Note in any calculation or specification that the site batteries are charged only when the solar panel is exposed to the sun.
- The angle of the sunlight with respect to the solar panel throughout the year **shall** be considered. Shadows cast by nearby objects may be different when the sun's angle changes with the seasons.
- Note that the fixed panel mounting angle for year round usage in northern latitudes is typically 10 degrees more than the latitude. For example, at a latitude of 45° north the panel should be mounted at an angle of 55° from the horizontal.
- The optimum angle varies throughout the year. The amount of variation increases with latitude. Have the panel supplier recommend the mounting angle. (Trackers are available that automatically move the panel to follow the sun, but these are rarely used at communications sites because of the additional maintenance and possibility of failure.)
- Solar panels **shall** be at least 10% oversized to ensure that they can handle the site's power requirements.
- Battery storage **shall** be adequate to supply power to the site for 5 to 10 days without wind or sun.
- Far northern latitudes (or far southern latitudes in the southern hemisphere) have less daily sun charging time.
- Deep-cycle batteries **shall** be used in systems experiencing up to 80% of the battery system is discharged and recharged.
- Solar panels and wind generators **shall** be mounted high enough to discourage vandalism. Bullet-resistant solar panels are available.
- Where applicable, panels **shall** be mounted high enough to clear deep winter snowfalls or ice accumulation.
- Panels **shall** be mounted and supported such that damage by high winds is avoided.
- Outside cabling **shall** be well secured and protected with conduit, or run inside the mounting pole.
- Plan the battery location in accordance with “Battery Systems” on page 6-27. In earthquake-prone areas (Moment Magnitude rating 3 or greater), batteries **shall** be mounted in seismic-rated battery racks secured to the floor.

6.6.3 INSTALLATION

Install the solar panels and wind generator in accordance with instructions provided by the contracted design firm.

- If panels are roof-mounted, the metallic portions of the solar panel framework **shall** be bonded to the site grounding electrode system in accordance with Chapter 4, “External Grounding (Earthing).”
- If panels are pole-mounted, the pole ground **shall** be bonded to the site grounding electrode system in accordance with Chapter 4, “External Grounding (Earthing).”
- It is recommended that cabling from the outdoor portion of the system be protected in conduit and secured. Cable from pole-mounted solar panels or wind generators can be run inside the mounting pole. Appropriate precautions **shall** be taken to protect the cable from moisture ingress.
- Batteries **shall** be installed in accordance with “Battery Systems” on page 6-27 and secured against earthquakes in seismically active areas (Moment Magnitude rating 3 or greater) using a seismic-rated battery rack rated for the site's seismic zone. Secure the rack to the floor per manufacturer's instructions.

6.6.4 MAINTENANCE

- Solar panels **shall** be cleaned and inspected twice a year or as required to prevent accumulation of bird droppings, dust or pollen that could reduce efficiency by blocking sunlight.
- Cracked or damaged panels **shall** be replaced.
- Manufacturers' instructions for maintaining batteries **shall** be observed.

6.7 BATTERY SYSTEMS

Batteries used for equipment backup can be divided into two categories: flooded cell (wet) and valve regulated (sealed). Flooded cell batteries pose greater hazards, because they emit hydrogen gas during normal operation. Sealed batteries do not typically vent hydrogen.

Where applicable, it is recommended that certified Hazardous Materials handlers be contracted to handle tasks involving the hazardous materials contained in most battery systems.

6.7.1 BATTERY SAFETY



WARNING

Motorola employees and contractors shall not handle hazardous materials unless properly trained. This includes warehouse storage, transportation, and installation of battery systems.



WARNING

Wet cell battery failure involving large-scale electrolyte leakage may constitute a Hazardous Material (HAZMAT) condition. Under no circumstances shall regular site personnel perform HAZMAT handling. Special training and HAZMAT certification, spill mitigation and reporting, and cleanup techniques/monitoring is required under the Federal Clean Water Act and NFPA regulations.



WARNING

Batteries used for powering equipment pose the following risks. Always use appropriate caution when working with and around batteries.

Explosion hazard resulting from inherent generation of hydrogen sulfide gas;
Chemical burn/blindness resulting from sulfuric acid electrolyte. Wash affected skin or eyes immediately with running water. Seek medical help immediately.
Very high current capabilities, with the possibility to burn, start fires, and result in arcing.

NOTE: Material Safety and Data Sheets (MSDS) describing the nature of HAZMAT materials present at a communications site, their reactivity, flammability, and emergency spill/release mitigation and reporting are required at each site.

All applicable NFPA, OSHA and local codes **shall** be followed regarding battery installations and maintenance work.

Battery manufacturer warning statements **shall** be understood and complied with. The manufacturer's statements **shall** determine the type and extent of Personal Protective Equipment required in minimizing battery handling hazards for the batteries being installed.

This section provides safety rules to be followed when working with wet cell batteries. Wet cell batteries require more stringent handling and safety precautions than dry cell batteries. In all cases, manufacturer's documentation **shall** be read and understood before installing or maintaining battery systems. Placards placed directly on the battery define the precautions required. See "Typical Battery Safety Kit" on page 3-30 for the required equipment to be provided at the site for working with batteries.

Observe the following general considerations regarding battery installation and maintenance:

- At all sites using wet cell batteries, or gel-cell batteries where manufacturer specifies eyewash or other Personal Protective Equipment, such equipment **shall** be provided in the battery containment area.

NOTE: Discard and replace bottled eyewash solution according to the expiration date on the bottle.

- Because of the chemical composition, weight, and bulk of many battery configurations, certified transporters and hazardous materials handlers may be required.
- Batteries may require two-person lift. Use proper lifting techniques and equipment to avoid injury.
- Installation personnel **shall** wear necessary safety equipment when installing batteries.
- “NO SMOKING” signs **shall** be prominently displayed in the battery room and on the exterior of the battery room entry door. Smoking, or the source of any spark producing materials, **shall** be strictly prohibited in this area.
- Batteries **shall** have insulated covers and/or insulated terminal protectors.
- Batteries **shall not** be used as a work surface.
- Batteries **shall** be covered when work is in progress above them.
- The US Federal Clean Water Act, with jurisdictional or local option by location, does not allow battery acid spills, which are neutralized, to be flushed down the drain or spilled on soil. Dispose of spills as required by local regulation.
- Jewelry **shall not** be worn while working on batteries.
- Insulated tools **shall** be used when working around batteries to minimize the potential for an accidental short circuit.
- A lightweight, acid resistant bib type apron in good working condition **shall** be permanently stored on site near the battery plant. The fabric **shall** be acid, caustic, puncture, and flame resistant.
- An acid resistant, full face shield in good working condition, **shall** be permanently stored on site near the battery plant. The shield **shall** meet all requirements of ANSI Z87.1. Protective eye wear that does not provide full face protection is not allowed.
- One pair of acid resistant gloves in good working condition **shall** be permanently stored on site near the battery plant. These gloves **shall** be of sufficient length to cover the hand, wrist, and forearm for protection from chemical splash.
- One 0.5 kg (1 lb.) box of baking soda or equivalent acid neutralizing compound **shall** be permanently stored on site near the battery plant. Water is required to mix with the baking soda.

NOTE: Discard and replace bottled eyewash solution according to the expiration date on the bottle.

- An OSHA approved emergency eyewash station **shall** be permanently mounted near the battery plant. The eyewash station **shall** use an isotonic saline wash capable of neutralizing acids or caustics and **shall** be able to flush the eye for 15 minutes. A plumbed eyewash station and a shower should be provided in battery areas if possible.
- A container of non-oxidation material for coating electrical connections **shall** be left on site.

- Where applicable, provisions **shall** be made to exhaust gases produced by batteries. For wet cell batteries the manufacturer-specified stationary battery flame-arresting vent **shall** be installed on each cell. This vent **shall** be secure, clean, and in good repair to help ensure maximum protection against potential explosion. Sealed batteries do not have an opening for adding electrolyte. However, there is generally a small vent hole that opens as required to vent internal gasses. There are two methods which may be used to vent battery gases:
 - Use an exhaust fan on a timer, changing the total room air four times per hour.
 - Use a manifold system that consists of tubing connected to each cell and vented to the outside.

NOTE: In most cases, sealed batteries do not require venting. Check local codes for applicability. Check the labels on the batteries for the proper protection based on that particular type of battery.

- Batteries **shall** be kept clean to reduce short circuit hazards, rack corrosion and the possibility of electrical shock. Clean batteries with clear water if necessary. Do not use abrasive cleaners, detergents or petroleum-based cleaning products on battery container.
- Battery banks consisting of multiple cells with circuit protection greater than 20 amperes **shall** have 12.7 mm (0.5 in.) or greater thickness polycarbonate or hard rubber protective shield installed on a support frame and securely mounted in front of the battery rack to protect personnel should there be a violent structural failure of any cell(s). This protective shield **shall** extend from 76 mm (3 in.) above to 76 mm (3 in.) below the height of the cells being protected.
- When batteries are located in an area that is accessible to persons other than qualified system maintenance personnel, an additional protective shield as described above **shall** be installed to cover the top of all cells and battery circuit conductors to prevent conductive materials from contacting battery posts or circuit conductors on top of the cells.

6.7.2 BATTERY CONTAINMENT AREA

The following requirements and considerations **shall** be observed when specifying and laying out a battery containment area:

- Certain areas may require use of UL listed Intrinsically Safe vent fans, electrical, and electronic equipment. See NFPA 70-2005, Article 500 through 505.
- NFPA signs advising the fire department of reactivity with water **shall** be posted. (NFPA 70E, Section 1-8.2.3).
- Separate battery rooms (especially for flooded cell types) that are sealed from adjoining rooms and properly vented to the building exterior are recommended. These conditions may also be required by local codes.
- Where battery systems use a total electrolyte volume greater than 3.79 L (1 gallon), cell assemblies, and containment/neutralization provisions **shall** conform with NFPA 111.



WARNING

Appropriate signage shall be present on doors leading to battery rooms and within the room itself, notifying personnel of explosion, chemical, and electrical hazards within the area. Appropriate fire extinguisher(s) shall be present in battery room, as dictated by local code.

At sites where batteries constructed with bolt-on terminal connections are used, the following items **shall** be provided:

- Connector bolt wrench (nonconductive)
- Lifting sling and spreader block if applicable
- Container of non-oxidation material for coating electrical connections
- At sites with flooded lead-acid batteries, the following items **shall** be provided:
 - Hydrometer with markings every 10 points
 - Acid-resistant container for storing the hydrometer
 - Thermometer, battery

6.7.3 BATTERY BACKUP DURATION

Typically, a two hour battery backup provision is standard practice for shelter installations. This is based on the assumption that 2 hours is the nominal amount of time in which a technician would be able to respond and correct a site power problem for most urban locations. For remote sites, 4 hours or more may be necessary to respond and take action.

Battery backup requirements can range from a few minutes to many hours, depending of the system application and customer requirements. Backup of less than one hour is considered to be a high rate of discharge application.

NOTE: Because the battery backup typically will not provide for power to the HVAC system, temperature related shutdown (due to temperature shutdown circuitry in repeaters) **shall** be considered in determining the maximum operational period under backup conditions. In some cases, thermal shutdown can occur well before basic battery exhaustion.

6.7.3.1 HIGH RATE OF DISCHARGE

If the battery plant will be used in a high rate application, or if an existing plant is to be converted to a high rate application, consult the battery manufacturer because this may require batteries specifically designed for high rate applications. High rate plants may require that the size of hardware used to connect the cell into a string be sufficiently large as to accommodate the additional heat generated by high rates of discharge.

6.7.3.2 LONG DURATION BACKUP

Battery backup of many hours may be desired, and can be designed for, but may not always be achievable. Long term outages are caused by loss of AC from the utility company and/or the standby generator. During long term outages, the HVAC (heat, ventilation, and air conditioning) system is also disabled. Depending on the site and the equipment being powered by the batteries, significant thermal rise or fall may occur. If the outage persists long enough, thermal shutdown due to loss of HVAC may be the true limiting factor in backup duration. Given the heat generated by the equipment and a potential range of outside ambient conditions, an HVAC contractor should be consulted to determine the amount of time it will take for the site to reach the high or low limits of the equipment's operating temperature range. For worse-case calculations, battery backup durations exceeding this time are not recommended.

6.7.4 BATTERY SIZING

Battery sizing can be straightforward or fairly complex, depending on the characteristics of the load being backed up. Stationary batteries (those used for fixed locations) are rated in Amp-Hours (AH).

An 8-hour duration represents a rated amperage. The amp hour rating of stationary batteries is generally stated as the number of amps a battery can deliver for an 8-hour period. For example, 100 A for 8 hours is a 800 AH battery. If durations of other than 8 hours are desired, a correction factor must be applied. Table 6-5 provides the correction factors for several durations. Note that new batteries do not deliver 100% of their rating. It takes several charge/discharge cycles to bring a battery plant to full capacity. Also, as a battery continues to age its capacity gradually falls to 80% of its initial rating, at which point it is considered to be at end of life. These characteristics should be considered when choosing batteries.

TABLE 6-5 BATTERY RATING CORRECTION FACTORS

1 Hour	2 Hours	4 Hours	6 Hours	8 Hours
1.763	1.378	1.157	1.061	1.0

The DC load for most digital systems can be assumed to be steady-state, as it does not vary (even during busy times). Multiply the load by the back-up duration, and apply the correction factor, if necessary.

For example, given a load of 32 amps and a back-up duration of 4 hours, multiply the load (32) by the duration in hours (4) and the correction factor of 1.157. This means that a battery with at least a 148 amp hour rating will be required for this application.

To calculate battery size, the power required and duration of each change must be known. Graph out the entire discharge profile. When the discharge profile is graphed, divide the discharge into blocks based on duration.

6.7.5 BATTERY RATING

Batteries **shall** be accurately sized to ensure they will maintain proper voltage for the required time duration. Use worst-case scenarios with respect to age/deterioration, lowest temperature, expected load, and the availability of alternate power generators.

6.7.6 MULTIPLE BATTERY STRINGS

General practice stipulates that battery types, ratings, and service life **shall not** be mixed among a rack. If a site is expanded, then all fresh, similar batteries **shall** be installed and the old batteries removed. A mixture of batteries results in unequal current distribution and charging, and the probability of ongoing power system problems as batteries of different ages fail.

Floor loading, growth, and system load are a few of the factors that determine the number of strings of batteries required. All battery backup systems require maintenance. Some of the maintenance operations require the batteries to be off-line. Because there is no way to predict a short duration power interruption, a minimum of two strings of batteries is strongly recommended. This will ensure some amount of battery backup should an interruption occur during battery maintenance.

Too many strings of batteries also presents a problem. Should a fault occur in one cell in one string of batteries, diagnosing and locating the fault becomes more difficult as the number of strings increases. To protect the battery plant from a catastrophic failure of a single string of batteries, overcurrent protection is necessary for each individual string in the plant. The sizing of this protection should be as follows:

$$\text{System amp capacity/Number of battery strings} - 1 = \text{Required protection}$$

Manufacturer recommendations for the maximum number of strings varies widely. Motorola recommends that the power system be initially designed for a minimum of two strings and a maximum of six strings of batteries when the system is fully implemented. This will allow some margin for excess growth should the system exceed the anticipated load of a fully implemented system.

6.7.7 BATTERY CHARGING

Batteries that have been discharged to a state below full charge must be fully recharged within 24 hours. During this process considerable charging current may flow and flooded cell batteries will give off a higher level of gas than during normal float charge. A float charge must be maintained to keep the battery in a fully charged state. Over or under charging of batteries will cause an increased need for battery maintenance and may greatly shorten the service life of the battery. It is important that the charging system is properly adjusted per the manufacturer's specifications. Overcharging and undercharging alarms **shall** be installed to ensure that battery charging problems are detected quickly.

6.7.8 BATTERY TEMPERATURE REQUIREMENTS

Battery performance and service life are significantly affected by operating temperature. For full-rated performance and maximum service life, the battery temperature should be maintained close to 24° C (75° F). The battery operating time is reduced as the temperature falls; conversely, the operating time is increased as the temperature rises. However, when batteries are subjected to elevated temperatures the service life of the battery is reduced.

Reference temperature is often overlooked in rating batteries. Battery manufacturers typically use 22.2° C (72° F) as the reference temperature. A battery operated at 0° C (32° F) produces 30% capacity, but lasts for 130% or more of the rated life. Conversely, a battery operated at 38° C (100° F) produces 130% battery capacity, but may last less than 1 year.

NOTE: If building codes do not allow batteries within the same compartment as the climatized radio equipment enclosure, outdoor battery pedestals may have to be protected from direct sunlight or elevated to prevent their burial in snow during winter (where applicable).

6.7.9 BATTERY INSTALLATION

Personal protective equipment, as dictated by battery manufacturer warning statements, **shall** be available within the battery area. A plumbed eyewash station and emergency shower should be provided if possible.



WARNING

To avoid spilling acid, do not tip batteries. Battery acid can cause severe burns and blindness if it comes into contact with skin or eyes. Wash affected skin or eyes immediately with running water. Seek medical attention immediately.

- Jewelry **shall not** be worn while working on batteries.
- Installation personnel **shall** wear necessary safety equipment when installing batteries.
- Batteries may require a two-person lift. Use proper lifting techniques and equipment to avoid injury.
- Insulated tools **shall** be used when installing battery systems.
- Battery installation **shall** conform to manufacturers specifications, the National Electrical Code (or equivalent), and all applicable national, state, and local codes. Observe the following cautions when installing batteries:
- Do not slide or drag batteries.
- Because of size, weight, and service needs, batteries are normally installed on shelves or racks. In earthquake-prone areas (Moment Magnitude rating 3 or greater), however, seismic racks **shall** be used. Seismic racks **shall** be properly secured to the floor or wall, but **shall not** be secured to both. Seismic racks **shall** be installed exactly as specified by the rack manufacturer.
- For areas with seismic rating of Moment Magnitude rating 3 or greater, appropriate rack design **shall** be used. Follow manufacturer's installation requirements.
- Racks and shelves **shall** be constructed to support the total weight of the batteries and other supporting equipment placed on them. Racks and shelves **shall** be assembled in accordance with the manufacturers specifications.
- Battery racks **shall** be bolted to the floor or wall.
- The batteries **shall** be prevented from falling due to accidental movement by installing a rim to prevent tipping, or by interconnecting batteries to prevent movement.
- Metal racks **shall** be grounded in accordance with specifications provided in Chapter 5, "Internal Grounding (Earthing)."
- Perform calculations to ensure that the floor area will support the total weight of the rack and the batteries. See "Battery Installation" on page 6-34.
- All terminal connections **shall** be tightened to manufacturers' specifications.
- A non-sparking circuit breaker of suitable size to handle maximum load and charging currents **shall** be installed in the ungrounded leg of the circuit to provide overcurrent protection. The ampacity of the circuit breaker **shall not** be greater than the ampacity rating of the circuit conductor. This device may also serve to disconnect the load during battery servicing.

- Circuit conductors, including jumpers between several cells, **shall** be jacketed copper of at least the minimum AWG size permitted for the maximum DC load. Conductor size may need to be larger than that specified to minimize voltage drop between the batteries and the equipment.
- In the U.S., DC conductor jacket colors **shall** be red (floating or ungrounded) and black (grounded). Red and black tape may be applied at each connection, splice or pull box if red and black conductors are not available. These requirements may vary by vendor product and international location.
- Conductors **shall** be enclosed in PVC or metallic conduit or raceway for protection from physical damage and **shall not** be exposed except near terminations.
- Any additional disconnect switches **shall** have an ampacity rating equal to or greater than the circuit protection device.
- Battery terminals **shall** be protectively coated in accordance with manufacturer's specifications.
- Exposed battery terminals should be protected from accidentally contacting metal objects.
- Stationary lead acid batteries **shall** be equipped with an approved spill containment system to prevent damage caused by spilled battery electrolyte whenever electrolyte capacity is greater than 4.8 liters (1 gallon). NFPA 70-2005, Article 480, BOCA 307.8.13, Universal Building Code Article 304.8. The spill containment system **shall** comprise a passive and active neutralization system.

6.7.10 BATTERY MAINTENANCE DISCONNECT

At some time it will be necessary to perform off-line maintenance on the batteries. An individual disconnect **shall** be supplied for each string of batteries for isolating a string from the rest of the system to safely perform battery maintenance. The disconnect device **shall** be such as to prevent arcing upon circuit make/break, and prevent any exposed live conductors.

Ensure that the DC supplied by the rectifier is electrically clean enough to supply equipment without the filtering characteristics of the batteries attached. Equipment damage could result if rectifier output has too much ripple.

6.8 STANDBY GENERATOR SYSTEMS

NOTE: The expected need of having a site supplied with a standby generator should be balanced against the economy of including a generator at the site. It is most likely cost-prohibitive to provide standby generators for large systems utilizing many sites. Typically, only difficult to access or remote location sites are equipped with standby generator power. An "Appleton"-type power connector can be installed at sites not equipped with a generator. In these cases, a portable generator can be conveniently connected to the site if needed.

This section describes requirements for backup/standby generators. The purpose of a backup or standby generator is to supply reliable power to critical loads during times when commercial power has failed. It is very important that generators used for this purpose be capable of reliably handling the required loads for the desired time while maintaining proper voltage and frequency. Backup/standby generators are not required to be installed to the same standards as emergency generators. The standards included in this section do not apply to emergency generators or power systems. Emergency power systems are required to comply with NFPA 70-2005, Article 700. Therefore, it is recommended to know and understand the difference between back-up/standby generator and emergency generator systems before procuring a generator equipment or installation work.

NOTE: There are certain locations where commercial power is not available and generators must be used for primary power. Primary power generators or generating systems **shall** be rated for continuous duty and **shall**, at a minimum, be installed to the standards covered in this section. All domestic installations **shall** meet NFPA 70-2005, (National Electrical Code (NEC)), and any other local governing codes applicable to continuous duty, primary power generators. Installations performed in non-domestic locations **shall** meet all applicable national and local codes. (NFPA 110)

A generator system includes the generator, along with a cooling system, a fuel supply system, a transfer switch, and a control panel with required alarms. Liquid fueled generators may incorporate the fuel tank into one housing, such as a base mounted tank. The transfer switch and control panel may also be incorporated into one cabinet. The generator may be placed outside as a stand-alone piece of equipment or inside a building or structure. The location may depend on several factors that include generator size, fuel supply, noise restrictions and space availability. Local codes may additionally dictate the fuel type allowed.

6.9 GENERATOR OUTPUT AND DERATING CONSIDERATIONS

To ensure that the backup generator can handle the power requirements of the equipment at the site, always consider the following factors when calculating generator output power requirements:

- Voltage, phase, and load requirements of the equipment to be supplied by the generator must be obtained, including unusual loads such as UPS power supplies and switched power supplies. The customer or an electrical engineer may specify these values.
- Consider site expansion. A 30% expansion factor is not unreasonable.
- Consider worse-case scenarios for generator load, such as all transmitters keyed simultaneously at a trunking site.
- Consider whether the generator load will be 3-phase or single-phase. Many generators are rated for operation with a 3-phase load and must be derated when working with a single-phase load. If the load is single phase, be certain that the generator is capable of supporting the maximum load while connected in a single-phase configuration. When balancing the single phase loads across three phases, always account for transmitter current.
- Consider physical requirements of the site. Generators may be derated based on operating altitude, type of fuel, and operating temperatures.
- The generator **shall not** be used under conditions that could exceed the manufacturer's specifications for the particular generator equipment.

6.9.1 GENERATOR PLACEMENT

All generators **shall** have an adequate supply of fresh air to ensure proper operation and extend life. Air is required for safe and efficient combustion as well as to cool the engine and generator. The type of engine cooling is determined by the capacity of the generator. Most generators above 7.5 kW utilize water-cooled engines; generators below 7.5 kW typically use air-cooled engines. The rate of airflow required for cooling is specified by the manufacturer. Manufacturer's guidelines **shall** be followed to ensure proper operation.

NOTE: The type of fuel used for a generator dictates the elevation of the fuel tank relative to the generator. A liquid-fuel generator (diesel or gasoline) will require that the fuel tank be upgrade from the generator fuel inlet such that the generator remains primed. Conversely, because gases rise, an LPG or natural-gas powered generator **shall** be placed upgrade from the fuel source outlet port.

6.9.1.1 GENERATORS LOCATED INDOORS

If the generator is to be located inside a separate structure or within the site building, the following requirements **shall** be met:

- Personnel safety and vulnerability of the generator to damage **shall** be considered, especially if the generator is to be installed without a protective housing. Moving engine parts and the exhaust system may be exposed, which could pose a hazard. Guards or shields **shall** be installed on exposed engine parts that could pose a safety hazard to personnel.
- The generator **shall** be located in an area accessible only by authorized personnel.
- Provide adequate spacing for service to the generator in accordance with NFPA 70-2005 and state and local codes (or equivalent). Generally, a minimum spacing of 914 mm (3 ft.) on three sides is acceptable.
- Manufacturer's specifications **shall** be followed to ensure proper ventilation, fuel supply, and engine exhaust.
- Properly sized air intake and exhaust ports **shall** be installed and maintained. The exhaust air from the radiator area of the generator in most cases is ducted to the outside.
- A louver or shutter should be installed on the exterior of the duct to close off the duct when the generator is not running. The shutter should open automatically when the generator begins operating
- A motorized louver or shutter should be installed on the air intake to close off the duct when not in use. The shutter should open automatically when the generator begins operating.
- The concrete foundation for the generator should be separate from that of the general structure. An inset sub-foundation set within a well in the overall foundation will help isolate transmitted vibration and noise emanating from the generator.
- Ensure that there is an adequate fresh air supply. Should the fresh air supply not be adequate, air will be drawn through doors, or possibly through existing vent pipes, causing a down draft of these vents. This could draw undesirable or potentially harmful fumes or gases back into the room or building. This could be a major concern in manned buildings. Check local codes for recommendations and guidance in this area.
- Fuel supply lines **shall** be no smaller in diameter or of greater length than that specified by the manufacturer. These lines should be routed and installed such that they are protected from potential damage.

- The engine exhaust system pipe and muffler **shall** be no smaller in diameter or of greater length than that specified by the manufacturer.
- In areas where the noise levels exceed 85 dBA, warning signs and hearing protection **shall** be provided.

6.9.1.2 GENERATORS LOCATED OUTDOORS

If the generator is to be located outdoors, the following requirements **shall** be met:

- The generator **shall** be enclosed in a housing sufficiently rugged to protect against weather, animal/insect ingress, and tampering. This is especially important for the radiator and fuel tank.
- The generator **shall** be enclosed within a fenced area, with adequate distance between the fence and the equipment for servicing.
- A muffler **shall** be used to minimize noise. If the generator is installed near other buildings, a muffler suitable for use in residential areas **shall** be used.
- The engine exhaust **shall** be equipped with a rain cap.
- Locate the generator such that wind will not likely carry dust and moisture into the housing nor exhaust gases into the building.
- Locate the generator such that required ventilation may be achieved. Most generators exhaust air outward through the radiator.
- In colder climates other considerations apply. An engine block heater may be required to keep the engine oil usable.
- Grade relative to fuel source/fuel inlet **shall** be appropriately considered.

6.9.2 FUEL SUPPLY

Generators may be operated from diesel, liquid propane or gaseous (propane or natural gas) fuels. Domestically, state and local codes **shall** be observed because different areas of the country have unique requirements. Fueling requirements in non-domestic locations **shall** meet all applicable national and local codes.

When selecting a generator, determine the standard fuel source for the area and use it whenever possible to ensure that an adequate fuel supply is available. Where available, utility-provided natural gas provides the most reliable fuel source and releases the installation from concerns regarding fuel tanks.

In general, the following fueling considerations **shall** be observed:

- **Liquid Propane Gas (LPG)** is considered the best all-around backup generator fuel. If possible, an LPG-configured generator should be considered.
- **Diesel and gaseous propane** are not well-suited for cold climates. Diesel is no longer allowed for new generator systems on US Federal lands due to ground contamination concerns. Diesel requires regular anti-bacterial treatment and water drainage. Diesel must be replaced with fresh fuel periodically.
- **Natural gas** requires a reservoir tank in addition to the supply line. If the supply line is severed, then the generator immediately stops. If natural gas is used, the generator output power will typically be reduced by 20%, as compared to gasoline. Generator output must be derated accordingly in these cases.

- **Gasoline** is a poor fuel for remote generators, with a limited storage life and highly flammable properties. Gasoline generators also have difficulty with remote starting.
- Liquid fuel storage tanks **shall** be equipped with secondary containment capable of retaining 110% (or greater) of the maximum volume of fuel stored.
- The storage tank secondary containment **shall** be designed such that storm water and debris cannot collect inside it.
- All fuel lines or other system components that extend beyond the storage tank secondary containment area **shall** be designed with secondary containment.
- Local Environmental Protection Agency (EPA) rules **shall** be adhered to following a fuel spill. All fuel spills **shall** be cleaned up.
- Fuel storage tanks are required for all fuels except natural gas, which is provided by a utility. (However, a storage tank in conjunction with utility-provided natural gas provides additional backup in the case of gas main breakage.) Manufacturer specifications as to size and length of fuel supply lines as well as lift **shall** be followed.
- Fuel storage tanks located outside of a structure should be protected from damage and tampering, and **shall** be enclosed within a fenced area. In many areas local codes require a double wall construction for the tank or a catch basin to prevent fuel from contaminating the site. Minimum recommended distance between the storage tank and fence is 1.2 m (4 ft.); minimum recommended distance between the tank and site building is 3 m (10 ft.). See NFPA 58 for additional information.
- Fuel storage tanks **shall** be secured to concrete pads using captive hardware.
- LPG fuel tanks **shall** utilize a fuel vent pressure relief valve. The relief valve vent **shall** be directed away from the tank, sources of ignition, and flammable material.
- Fuel lines **shall** be protected within the fuel storage area as well as along the route to the generator. Location and installation of the fuel tank and fuel lines **shall** meet all applicable environmental, building, and fire safety codes.
- All generator installations **shall** be equipped with secondary containment capable of retaining 110% of the volume of the largest tank within the containment structure, if the tanks system is a single-wall system. Alternatively, if the tank system is a double-walled system, the system **shall** be designed with interstitial monitoring devices that is capable of detecting a leak in the primary or secondary containment system unless tertiary containment is provided (for example, a convault or equivalent). Special tanks (double wall or fiberglass) and containment barriers are strongly recommended. Earthquake prone areas may require special fuel line considerations. Local codes and manufacturer's recommendations **shall** be followed.
- In potential flood zones, above ground fuel tanks should be secured with a safety cable around the tank attached to an anchoring device in the soil. This helps prevent the tank from breaking loose and floating away during a flood condition.
- Critical placement and orientation of the tank pressure relief valve is required. This is required, in the case of a fire, to prevent an over-pressure gas release cloud from feeding its own fire.

6.9.3 TRANSFER SWITCH

A transfer switch **shall** be installed to perform the switching between commercial power and standby power. This switch is generally collocated with the site electrical service panel. In general, the following considerations need to be observed:

- The switch **shall** have an ampere rating equal to or greater than the ampere rating of the circuits to be transferred.
- The transfer switch is generally located inside a building; however, if the transfer switch is enclosed in an approved watertight housing it may be located outside.
- Many areas require a disconnect switch in the feeder cabling between the generator and the transfer switch. This facilitates generator servicing and provides an additional safety device to prevent AC power backfeed into the commercial service.
- The neutral-ground bond **shall not** be made in the transfer switch.
- For domestic sites, installation of the transfer switch **shall** follow the manufacturer's recommended installation guidelines as well as meet all applicable NFPA 70-2005, national, state and local codes. Installations performed in non-domestic locations **shall** meet manufacturer's recommended installation guidelines, as well as all applicable national and local codes.
- Surge suppression **shall** be installed. See Chapter 7, "Surge Protective Devices."

6.9.4 ELECTRICAL WIRING CONSIDERATIONS

When designing the interconnection wiring between the generator, transfer switch, and site AC mains, the following considerations **shall** be observed:

- There **shall** be two sets of circuit conductors run between the transfer switch and the generator. One set **shall** be for low voltage control/alarm circuits and the second set for the electrical service. Each set **shall** be installed within its own dedicated conduit/raceway.
- The control/alarm circuits **shall not** be installed within the same conduit or raceway as the electrical service. (See NFPA 70-2005, Article 800.133 for additional information.)
- Conduits/raceways **shall** be sized and routed per the NFPA 70-2005, code (or equivalent in non-domestic installations) and any other applicable national or local codes.
- A dedicated protected electrical circuit **shall** be provided at the generator for engine/battery heaters and service equipment. If located outside, this circuit **shall** have ground fault protection.

6.9.5 INSTALLATION PLAN

Standby generator system installations **shall** be carefully planned and properly installed to ensure proper operation for extended periods. All requirements for the proper location of the generator, properly sized and positioned vents for the required airflow, fuel storage or supply, exhaust system placement and electrical connections **shall** be reviewed by a qualified engineer or inspector to ensure compliance with applicable NFPA 70-2005, national, state and local codes. In general, the following considerations need to be observed:

- Care **shall** be taken to ensure that exhaust gas discharged from the exhaust system **shall** disperse into the open atmosphere and will not be blown or drawn into the building interior. Proper precautions **shall** be taken when generators are installed within or in close proximity to occupied structures.
- Foundation size **shall** be determined based on the geographic area where the system is being installed.
- Door sizes, as existing in the finished structure, **shall** be considered to allow removal/replacement of the largest generator subassembly from within the structure.
- Rain hoods over intake and exhausting vents **shall** be designed to accommodate local extreme environments. Where the potential of high snowfall or drifting is possible, the vent hood **shall** be placed at an appropriate level and directed away from the elements.

NOTE: On radiator cooled generators, cooling air inlet **shall** be at least 1½ times larger than radiator duct receptacle area. Flow of cooling air and heated air should be controlled by automatically operated louvers.

- Earthquake prone areas (Moment Magnitude rating 3 or greater) may require special design and installation features, especially in the area of fuel lines, fuel storage, exhaust system and muffler supports. Appropriate geological information should be consulted regarding seismic considerations.
- For indoor installations, ensure that maximum floor loading will not be exceeded. Shock mounts are recommended and may be required on some installations to minimize vibration transfer.
- Batteries not required for operation of the generator **shall not** be located within a room containing a generator unless the room is properly ventilated.
- Manufacturer's guidelines and specifications to ensure proper air exchange for the generator room **shall** be followed.

6.9.6 ALARMS, METERS AND GAUGES

NOTE: Consideration **shall** be given to assure that remote alarm reporting systems are independent of the power systems they monitor. The reporting system **shall** be such that if the phone line breaks, the primary power source fails, or the common battery bank depletes, then alarms will still be transported.

- All generators **shall** be equipped with an engine high temperature alarm/shutdown and low oil pressure alarm/shutdown.
- All generators **shall** be equipped with an oil pressure gauge.
- Frequency, Voltage and Amp meters are also recommended and should be installed either at the generator control panel or at the transfer switch.
- Additional meter, gauge, remote alarm, engine and battery heater options and needs **shall** be considered. These alarms, if monitored, can provide an early warning to impending problems, thereby reducing cost and down time significantly.

6.9.7 GENERATOR INSTALLATION GROUNDING

All generators, fuel storage tanks above or at grade level, and fences discussed within this chapter **shall** be grounded as described below.

6.9.7.1 INDOOR GENERATOR GROUNDING

Generator systems located indoors **shall** be bonded to the internal grounding system as follows:

- Using the intended chassis grounding connection on the generator, the generator **shall** be bonded to the internal Master Ground Bus Bar in accordance with methods specified in Chapter 5, “Internal Grounding (Earthing).”
- A transfer switch (if not part of the generator unit) **shall** be bonded to the interior Master Ground Bus Bar in accordance with methods specified in Chapter 5, “Internal Grounding (Earthing).”

6.9.7.2 OUTDOOR GENERATOR GROUNDING

Generator systems located outdoors **shall** be bonded to the external grounding system as follows:

- Using the intended chassis grounding connection on the generator, the generator **shall** be bonded to the external site Ground Ring in accordance with methods specified in Chapter 4, “External Grounding (Earthing).”
- If a metallic fuel tank is utilized, the fuel tank **shall** be bonded to the external site Ground Ring in accordance with methods specified in Chapter 4, “External Grounding (Earthing).”
- Metallic fencing surrounding the generator installation **shall** be bonded to the external site Ground Ring in accordance with methods specified in Chapter 4, “External Grounding (Earthing).”
- A transfer switch (if not part of the generator unit) is typically installed in the site building or shelter and collocated with the site electrical service panel. In this case, the transfer switch **shall** be bonded to the interior Master Ground Bus Bar in accordance with methods specified in Chapter 5, “Internal Grounding (Earthing).”

6.9.8 GENERATOR INSTALLATION

The generator system **shall** be installed using all manufacturer's recommended installation practices. In general, observe the following considerations:

- In outdoor installations all foundations **shall** be of proper size to support the load (check local codes for special considerations).
- The generator, fuel tank(s), transfer switch/control panel and all associated components **shall** be securely fastened to the intended foundations.
- Fuel lines **shall** be adequately secured, protected and free of leaks.
- All parts of the system **shall** be installed in such a manner that it **shall** be easily serviceable without undue safety risk while the equipment is operational.
- Installations in earthquake prone areas (Moment Magnitude rating 3 or greater) may require additional fuel, exhaust system and muffler supports. Manufacturer recommendations and local codes **shall** be followed in these areas.
- In earthquake prone areas (Moment Magnitude rating 3 or greater), it is recommended that standby generators be installed on vibration isolators, with flexible cables used for electrical and grounding, and flexible tubing be provided for fuel systems.

6.9.9 GENERATOR STARTUP

Most generators ship without oil and coolant. Many times fuel lines are not connected. An authorized manufacturer's service representative should be used to review the installation, prepare and start the generator. Observe the following considerations:

- All fluid levels **shall** be checked to ensure adequate supply prior to actual startup.
- The generator **shall** be checked for proper voltage and frequency while operating with and without load. These **shall** be within manufacturer's specifications or no greater than a 3% variation from rated voltages and 5% overall variation from specified frequency.
- Setting of all controls within the transfer switch/control panel **shall** be verified and checked to ensure proper load pickup, transfer, re-transfer and shut down.
- The charge rate of the battery charger should be checked.
- The exercise clock should be set and proper operation should be verified. The exercise clock **shall** be set to exercise the generator at a minimum of 30 minutes every 7 days. It is strongly recommended to exercise the generator under full load.
- All alarm connections **shall** be verified and functions tested.
- The fuel system and exhaust system **shall** be checked to ensure there are no leaks.
- Check to ensure that all safety shields and covers are in place.
- If a UPS system is employed in this configuration, tests **shall** be conducted to ensure the UPS functions properly when being fed by the generator. If a problem occurs, frequency and voltage tolerances may need to be reviewed.

6.9.10 GENERATOR SAFETY

In general, the following safety precautions **shall** be observed:

- All moving parts **shall** be enclosed or protected.
- Safety shields and covers **shall** be in place except as necessary for service.
- Hot surfaces such as engine exhaust pipes and mufflers **shall** be protected to ensure that there is no accidental contact by foreign material or persons.
- “No Smoking”, “Caution: Hearing Protection Required”, and “Automatic equipment, may self-start” signs **shall** be posted within a generator room or adjacent to a generator which is located in a room with other equipment.
- Points where exhaust system components pass through walls **shall** have approved feedthrough thimbles installed.
- Fuel lines **shall** be protected from accidental damage.
- Electrical circuits **shall not** be exposed.
- Ensure that exhaust gases disperse and are not drawn back into the interior of the building.
- All manufacturer's safety guidelines **shall** be followed during installation and operation.
- Ensure that generators installed in earthquake prone areas meet all safety requirements for an installation in that area.

THIS PAGE INTENTIONALLY LEFT BLANK.

SURGE PROTECTIVE DEVICES

This chapter includes the following topics:

- “Technologies Available” on page 7-4
- “Suppression Mode Definitions” on page 7-4
- “AC Power SPD Requirements” on page 7-5
- “Telephone/Control/Data Network Circuit SPDs” on page 7-34
- “RF Components Protection” on page 7-36
- “GPS Receiver Protection” on page 7-44
- “Tower Lighting Protection” on page 7-45
- “Battery Powered Protection” on page 7-47
- “AC Power Line SPD Test Certification Requirements” on page 7-47

7.1 INTRODUCTION

The installation of Transient Voltage Surge Suppression (TVSS) devices is a requirement for all communication sites and is essential for all facilities where communication-related electronics and electrical equipment is in use. Surges and transient power anomalies are potentially destructive electrical disturbances, the most damaging being over-voltage occurrences and short duration over-voltage events. Sometimes referred to as “spikes”, high-energy transient power anomalies can arise from inductive load switching or other events within the power system or capacitive and inductive coupling from environmental events such as nearby lightning activity. Environmental and inductive power anomalies are wideband occurrences with a frequency range from close to DC to well into the RF high frequency spectrum. It is critical that each point-of-entry (AC, telephone, LAN, signal/control and RF) into the equipment area be protected against these anomalies. This protection is essential to reduce the risk of personal injury, physical equipment damage, and loss of operations (equipment down time). Although lightning can cause the most visible damage, it is not the predominant cause of transient voltages.

Transient voltage sources include, but are not limited to the following:

- Power company switching
- Generator transfer
- Shared commercial feeders with poor line regulation
- Load switching
- Fault currents
- HVAC units
- Heating elements
- Power tools
- Electric motors
- Fluorescent lights

- Elevators
- Switching of inductive loads
- Lightning activity

There are four major site entrances for surges that require individual attention in order to effectively protect a site and reduce the probability of damage.

- AC Power
 - Main service
 - External branch circuits or feeders
 - Generator
- Telephone/Data
 - Data circuits
 - LAN
 - Control
 - Security and card access
 - CCTV
- RF Cabling
 - Antenna transmit and receive lines
 - Cable TV service
- Tower Lighting Systems

Effective grounding or earthing alone will not protect a communications facility from damage due to surges, transients, and lightning. However, an effective combination of facility grounding, equipment bonding, and properly installed Surge Protection Devices (SPDs) on all circuit conductors entering the equipment area can significantly help maximize total site protection.

**CAUTION**

Transient voltage surge suppression (TVSS) techniques using surge protection devices (SPD) alone are not enough to adequately protect a communications site. Proper grounding (earthing) and bonding shall be incorporated at a communications site in order to provide an adequate level of protection. See Chapter 4, “External Grounding,” and Chapter 5, “Internal Grounding” for grounding and bonding details and requirements.

NOTE: The term “SPD” is used interchangeably with TVSS. IEEE C62.45 and UL defines TVSS as an SPD.

Figure 7-1 on page 7-3 shows the minimum SPD installation complement for a typical communications facility.

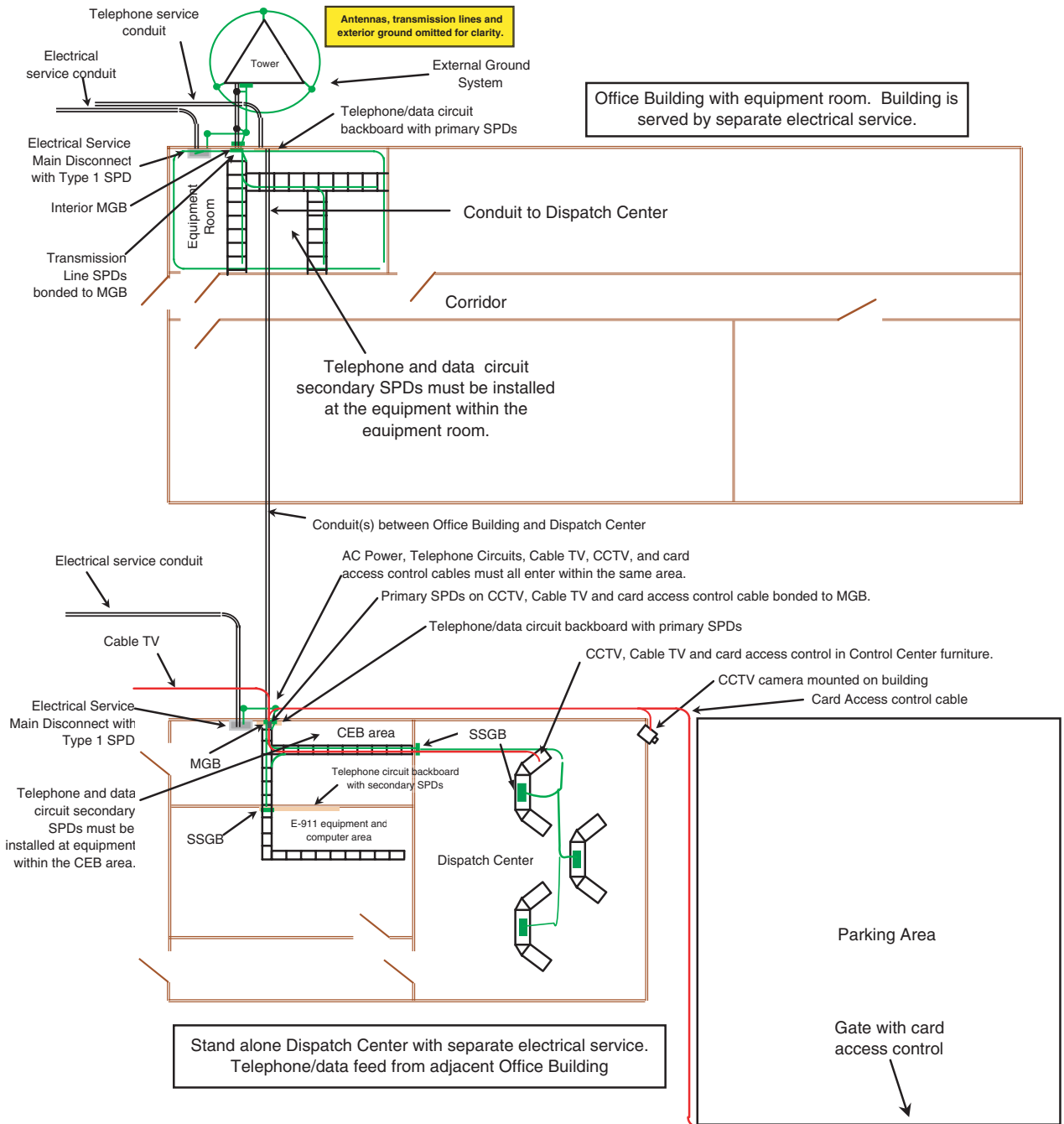

FIGURE 7-1 MINIMUM REQUIRED SPD FOR TYPICAL INSTALLATION

The requirements presented in this chapter will provide a suitable level of protection for communications equipment and sites in most areas. Areas subject to more severe lightning activity will require additional SPD design considerations which are beyond the scope of this chapter.

The ultimate goal of Transient Voltage Surge Suppression is to keep communications sites and systems operating reliably. Failure of a single SPD at a communications site would leave the site vulnerable to further damage. To maintain a backup level of protection, it may be necessary to install a redundant SPD. Another important design philosophy is that the AC power SPDs **shall not** cause interruptions to the site power when it operates. Therefore, to reduce this probability, all AC power SPDs **shall** be designed for and installed as parallel devices. A suitable disconnecting means **shall** be provided to permit servicing. Type 3 devices could be considered a series connected device as this is placed between the receptacle outlet and the load. In the Type 3 devices the surge protection medium **shall** be parallel connected between the phase conductor and the neutral conductor in a manner that will not interrupt power to the load should the surge suppression device fail. Alarms to report a device failure are recommended.

7.2 TECHNOLOGIES AVAILABLE

There are several major types of SPD technologies available today. The most common and most reliable are the Metal Oxide Varistor (MOV) and the Silicon Avalanche Diode (SAD) devices. These devices are ideal for protection of power and telephone or data circuits because of their fast response time and high energy handling capability. There are other components such as gas discharge tubes, spark gaps, surge relays, capacitors, inductors, and selenium devices that, although somewhat effective in specific applications, are not acceptable as power, telephone or data circuit SPDs at communications facilities as the typical response time is too slow.

It may be necessary to use more than one type of component in a protective device to obtain the best possible combination of SPD characteristics. The most common combination forming a “hybrid circuit” incorporates a high current, slower-acting component with a faster acting, but lower-power rated component. For AC power, this is typically a coordinated MOV and SAD combination.



WARNING

Gap Type SPDs shall not be used as AC power line surge suppression devices in TN-C-S grounding systems, common in North America. However, in TT grounding systems, typical for those countries that follow the IEC grounding system, Gap Type SPD's are the one of the preferred components in a common mode protection scheme, as long as the device meets the follow-current requirements detailed in this chapter.

7.3 SUPPRESSION MODE DEFINITIONS

Normal Mode is defined as voltage appearing between line and neutral (L-N) and line to line (L-L) conductors.

Common Mode refers to voltages appearing between line or neutral conductors and ground (L-G or N-G).

**WARNING**

Common Mode AC power surge suppression devices shall not be utilized. These devices may fail in a short circuit condition. Should this occur, the AC power neutral conductor becomes bonded to the ground or equipment grounding conductor causing undesired currents in the ground or equipment grounding conductor(s). This may constitute a personnel safety hazard and could constitute an NFPA 70 violation by creating a neutral-ground bond at a location other than at the main service disconnect. (Common Mode surge suppression devices may be used on telephone or data circuits.)

**WARNING**

All AC power SPDs used within the United States shall be UL 1449, 2nd Edition (or later revision) listed.

NOTE: There may be specific nondomestic applications where common mode protection may be advantageous although not recommended by Motorola. Installation of a transformer creating a separately derived electrical system is recommended for these applications. The SPD manufacturer should be contacted regarding these applications.

In non-domestic applications that have power systems based on the TT grounding scheme, the utilization of Gap Type SPDs in the line-to-ground, or neutral-to-ground configuration is the preferred methodology. However, the GDTs must be preceded by circuitry that limits the follow current to the levels defined further within the specification.

7.4 AC POWER SPD REQUIREMENTS

SPDs are required on all power feeders to and from communications facilities. All devices **shall** be installed per the manufacturer's installation instructions. The facility grounding and bonding systems **shall** be properly implemented to help ensure that the electrical service, all surge suppression devices, and the communication system components within the equipment area are at the same ground potential. This is **critically important** to help ensure maximum safety of personnel and maximum effectiveness of the SPDs.

The SPDs **shall** be installed within the equipment shelter, room or area to achieve maximum effectiveness. Installation at locations away from the equipment area **shall not** be performed, as it reduces the effectiveness of the SPD.

7.4.1 AC SPD REQUIREMENTS BASED ON FACILITY DESCRIPTION

Table 7-1 on page 7-7 specifies the minimum AC power SPD requirements for various communications facilities. (The voltage and phase requirements are site specific and depend on the electrical service characteristics for the specific location.)

7.4.1.1 DETERMINING REQUIRED SPD COMPLEMENT

Use Table 7-1 to determine the SPD complement best suited for a particular application as follows:

1. In the **Service Type** column, note the type of electrical layout that best describes the site, facility or equipment location.
2. Review the **Interconnect Diagram (A through M; Figures 7-2 through 7-14)** associated with the **Service Type** to ensure the electrical service and distribution arrangement selected best matches the site, shelter or equipment area. (Figures 7-2 through 7-14 are on pages 7-11 through 7-23, respectively.)
3. Order and install the Type SPD(s) correspondingly listed for the selected service and distribution system.

EXAMPLE: Assuming a stand-alone shelter as follows:

- Without a generator
- Main disconnect and all disconnects located within the shelter

SPD requirements are determined as shown below.

Service Type	Interconnect Diagram (Fig. No.)	Main Disconnect	Main Panelboard or Feeder Side of ATS	Utility Panelboard	Utility Panelboard in Other Bldg./ Shelter
Stand-alone Building/shelter without Generator					
Main disconnect and all panelboards located within the same shelter, room or equipment area	A (Figure 7-2)			Type 1 ¹	

In this example, a shelter with main disconnect and panelboard all located within shelter fits the description shown above and additionally matches Figure A. As such, the SPD type and location is correspondingly shown above.

For a given application, the SPDs **shall** be installed at the panelboard correspondingly specified in Table 7-1 and the associated figure.

Installation of a Type 3 device is also recommended for high exposure locations when the branch circuit is greater than 3 m (10 ft.) of conductor length or 1.5 m (5 ft.) of circuit length from the panelboard where a Type 1 device is installed.

7.4.1.2 INSTALLATION WITH MAIN DISCONNECT AWAY FROM AREA

For installations where the main disconnecting means is located away from the shelter, room or equipment area (Diagrams **B** through **J**; Figures 7-6 through 7-11 on pages 7-15 through 7-20, respectively), a separately derived electrical system is an option within the shelter, room or equipment area to establish the neutral-ground bond. Other means are described in “Location of Neutral-Ground Bond” on page 6-4.

A separately derived electrical system can be achieved by installation of a step down or isolation transformer, or by the installation of a suitable UPS that qualifies as a separately derived electrical system. Similarly, when a power feed is provided to another building, shelter or equipment area (Diagrams **K** through **M**; Figures 7-12 through 7-14 on pages 7-21 through 7-23, respectively), a separately derived electrical system should be installed within that shelter, building or equipment area to minimize potential damage resulting from power line anomalies generated by loads or lightning activity within that shelter, building or equipment area.

7.4.1.3 INSTALLATION WITH EQUIPMENT INSTALLED IN POLE OR PAD MOUNTED CABINETS

For installations where the equipment is installed within pole or pad mounted cabinets (Diagrams **N** through **P**; Figures 7-15 through 7-17 on pages 7-24 through 7-26), SPDs are required as specified in Table 7-1. Where a pole or pad mounted cabinet is installed and the electrical feeder originates from within another building or shelter (Diagram **Q**; Figure 7-18 on page 7-27), a Type 3 SPD is required to be installed on all equipment within the cabinet. In installations of this type it may be desirable to install additional SPDs at the branch circuit panelboard. Where the level of exposure is high a Type 1 SPD is recommended. See Table 7-1 and footnotes for further information.

NOTE: Single conversion (forward transfer mode) UPS systems do not provide transient voltage surge suppression. Double conversion (reverse transfer mode or rectifier-inverter) UPS systems offer surge suppression to source induced transients. No surge suppression is afforded for load induced transients on either type.

TABLE 7-1 REQUIRED TVSS PROTECTION FOR VARIOUS SERVICE TYPES

Service Type	Interconnect Diagram (Fig. No.)	Main Disconnect	Main Panelboard or Feeder Side of ATS	Utility Panelboard	Utility Panelboard in Other Bldg./Shelter	Equipment (If > 3 m (10 ft.) from panelboard)
Stand-alone Building/shelter without Generator						
Main service disconnect and all panelboards located within the same shelter, room or equipment area	A (Figure 7-2)			Type 1		Type 3 ¹
Main service disconnect located outside the equipment area (greater than 3 m (10 ft.)): • At fence or property line utilizing a separately derived system supplying equipment area	B (Figure 7-3)			Type 1		Type 3 ¹

TABLE 7-1 REQUIRED TVSS PROTECTION FOR VARIOUS SERVICE TYPES (CONTINUED)

Service Type	Interconnect Diagram (Fig. No.)	Main Disconnect	Main Panelboard or Feeder Side of ATS	Utility Panelboard	Utility Panelboard in Other Bldg./Shelter	Equipment (If > 3 m (10 ft.) from panelboard)
<ul style="list-style-type: none"> Within other building or structure utilizing a separately derived system supplying equipment area 	C (Figure 7-4)			Type 1		Type 3 ¹
Stand-alone Building/shelter with Generator						
Main service disconnect and all panelboards located within the same shelter, room or equipment area	D (Figure 7-5)	Type 2 or Type 1 ²		Type 1		Type 3 ¹
Main service disconnect located outside the equipment area (greater than 3 m (10 ft.)):						
<ul style="list-style-type: none"> At fence or property line utilizing a separately derived system supplying equipment area 	E (Figure 7-6)		Type 2 or Type 1 ²	Type 1		Type 3 ¹
<ul style="list-style-type: none"> Within other building or structure utilizing a separately derived system supplying equipment area 	F (Figure 7-7)		Type 2 or Type 1 ²	Type 1		Type 3 ¹
Equipment Area Located within a Larger Structure without Generator						
Main service disconnect located in another part of same structure utilizing a separately derived system supplying equipment area	G (Figure 7-8)			Type 1		Type 3 ¹
Main service disconnect located within another structure utilizing a separately derived system supplying equipment area	H (Figure 7-9)			Type 1		Type 3 ¹
Equipment Area Located within a Larger Structure with Generator						
Main service disconnect located in another part of same structure utilizing a separately derived system supplying equipment area	I (Figure 7-10)		Type 2 or Type 1 ²	Type 1		Type 3 ¹
Main service disconnect located within another structure utilizing a separately derived system supplying equipment area	J (Figure 7-11)		Type 2 or Type 1 ²	Type 1		Type 3 ¹

TABLE 7-1 REQUIRED TVSS PROTECTION FOR VARIOUS SERVICE TYPES (CONTINUED)

Service Type	Interconnect Diagram (Fig. No.)	Main Disconnect	Main Panelboard or Feeder Side of ATS	Utility Panelboard	Utility Panelboard in Other Bldg./Shelter	Equipment (If > 3 m (10 ft.) from panelboard)
Feeder From Same Service Feeds Another Building or Shelter with Equipment on Same Service in Both Buildings or Shelters						
Feeder (no generator backup)	K (Figure 7-12)			Type 1	Type 1	Type 3 ¹
Generator backed feeder	L (Figure 7-13)		Type 2 or Type 1 ²	Type 1	Type 1	Type 3 ¹
Generator and UPS backed feeder	M (Figure 7-14)		Type 2 or Type 1 ²	Type 1	Type 1	Type 3 ¹
Pole or Pad Mount Cabinets with Independent Dedicated Service						
Complete System without Generator	N (Figure 7-15)			Type 1		Type 3
Complete System with Generator	O (Figure 7-16)	Type 1		Type 1		Type 3
Stand Alone Equipment (Single Repeater, Base Station, Receiver or Control Station)	P³ (Figure 7-17)			Type 1		Type 3
Branch Circuits						
Stand Alone Equipment (Single Repeater, Base Station, Receiver or Control Station)	Q (Figure 7-18)			Type 1		Type 3 ³

1. A Type 3 device is **optional** for these installations.
2. A Type 1 device is **optional** for these installations.
3. A Type 3 device is **required** for these installations.

TABLE 7-2 APPLICATION TYPE DESIGNATION FOR NETWORK SPDs

Application Type Designation	Circuit Characteristics Bandwidth	SPD Requirement	Typical Service Applications	Safety Listing (one or both)	Peak Short Circuit (peak amperes)	Current Waveform (µs)	Life Operations
A Primary SPD intended for use at end of paired conductor spans from a common carrier or as inter-building spans	Up to 1.1 MHz operating bandwidth	Voltage limiter and non-resetting current limiter Voltage limiter and resetting current limiter	Voice, ISDN, ADSL, SDSL, T1/E1-Carrier, Alarms	UL 497, CE	1000 +/-	8/20 µs	10
B Secondary SPD intended for use as a voltage limiting device at network equipment	Up to 16 MHz operating bandwidth	Voltage limiter Voltage limiter with fast resetting current limiter	HDSL, VDSL, T1/E1, Ethernet, Gigabit Ethernet	UL 497A, CE	100 +/-	10/1000 µs	300
C Primary SPD applied externally to network-powered broadband communications coaxial, ethernet and Power Over Ethernet (POE)	Up to 5 GHz operating bandwidth	Voltage limiter	Voice, Audio, Data, Video	CE	100 +/-	8/20 µs	10

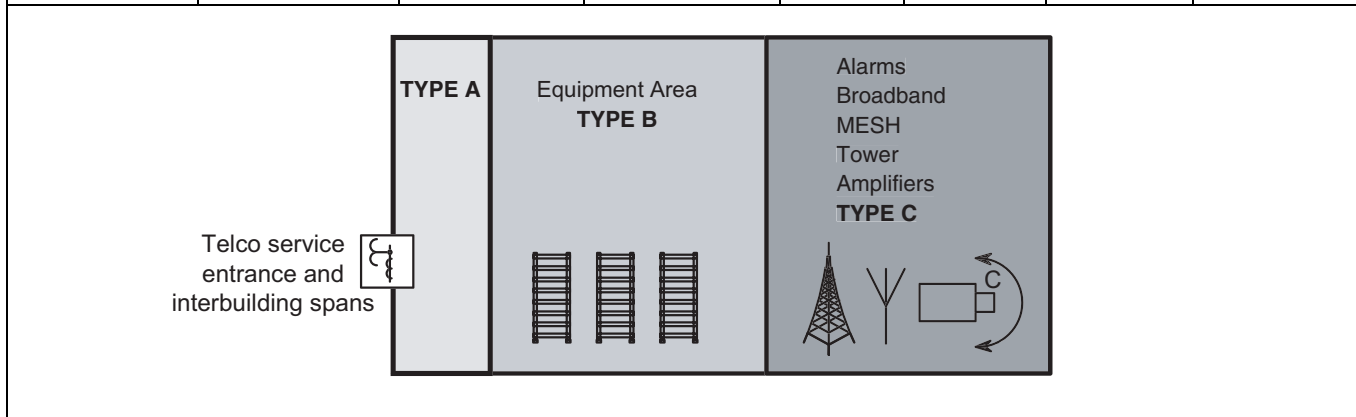

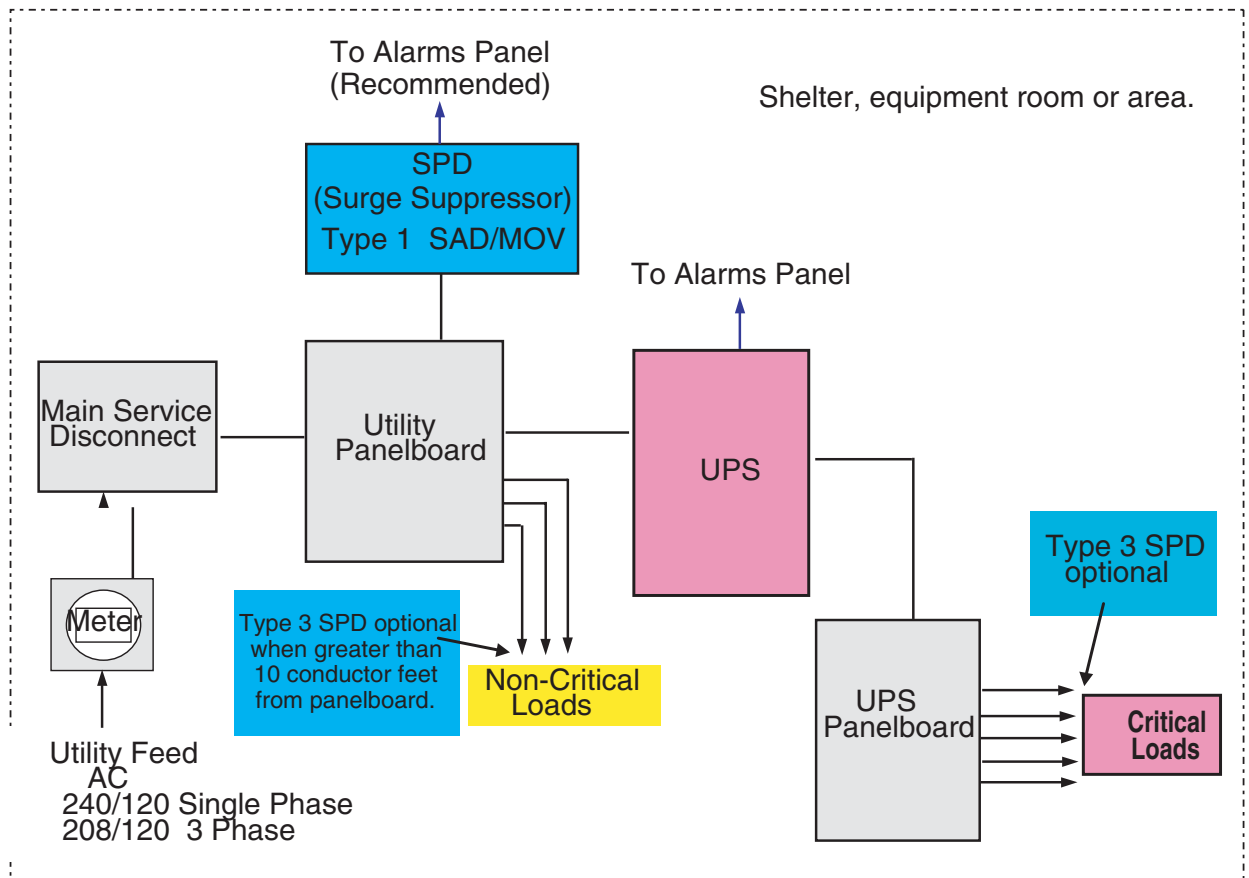

- NOTES:
1. The main service disconnect may be an integral part of the Utility Panelboard.
 2. The main service disconnect and Utility Panelboard are collocated within the equipment area.
 3. The Type 1 SPD shall be installed per the manufacturer's installation instructions.
 4. All conductors between the SPD and the associated disconnecting device (60 Amp Circuit Breaker typical) shall be as short as possible and routed together with a minimal number of bends or angles of less than 90 degrees.
 5. The SPD disconnecting device should be installed in the top most space available within the panelboard.
 6. Installation of Type 3 SPDs on each critical load is recommended where the level of exposure is high.
 7. Installation of Type 3 SPDs on each non-critical load that is located greater than 3 m (10 ft.) of conductor length from the panelboard is recommended where the level of exposure is high.

FIGURE 7-2 SPD INTERCONNECT BLOCK DIAGRAM 'A'

Block Diagram of AC Power Distribution, SPD and Alarm Circuits with main disconnect located outside the equipment shelter or area and typically at the fence or property line. A separately derived system is utilized.

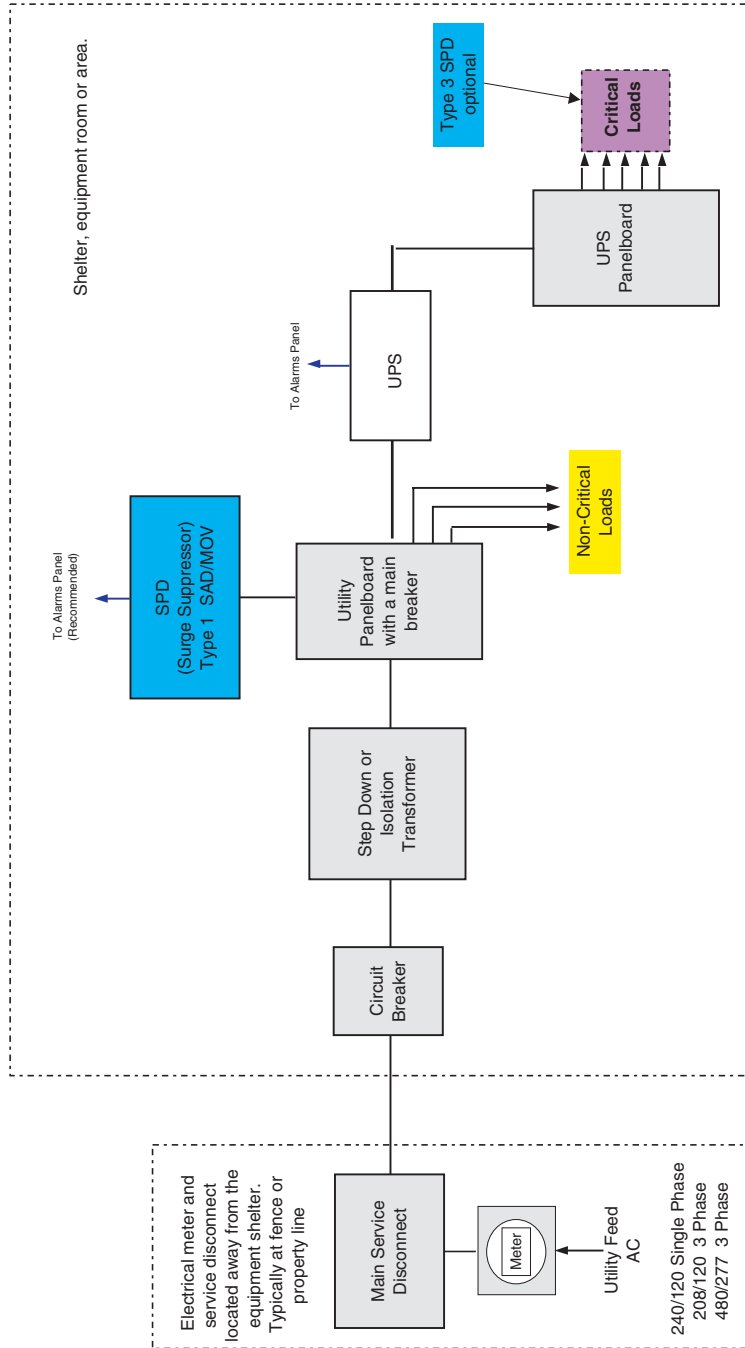

NOTES:

1. The main service disconnect is located outside the equipment shelter, room or area, typically at the fence or property line.
2. The service to the equipment shelter, room or area is 3 conductors with ground for single phase or 4 conductors with ground for 3 phase.
3. The step-down or isolation transformer creates a separately derived system where the neutral and ground conductors are bonded together within the transformer and bonded to the equipment room MGB. The main disconnect ground and the MGB shall be bonded to the site grounding electrode system at the same point.
4. The Utility Panelboard shall use a main disconnecting device to serve the equipment area.
5. The Type 1 SPD shall be installed per the manufacturer's installation instructions.
6. All conductors between the SPD and the associated disconnecting device shall be as short as possible and routed together with a minimal number of bends or angles of less than 90 degrees.
7. The SPD disconnecting device should be installed in the top most space available in the Utility Panelboard.
8. Installation of Type 3 SPDs on each critical load is recommended where the level of exposure is high.
9. Installation of Type 3 SPDs on each non-critical load that is located greater than 3 m (10 ft.) or conductor length from the panelboard is recommended where the level of exposure is high.

FIGURE 7-3 SPD INTERCONNECT BLOCK DIAGRAM 'B'

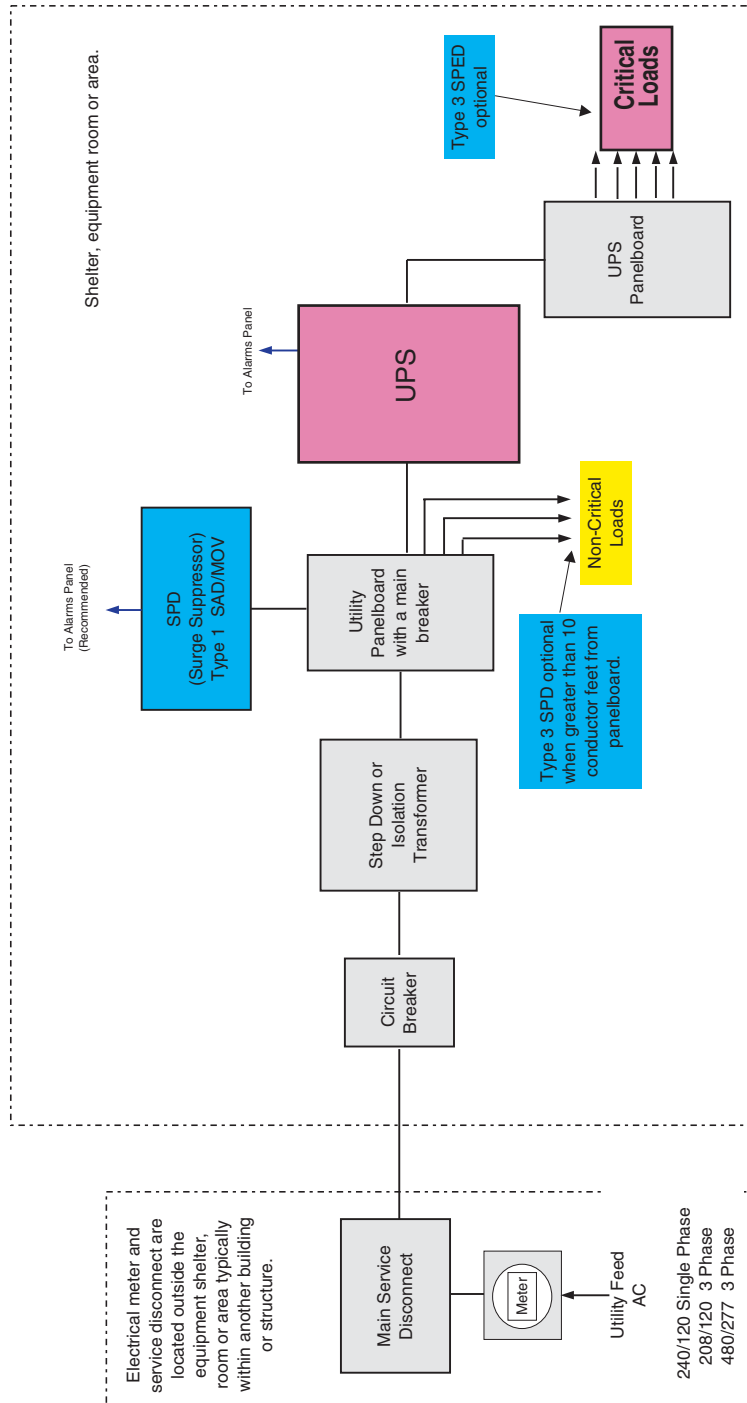

- NOTES:
1. The main service disconnect is located outside the equipment shelter, room or area, typically within another building or structure.
 2. The service to the equipment shelter, room or area is 3 conductors with ground for single phase or 4 conductors with ground for 3 phase.
 3. The step-down or isolation transformer creates a separately derived system where the neutral and ground conductors are bonded together within the transformer and bonded to the equipment room MGB. The main disconnect ground and the MGB shall be bonded to the site grounding electrode system at the same point.
 4. The Utility Panelboard shall use a main disconnecting device to serve the equipment area.
 5. The Type 1 SPD shall be installed per the manufacturer's installation instructions.
 6. All conductors between the SPD and the associated disconnecting device shall be as short as possible and routed together with a minimal number of bends or angles of less than 90 degrees.
 7. The SPD disconnecting device should be installed in the top most space available in the Utility Panelboard.
 8. Installation of Type 3 SPDs on each critical load is recommended where the level of exposure is high.
 9. Installation of Type 3 SPDs on each non-critical load that is located greater than 3 m (10 ft.) of conductor length from the panelboard is recommended where the level of exposure is high.

FIGURE 7-4 SPD INTERCONNECT BLOCK DIAGRAM 'C'

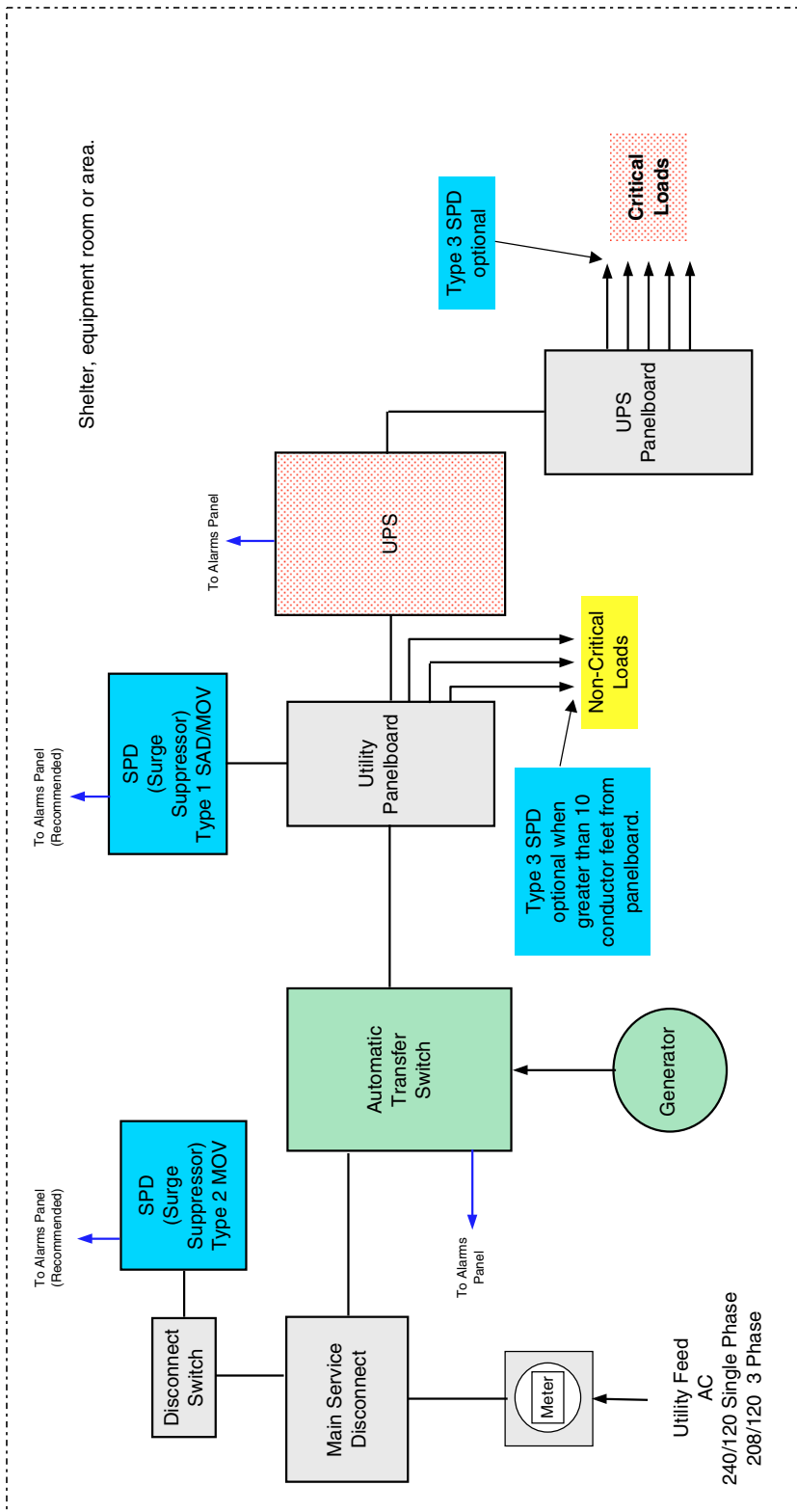
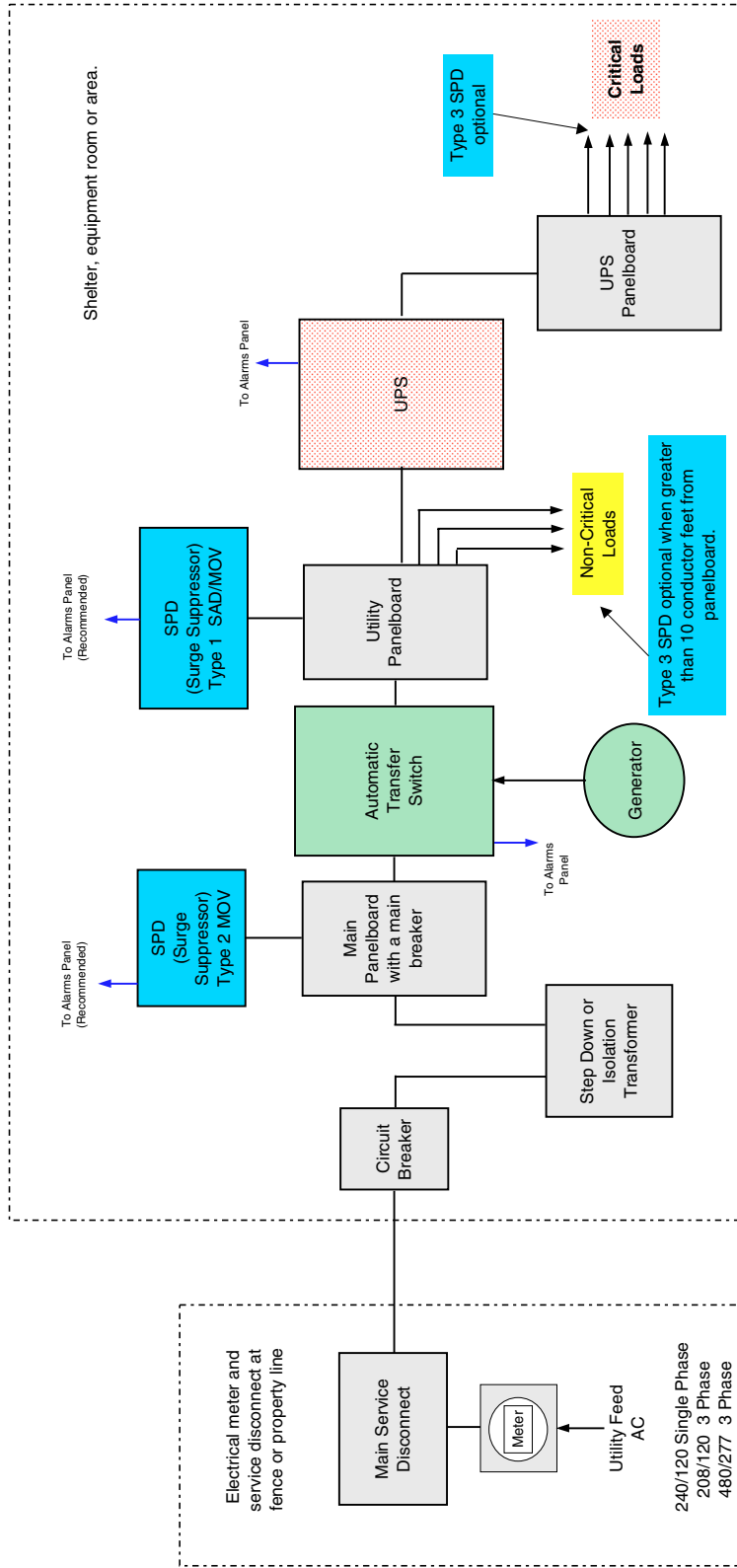

FIGURE 7-5 SPD INTERCONNECT BLOCK DIAGRAM 'D'

- NOTES:
1. All electrical panelboards shown are collocated within the shelter, room or equipment area.
 2. The SPDs shall be installed per the manufacturer's installation instructions.
 3. All conductors between the SPD and the associated disconnecting devices shall be as short as possible and routed together with a minimal number of bends or angles.
 4. The SPD disconnecting device in the Utility Panelboard should be installed in the top most space available.
 5. Installation of Type 3 SPDs on each critical load is recommended where the level of exposure is high.
 6. Installation of Type 3 SPDs on each non-critical load that is located greater than 3 m (10 ft.) of conductor length from the panelboard is recommended where the level of exposure is high.



- NOTES:
1. The main service disconnect is located outside the equipment shelter, room or area, typically at the fence or property line.
 2. The service to the equipment shelter, room or area is 3 conductors with ground for single phase or 4
 3. The step-down or isolation transformer creates a separately derived system where the neutral and ground conductors are bonded together within the transformer and bonded to the equipment room MGB. The main disconnect ground and the MGB shall be bonded to the site grounding electrode system.
 4. The Main panelboard shall use a main disconnecting device to serve the equipment area.
 5. The Type 1 and Type 2 SPDs shall be installed per the manufacturer's installation instructions.
 6. All conductors between the SPDs and the associated disconnecting device shall be as short as possible and routed together with a minimal number of bends or angles of less than 90 degrees.
 7. The SPD disconnecting devices should be installed in the top most space available in the Utility Panelboard.
 8. Installation of Type 3 SPDs on each critical load are recommended at locations with high lightning activity.
 9. Installation of Type 3 SPDs on each non-critical load that is located greater than 3 m (10 ft.) of conductor length from the panelboard is recommended at locations with high lightning activity.

FIGURE 7-6 SPD INTERCONNECT BLOCK DIAGRAM 'E'

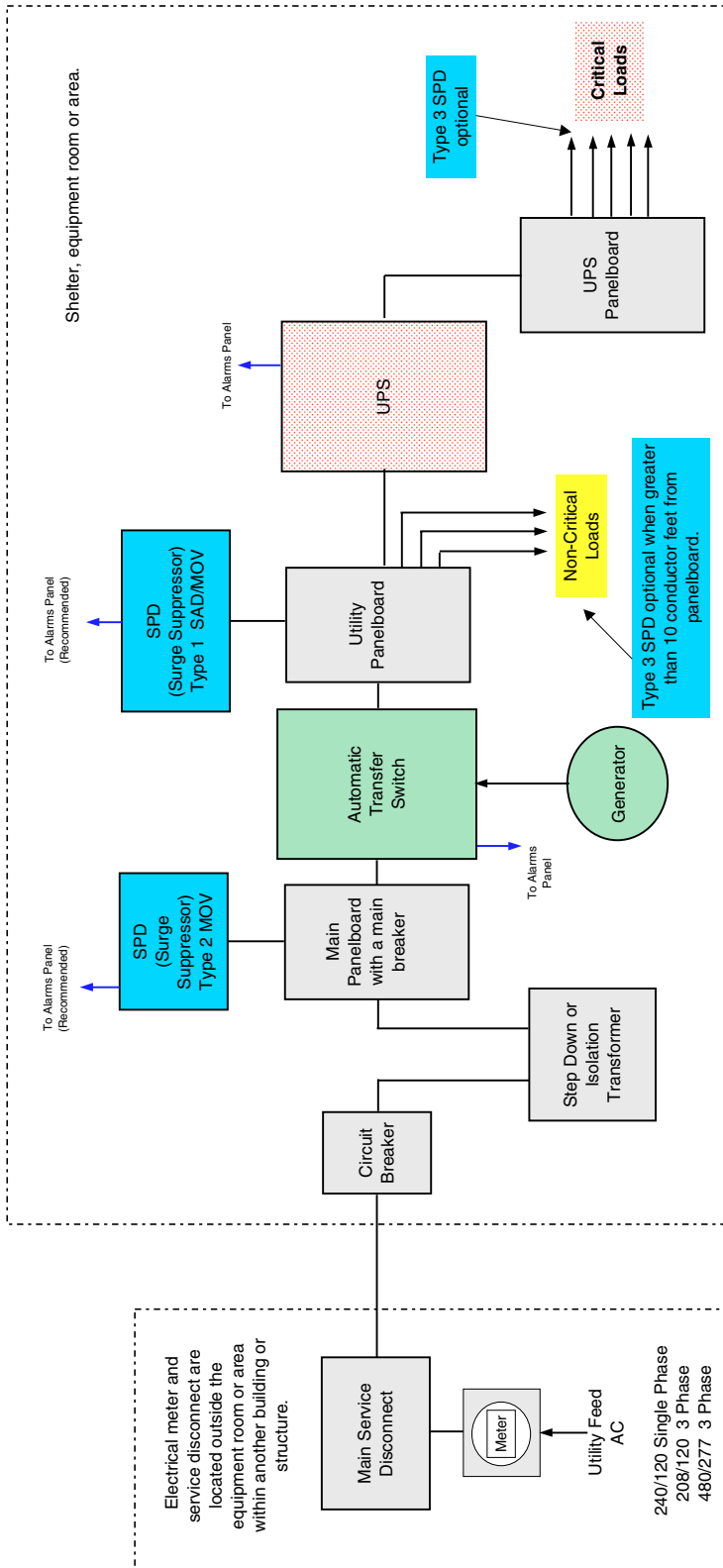

- NOTES:**
1. The main service disconnect is located outside the equipment shelter, room or area, typically within another building or structure.
 2. The service to the equipment shelter, room or area is 3 conductors with ground for single phase or 4 conductors with ground for 3 phase.
 3. The step-down or isolation transformer creates a separately derived system where the neutral and ground conductors are bonded together within the transformer and bonded to the equipment room MGB. The main disconnect ground and the MGB shall be bonded to the site grounding electrode system.
 4. The Main panelboard shall use a main disconnecting device to serve the equipment area.
 5. The Type 1 and Type 2 SPDs shall be installed per the manufacturer's installation instructions.
 6. All conductors between the SPDs and the associated disconnecting device shall be as short as possible and routed together with a minimal number of bends or angles of less than 90 degrees.
 7. The SPD disconnecting devices should be installed in the top most space available in the Utility Panelboard.
 8. Installation of Type 3 SPDs on each critical load is recommended where the level of exposure is high.
 9. Installation of Type 3 SPDs on each non-critical load that is located greater than 3 m (10 ft.) of conductor length from the panelboard is recommended where the level of exposure is high.

FIGURE 7-7 SPD INTERCONNECT BLOCK DIAGRAM 'F'

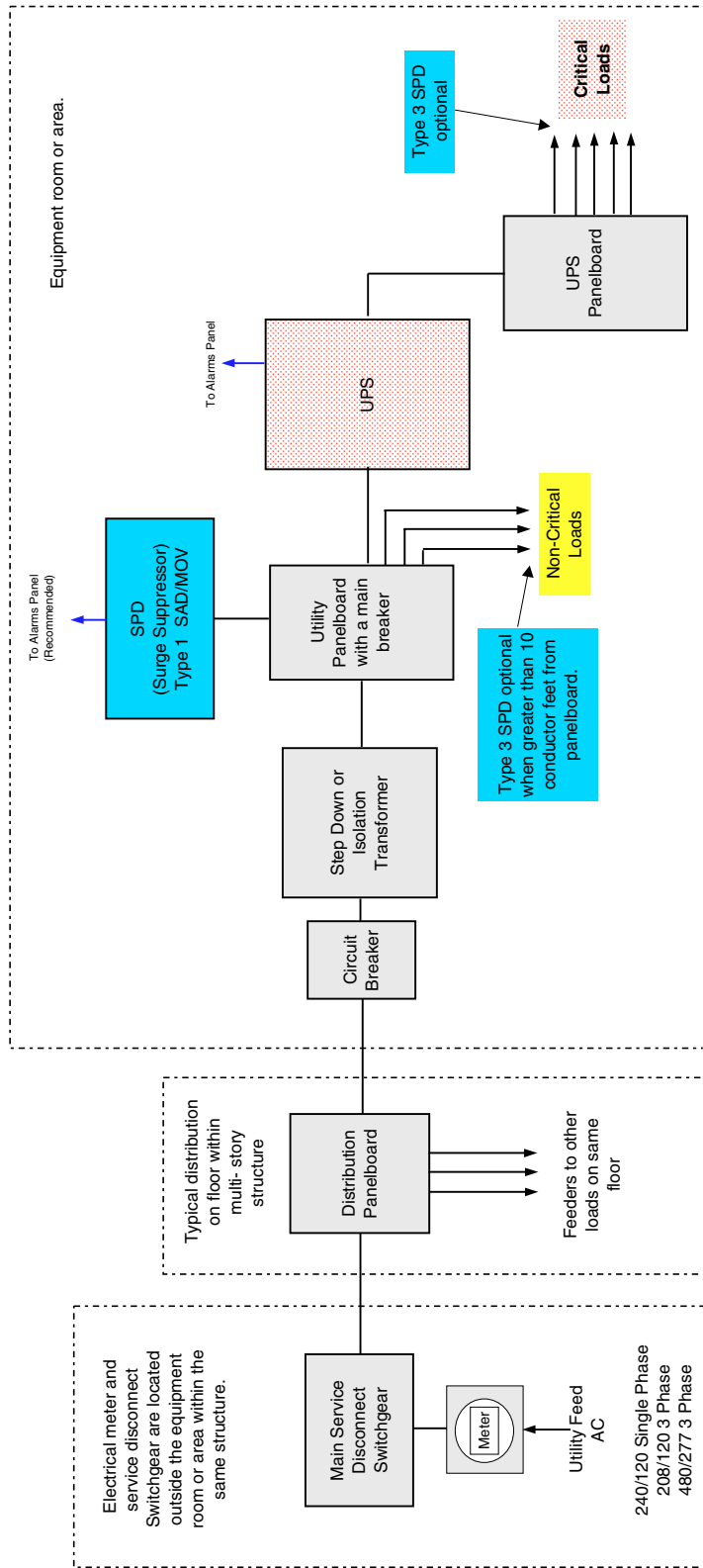

NOTES:

1. The main service disconnect is located outside the equipment room or area within the same structure. Additional distribution panelboards may be located within the structure, typically one per floor.
2. The service to the equipment room or area is 3 conductors with ground for single phase or 4 conductors with ground for 3 phase.
3. The step-down or isolation transformer creates a separately derived system where the neutral and ground conductors are bonded together within the transformer and bonded to the equipment room MGB. The main disconnect ground and the MGB shall be bonded to the site grounding electrode system at the same point.
4. The Utility panelboard shall use a main disconnecting device to serve the equipment area.
5. The Type 1 SPD shall be installed per the manufacturer's installation instructions.
6. All conductors between the SPD and the associated disconnecting device shall be as short as possible and routed together with a minimal number of bends or angles of less than 90 degrees.
7. The SPD disconnecting device should be installed in the topmost space available in the Utility Panelboard.
8. Installation of Type 3 SPDs on each critical load is recommended where the level of exposure is high.
9. Installation of Type 3 SPDs on each non-critical load that is located greater than 3 m (10 ft.) of conductor length from the panelboard is recommended where the level of exposure is high.

FIGURE 7-8 SPD INTERCONNECT BLOCK DIAGRAM 'G'

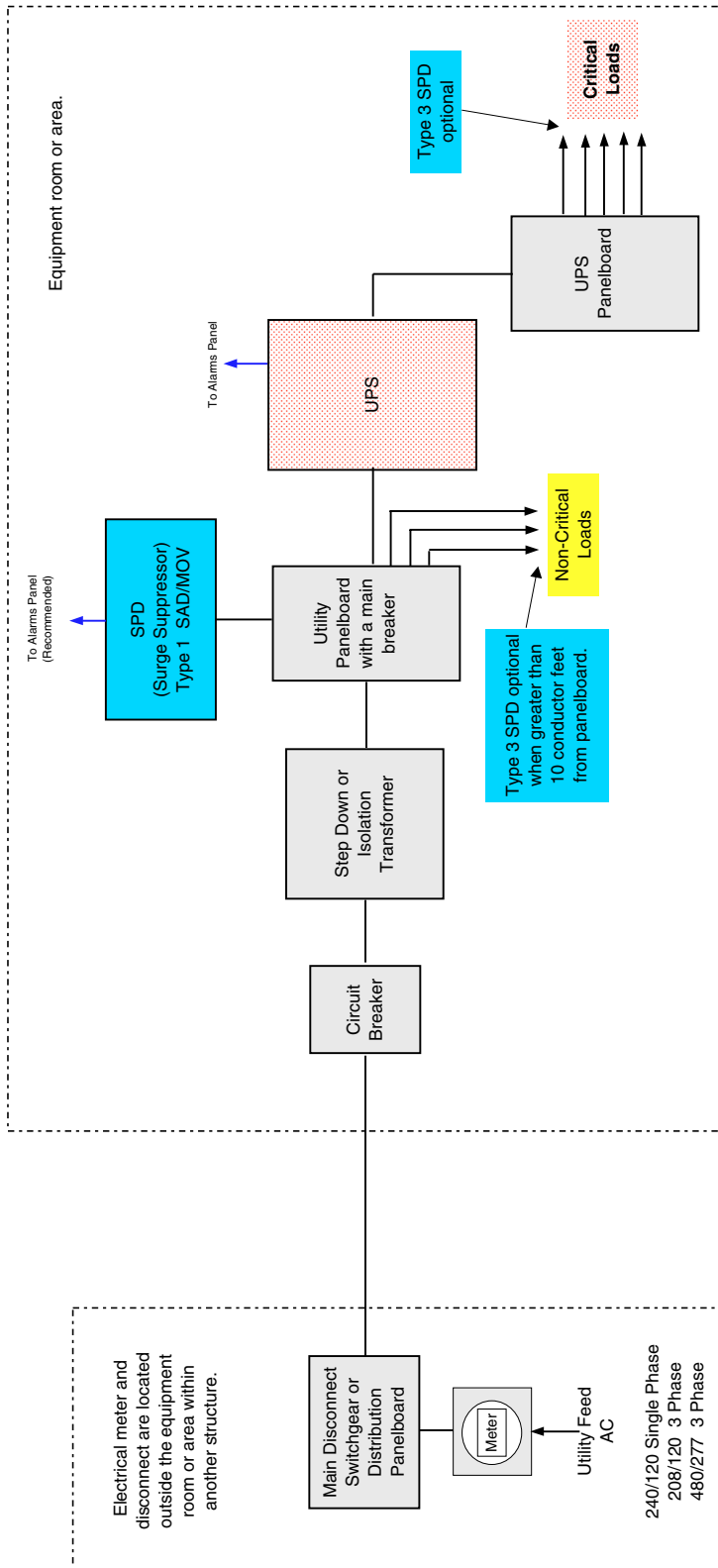

- NOTES:
1. The main service disconnect is located outside the equipment room or area within another structure.
 2. The service to the equipment room or area is 3 conductors with ground for single phase or 4 conductors with ground for 3 phase.
 3. The step-down or isolation transformer creates a separately derived system where the neutral and ground conductors are bonded together within the transformer and bonded to the equipment room MGB. The main disconnect ground and the MGB shall be bonded to the site grounding electrode system at the same point.
 4. The Utility panelboard shall use a main disconnecting device to serve the equipment area.
 5. The Type 1 SPD shall be installed per the manufacturer's installation instructions.
 6. All conductors between the SPD and the associated disconnecting device shall be as short as possible and routed together with a minimal number of bends or angles of less than 90 degrees.
 7. The SPD disconnecting device should be installed in the topmost space available in the Utility Panelboard.
 8. Installation of Type 3 SPDs on each critical load is recommended where the level of exposure is high.
 9. Installation of Type 3 SPDs on each non-critical load that is located greater than 3 m (10 ft.) of conductor length from the panelboard is recommended where the level of exposure is high.

FIGURE 7-9 SPD INTERCONNECT BLOCK DIAGRAM 'H'

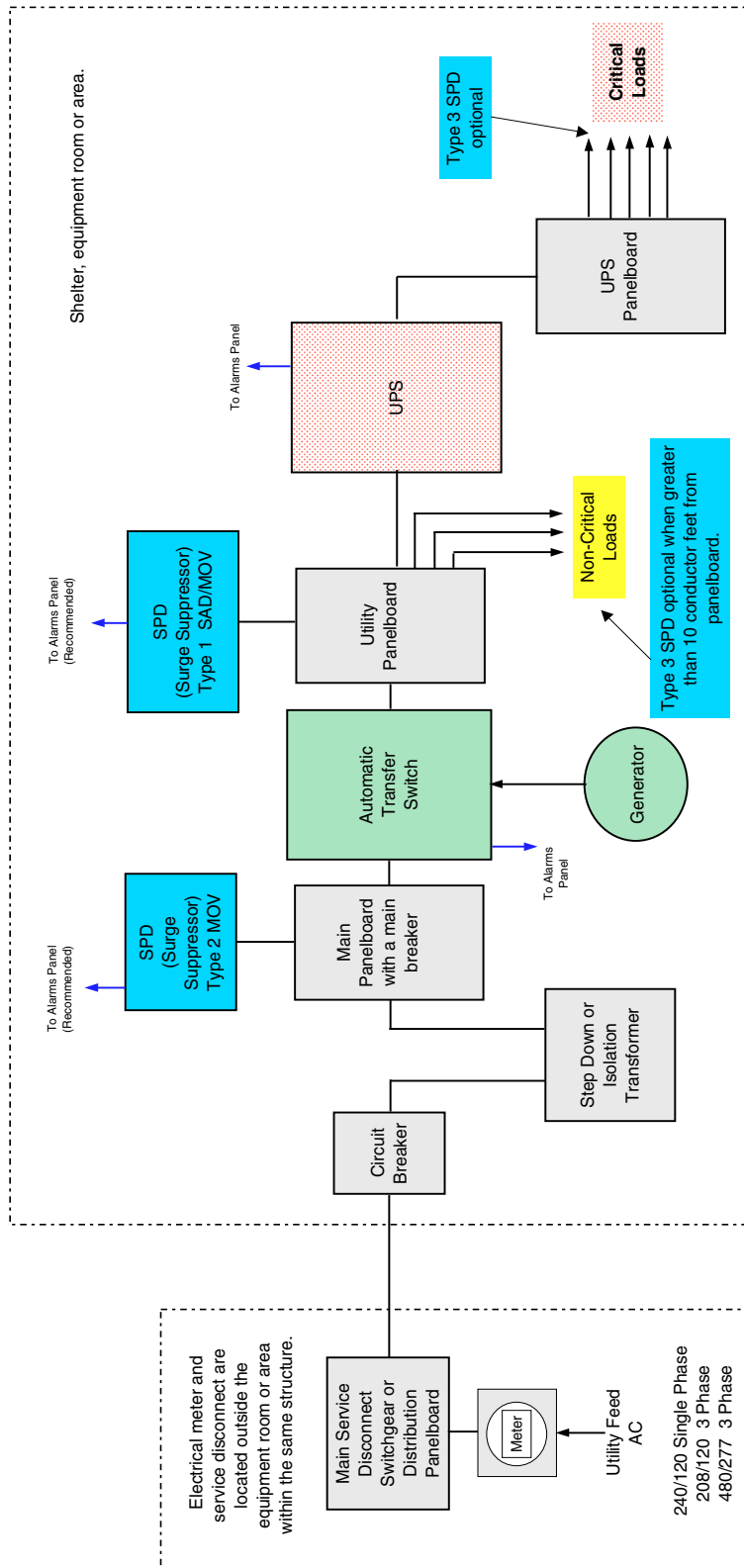

- NOTES:
1. The main service disconnect is located outside the equipment shelter, room or area, typically within the same building or structure. Additional distribution panelboards may be located within the structure, but are not shown.
 2. The service to the equipment shelter, room or area is 3 conductors with ground for single phase or 4 conductors with ground for 3 phase.
 3. The step-down or isolation transformer creates a separately derived system where the neutral and ground conductors are bonded together within the transformer and bonded to the equipment room MGB. The main disconnect ground and the MGB shall be bonded to the site grounding electrode system.
 4. The Main panelboard shall use a main disconnecting device to serve the equipment area.
 5. The Type 1 and Type 2 SPDs shall be installed per the manufacturer's installation instructions.
 6. All conductors between the SPDs and the associated disconnecting device shall be as short as possible and routed together with a minimal number of bends or angles of less than 90 degrees.
 7. The SPD disconnecting devices should be installed in the top most space available in the Utility Panelboard.
 8. Installation of Type 3 SPDs on each critical load is recommended where the level of exposure is high.
 9. Installation of Type 3 SPDs on each non-critical load that is located greater than 3 m (10 ft.) of conductor length from the panelboard is recommended where the level of exposure is high.

FIGURE 7-10 SPD INTERCONNECT BLOCK DIAGRAM 'I'

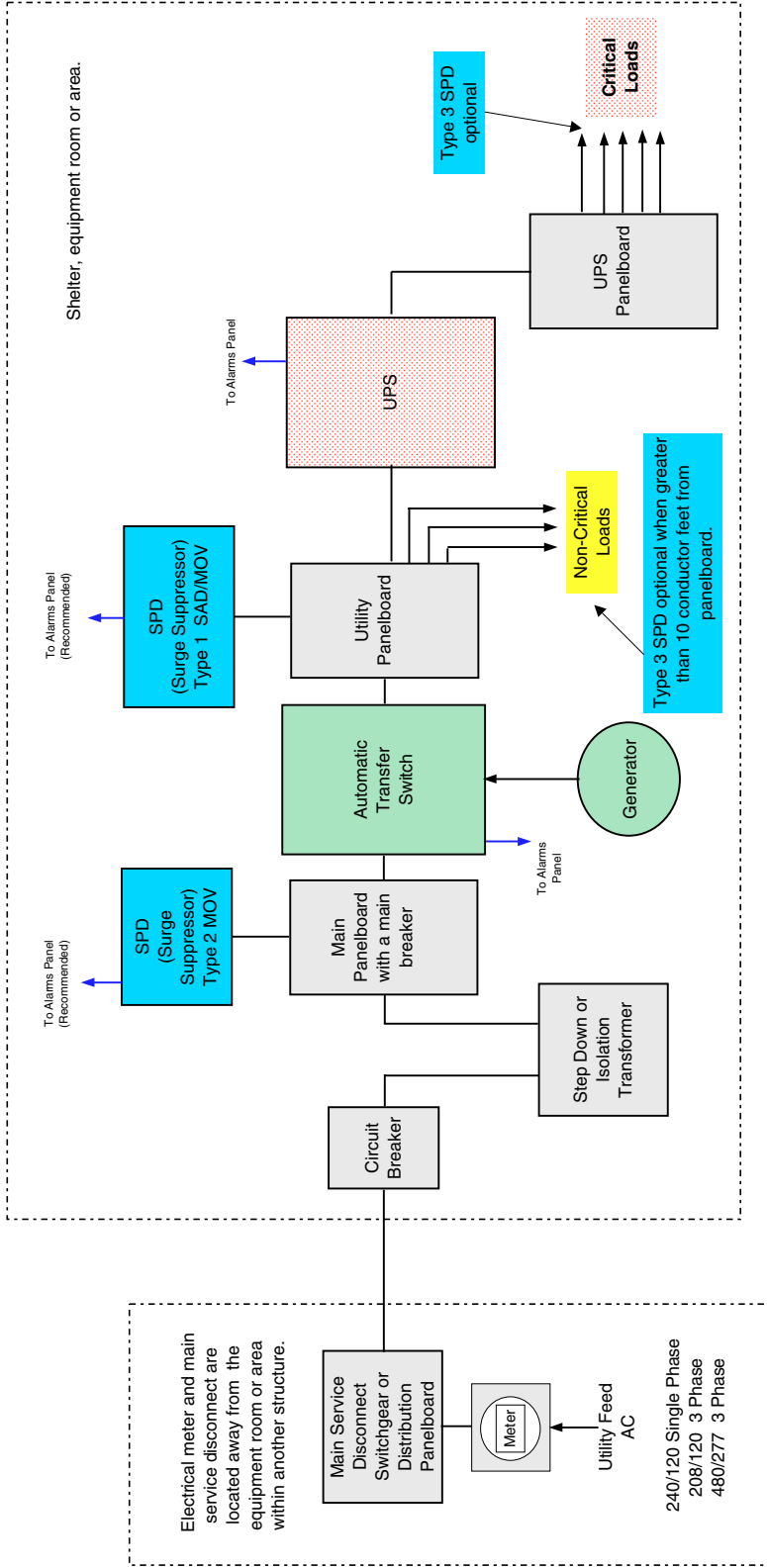

- NOTES:**
1. The main service disconnect is located away from the equipment shelter, room or area, typically within another building or structure.
 2. The service to the equipment shelter, room or area is 3 conductors with ground for single phase or 4 conductors with ground for 3 phase.
 3. The step-down or isolation transformer creates a separately derived system where the neutral and ground conductors are bonded together within the transformer and bonded to the equipment room MGB. The main disconnect ground and the MGB shall be bonded to the site grounding electrode system.
 4. The Main panelboard shall use a main disconnecting device to serve the equipment area.
 5. The Type 1 and Type 2 SPDs shall be installed per the manufacturers installation instructions.
 6. All conductors between the SPDs and the associated disconnecting device shall be as short as possible and routed together with a minimal number of bends or angles of less than 90 degrees.
 7. The SPD disconnecting devices should be installed in the top most space available in the Utility Panelboard.
 8. Installation of Type 3 SPDs on each critical load is recommended where the level of exposure is high.
 9. Installation of Type 3 SPDs on each non-critical load that is located greater than 3 m (10 ft.) of conductor length from the panelboard is recommended where the level of exposure is high.

FIGURE 7-11 SPD INTERCONNECT BLOCK DIAGRAM 'J'

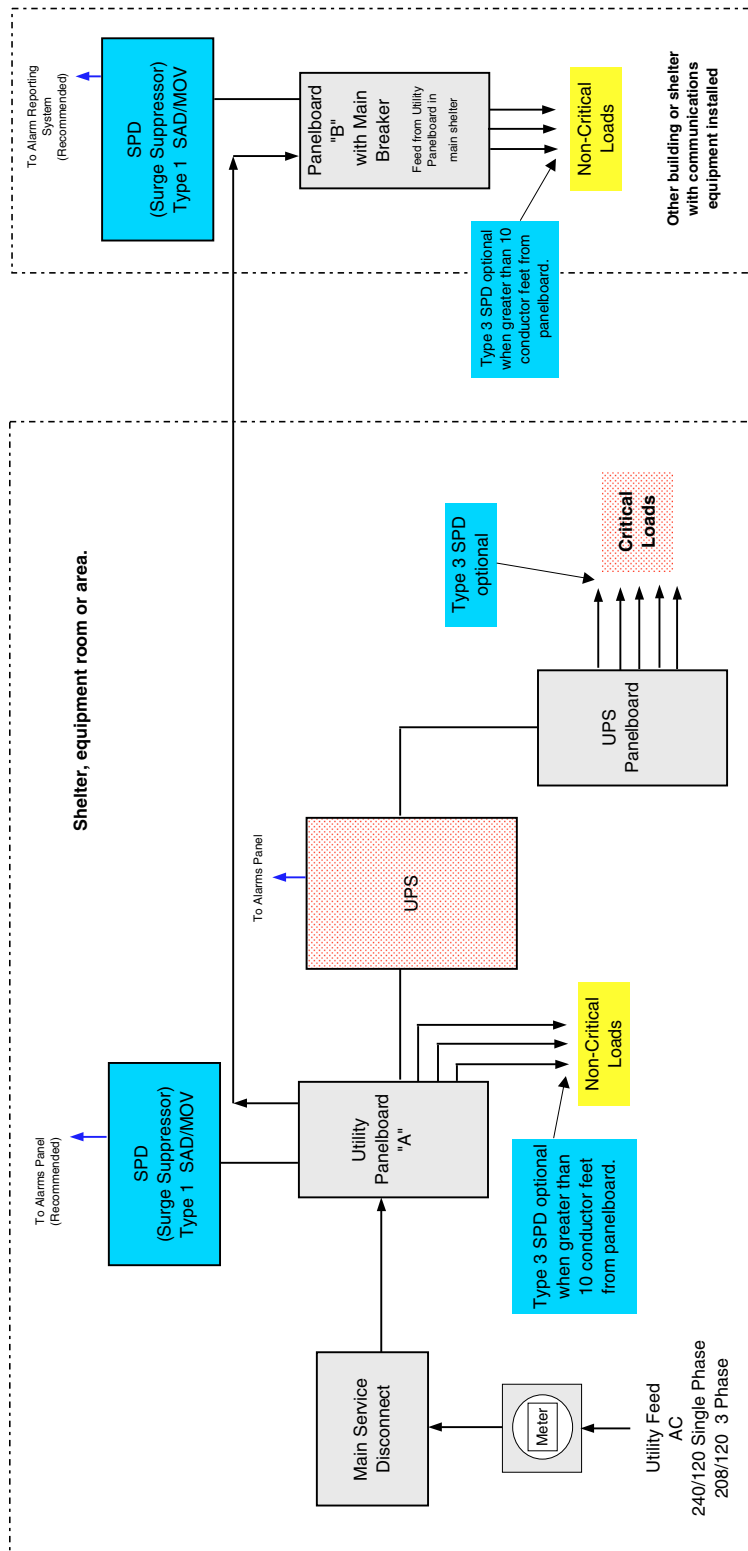

- NOTES:
1. The main service disconnect may be an integral part of the Utility Panelboard.
 2. The feeder to the adjacent shelter is 3 conductors with ground for single phase or 4 conductors with ground for 3 phase.
 3. No critical loads should be placed within the adjacent shelter or building unless a separately derived system is installed within the adjacent shelter. This could be in the form of a transformer or a suitable UPS system.
 4. The main service disconnect and utility panelboard "A" are collocated within the equipment area. Panelboard "B" is located within another adjacent shelter or building.
 5. The SPDs shall be installed per the manufacturers installation instructions.
 6. All conductors between the SPDs and the associated disconnecting device shall be as short as possible and routed together with a minimal number of bends or angles of less than 90 degrees.
 7. The SPD disconnecting device should be installed in the top-most space available within panelboards "A" and "B."
 8. Installation of Type 3 SPDs on each critical load is recommended where the level of exposure is high.
 9. Installation of Type 3 SPDs on each non-critical load that is located greater than 3m (10 ft.) of conductor length from the panelboard is recommended where the level of exposure is high.

FIGURE 7-12 SPD INTERCONNECT BLOCK DIAGRAM 'K'

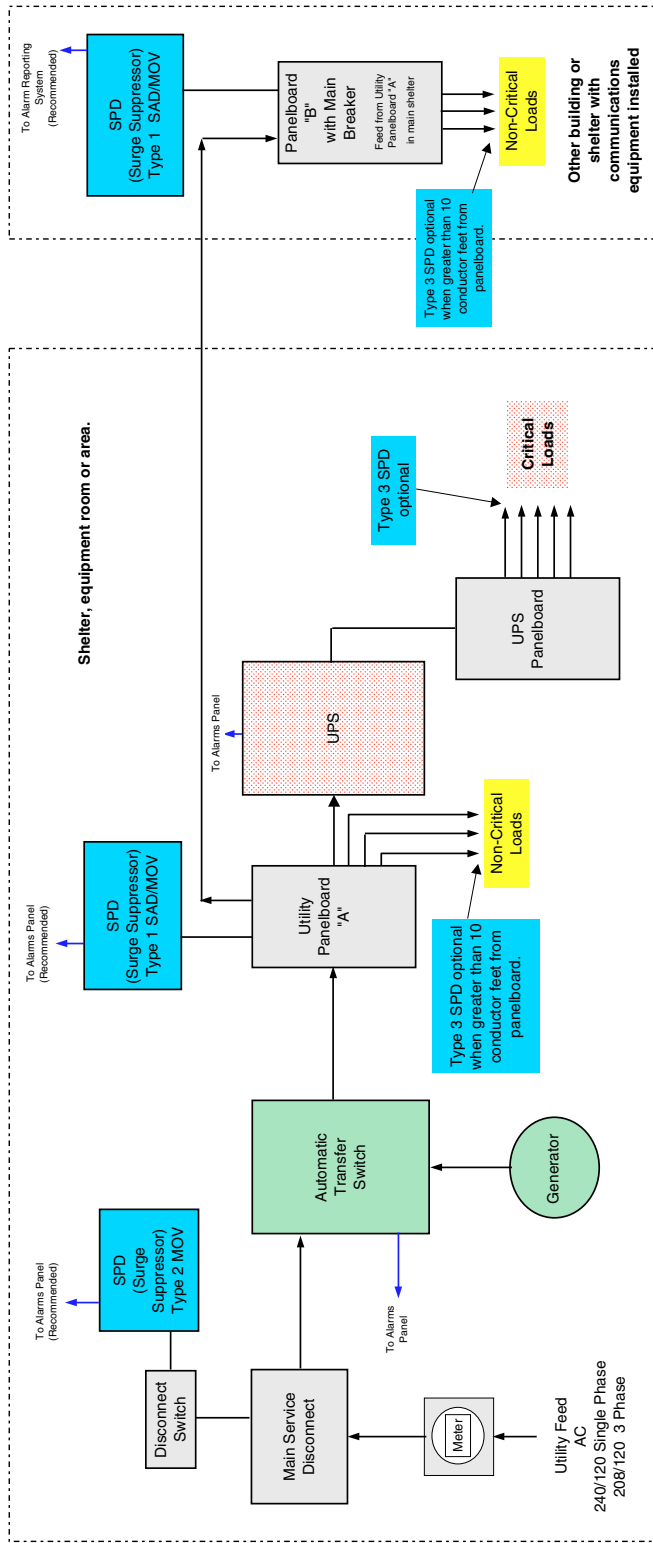

- NOTES:
1. The feeder to the adjacent shelter is 3 conductors with ground for single phase or 4 conductors with ground for 3 phase.
 2. No critical loads should be placed within the adjacent shelter or building unless a separately derived system is installed within the adjacent shelter. This could be in the form of a transformer or a suitable UPS system.
 3. The main service disconnect, Automatic Transfer Switch and utility panelboard "A" are collocated within the equipment area. Panelboard "B" is located within another adjacent shelter or building.
 4. The SPDs shall be installed per the manufacturers installation instructions.
 5. All conductors between the SPD and the associated disconnecting devices shall be as short as possible and routed together with a minimal number of bends or angles.
 6. The SPD disconnecting devices should be installed in the top most space available in Panelboards "A" & "B".
 7. Installation of Type 3 SPDs on each critical load is recommended where the level of exposure is high.
 8. Installation of Type 3 SPDs on each non-critical load that is located greater than 3 m (10 ft.) of conductor length from the panelboard is recommended where the level of exposure is high.

FIGURE 7-13 SPD INTERCONNECT BLOCK DIAGRAM 'L'

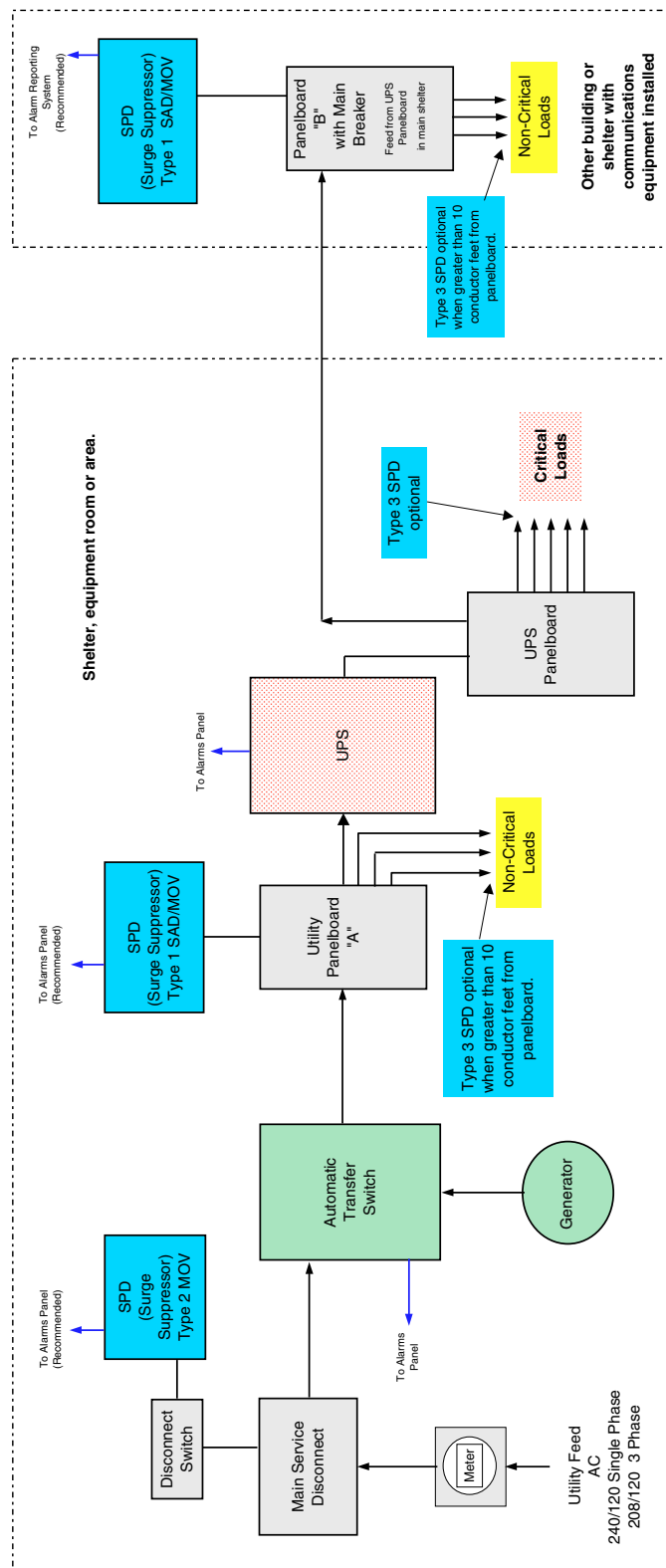

- NOTES:
1. The feeder to the adjacent shelter is 3 conductors with ground for single phase or 4 conductors with ground for 3 phase.
 2. No critical loads should be placed within the adjacent shelter or building unless a separately derived system is installed within the adjacent shelter. This could be in the form of a transformer or suitable UPS system.
 3. The main service disconnect, Automatic Transfer Switch and utility panelboard "A" are collocated within the equipment area. Panelboard "B" is located within another adjacent shelter or building.
 4. The SPDs shall be installed per the manufacturer's installation instructions.
 5. All conductors between the SPD and the associated disconnecting devices shall be as short as possible and routed together with a minimal number of bends or angles.
 6. The SPD disconnecting devices should be installed in the top most space available in Panelboards "A" & "B".
 7. Installation of Type 3 SPDs on each critical load is recommended where the level of exposure is high.
 8. Installation of Type 3 SPDs on each non-critical load that is located greater than 3 m (10 ft.) or conductor length from the panelboard is recommended where the level of exposure is high.

FIGURE 7-14 SPD INTERCONNECT BLOCK DIAGRAM 'M'

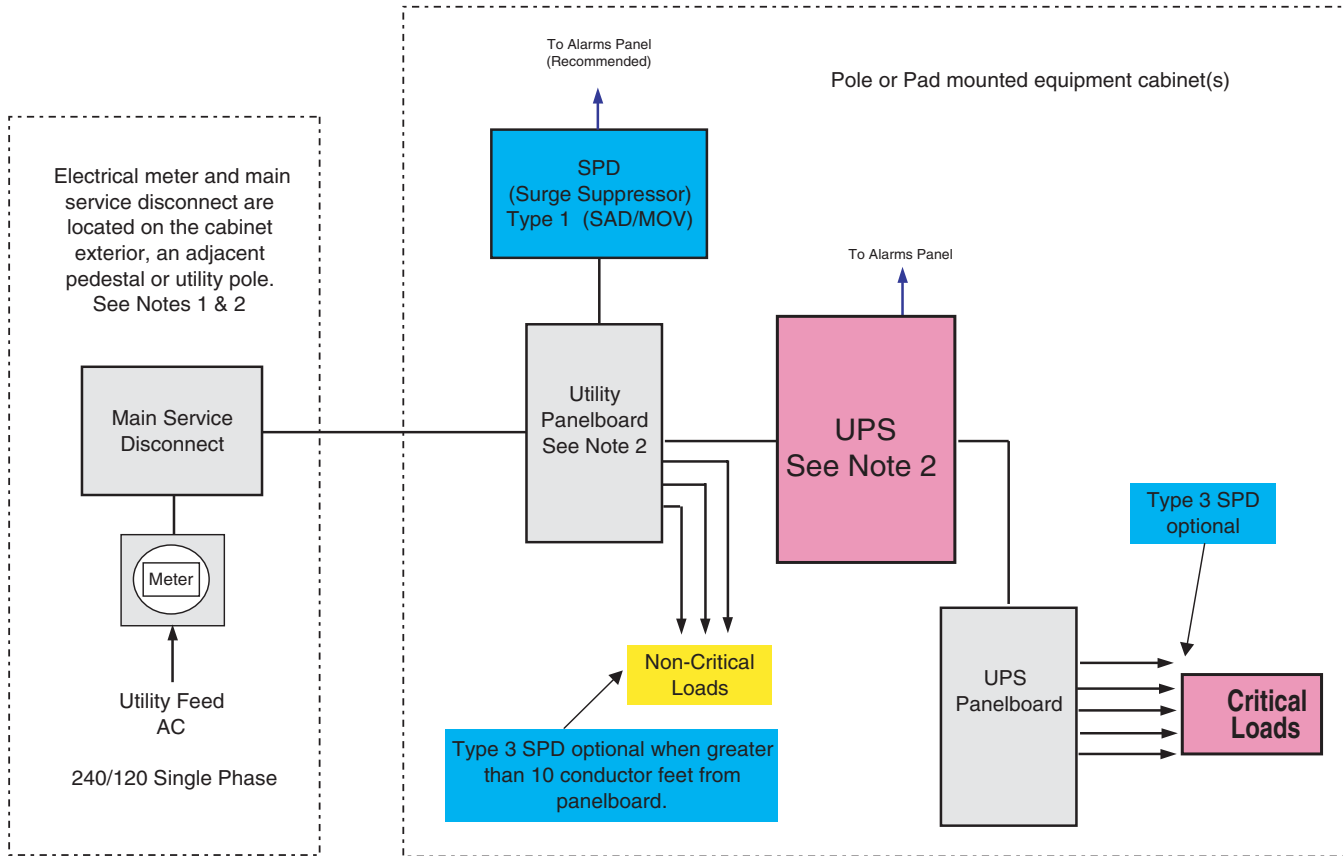

- NOTES:
1. The main service disconnect may be located outside the pole or pad mounted equipment cabinet, typically on the cabinet exterior, an adjacent pedestal or utility pole.
 2. The main service disconnect may be an integral part of the Utility Panelboard.
 3. The UPS may not be present in which case all loads will be fed from the Utility Panelboard
 4. The Type 1 SPD shall be installed per the manufacturer's installation instructions.
 5. All conductors between the SPD and the associated disconnecting device shall be as short as possible and routed together with a minimal number of bends or angles of less than 90 degrees.
 6. The SPD disconnecting device should be installed in the top most space available in the Utility Panelboard.
 7. Installation of Type 3 SPDs on critical and non critical loads, although optional, is recommended where the level of exposure is high.

FIGURE 7-15 SPD INTERCONNECT BLOCK DIAGRAM 'N'

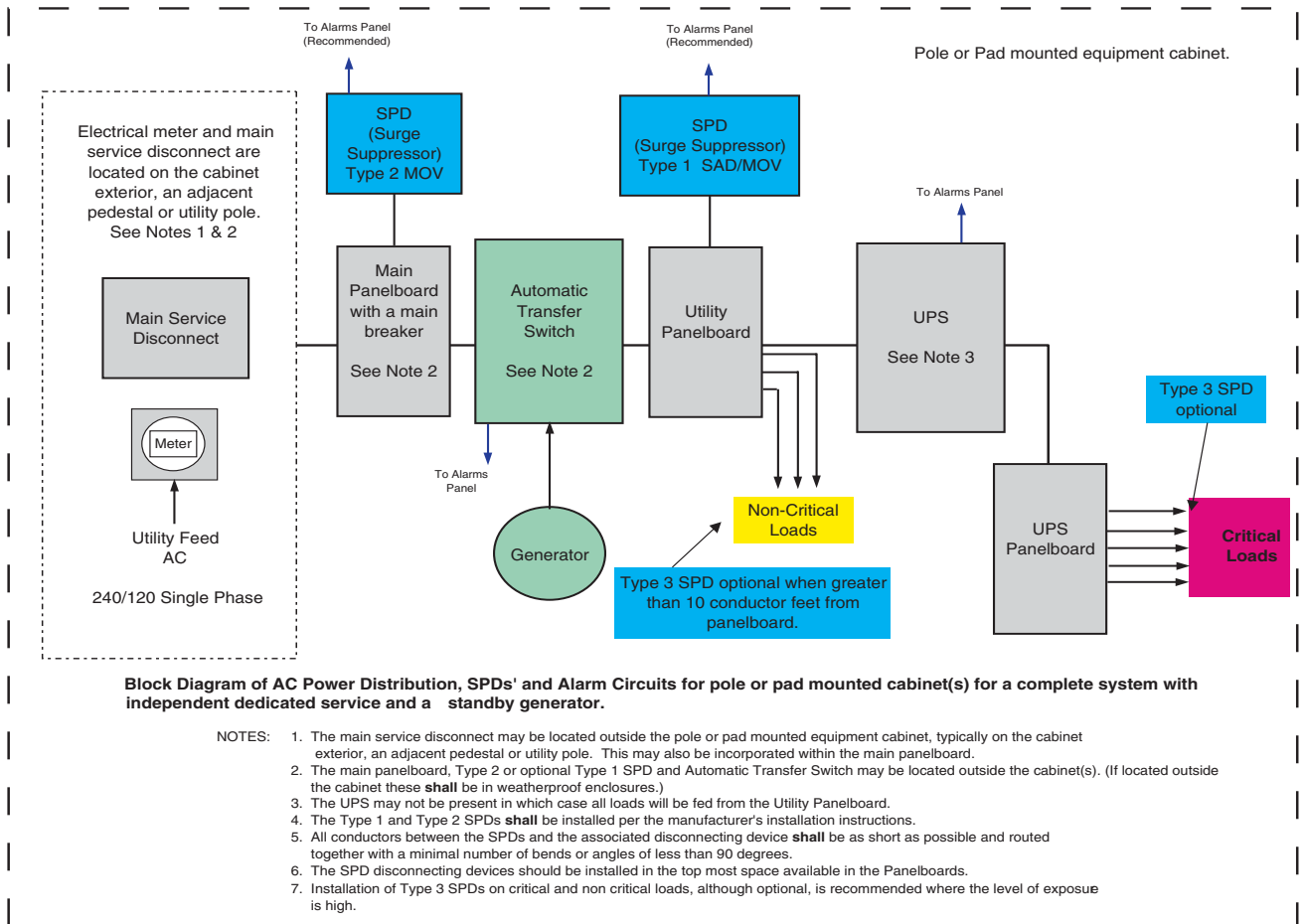
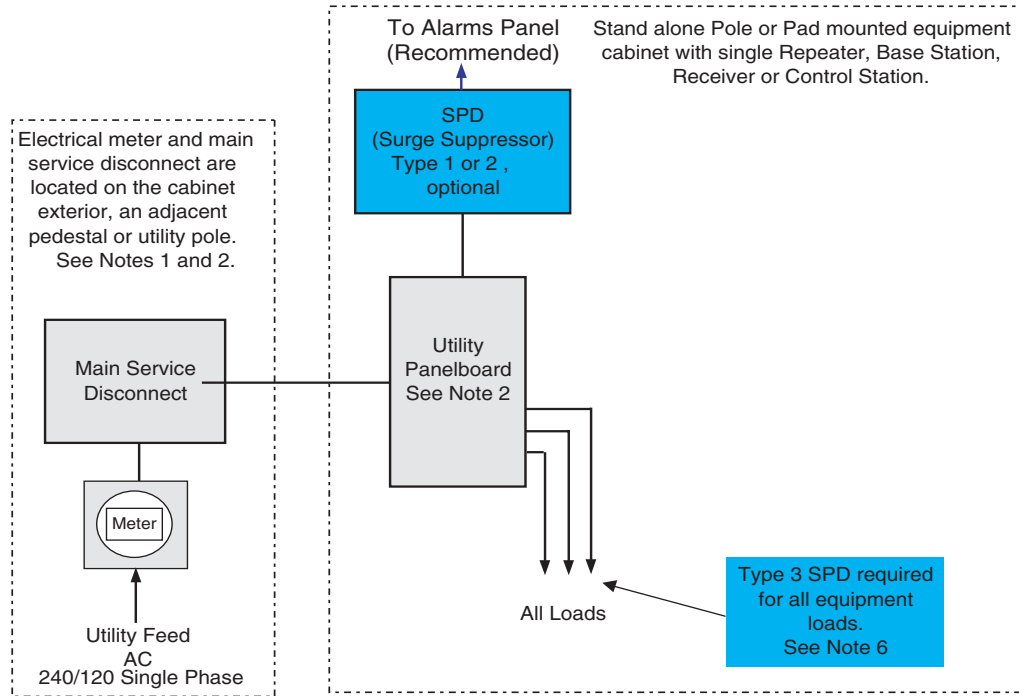
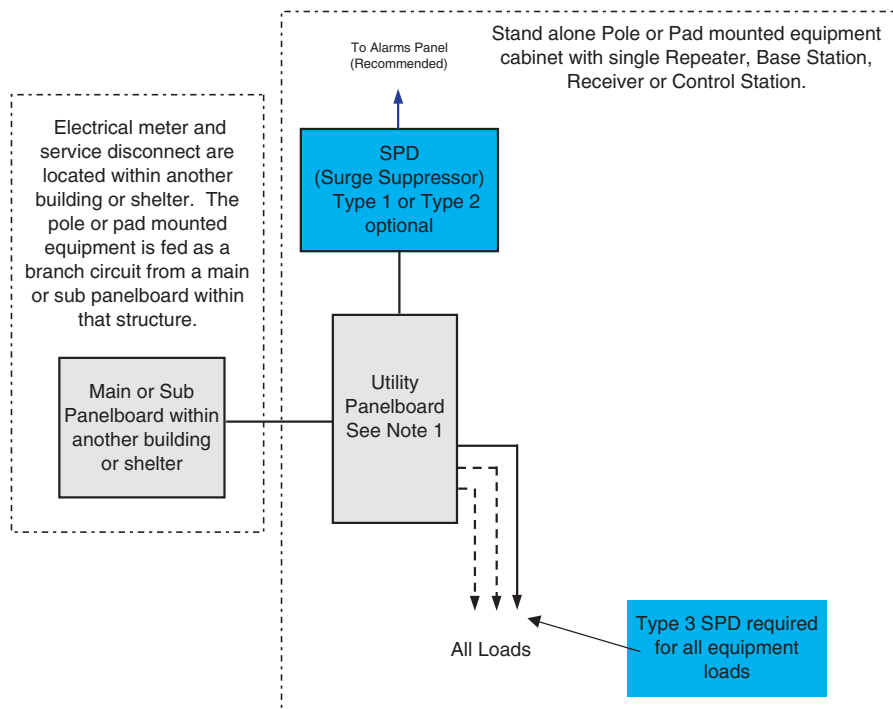

FIGURE 7-16 SPD INTERCONNECT BLOCK DIAGRAM 'O'



- NOTES:**
1. The main service disconnect may be located outside the equipment pole or pad mounted cabinet, typically on the cabinet exterior, an adjacent pedestal or utility pole.
 2. The Main service disconnect may be a part of the Utility Panelboard.
 3. When installed the Type 1 or Type 2 SPD **shall** be installed per the manufacturer's installation instructions.
 4. All conductors between the SPD and the associated disconnecting device **shall** be as short as possible and routed together with a minimal number of bends or angles of less than 90 degrees.
 5. The SPD disconnecting devices should be installed in the top most space available in the Utility Panelboard.
 6. Installation of Type 3 SPDs on each load is required unless a Type 1 SPD is installed on the Utility Panelboard.

FIGURE 7-17 SPD INTERCONNECT BLOCK DIAGRAM 'P'



- NOTES:**
1. A disconnecting device is required within the pole or pad mounted cabinet. This may be a single disconnect if no Type 1 or Type 2 SPD is installed and there is only one load.
 2. When installed the Type 1 or Type 2 SPDs **shall** be installed per the manufacturer's installation instructions.
 3. All conductors between the SPDs and the associated disconnecting device **shall** be as short as possible and routed together with a minimal number of bends or angles of less than 90 degrees.
 4. The SPD disconnecting devices should be installed in the topmost space available in the Utility Panelboard.
 5. Installation of Type 3 SPDs on each load is required unless a Type 1 SPD is installed on the Utility Panelboard.

FIGURE 7-18 SPD INTERCONNECT BLOCK DIAGRAM 'Q'

7.4.2 SPD TYPES

SPDs used for AC power protection referenced in this section are defined as Type 1, Type 2, or Type 3 and are defined below.

Table 7-4 on page 7-32 lists required specifications for various SPDs.

7.4.2.1 TYPE 1 PANEL TYPE SURGE SUPPRESSION DEVICE

Type 1 SPD provides protection for the service entrance, and all branch panel locations within the same equipment room. The requirements are as follows:

- The device **shall** consist of primary modules using SAD technology and secondary modules using MOV technology.
- The SPD **shall** be a permanently connected, one-port, or parallel configuration
- The suppression components **shall** be voltage limiting type. Voltage switching components **shall not** be utilized as a suppression element in the SPD.
- All suppression modules **shall** be installed from each phase conductor to the neutral conductor (L-N, Normal Mode).

- Suppression modules or devices of any type **shall not** be connected between any phase conductor and the equipment grounding conductor or ground (L-G, Common Mode Neutral to Ground).
- The primary module(s) **shall** consist of a SAD module(s) providing 20KA per phase, per polarity, minimum energy absorption.
- The secondary module(s) **shall** consist of a Metal Oxide Varistor (MOV) module(s), with sufficient energy handling capability to meet the maximum discharge current requirement of 160 kA per mode.
- The minimum pulse life or durability requirements and the voltage protection level **shall** be as specified in Table 7-4 for the respective Maximum Continuous Operating Voltage (MCOV) listed.
- SPD **shall** be properly selected based on the operating voltage and number of phases of the circuits to be protected.
- Each module or subassembly **shall** be modular in design to allow for easy field replacement.
- The SPD **shall** use integral over-current protective devices, and the SPD **shall** have a short circuit current rating of 25,000 amperes, as defined by UL 1449, second edition, Section 39.
- The SPD **shall** have a nominal discharge current of 10,000 amperes, as defined, and tested by IEEE IEEE C62.45-2002 waveform characteristics (Category C high 10 kA 6kV minimum) SPD tested in accordance with IEEE C62.45-2002.
- The SPD **shall** have a voltage protection level (at the nominal discharge current of 10,000 amperes) of 600 Vpk or less from each phase-to-neutral mode, when tested in accordance with IEEE C62.45-2002. Test points are measured using specified conductor size at a distance of 150 mm (6 in.) outside of the enclosure.
- The SPD **shall** have a Suppressed Voltage Rating (SVR) of 330 Vpk, as determined by testing in accordance with UL 1449, second edition, Section 34.
- The SPD **shall** have a maximum discharge current of 160 kA per mode, as tested in accordance with IEC 61643-1
- The enclosure rating of the SPD **shall** be NEMA 4. The maximum dimensions of the enclosure **shall** be 406 mm × 406 mm × 228 mm (16 in. × 16 in. × 9 in.) for single-phase, 3W+G configurations, and 508 mm × 508 mm × 228 mm (20 in. × 20 in. × 9 in.) for three-phase wye, 4W+G configurations. The maximum weight of the SPD **shall** be 13.6 kg (30 lb), and 18 kg (40 lb) respectively.
- The environmental parameters of the SPD are as follows:
 - Operating temperature range: -40 °C to +65 °C
 - Storage temperature range: -40 °C to +65 °C
 - Operating humidity range: 0-95%, non-condensing
 - Altitude range: -152.4 m to 4572 m (-500 ft to +15,000 ft.)
- Connection to the SPD **shall** be conducted with a wire range of 16 mm² csa (#6 AWG) or coarser. Per NFPA 70-2005, Article 110, the conductor size **shall** match the breaker size.
- Each SPD **shall** have indicator lamps on or visible from the front of the device showing that power is applied and that the protection integrity has not been compromised.

- The SPD **shall** include a set of form “C” dry contacts, rated at a minimum of 250 VAC, and a minimum of 2.0 amperes, with a power factor of 1.0, for remote alarm reporting capability. This set of contacts **shall** operate when there is an input power failure or the integrity of any module has been compromised. This contact set **shall** be isolated from the AC power circuitry to safeguard the alarm circuit or reporting device should there be a catastrophic event. Connection to the remote monitoring contacts of the SPD **shall** utilize 0.34 mm² (#22 AWG) or coarser conductors.
- The SPD **shall** be UL 1449, 2nd Edition listed, and tested to clause 7.10. A test report from a Nationally Recognized Testing Laboratory (NRTL), NAVLAP or A2LA, or a Certified UL client testing data laboratory detailing the procedures used, and the results obtained **shall** be made available.

7.4.2.2 TYPE 2 PANEL TYPE SURGE PROTECTION DEVICE 120VAC SINGLE AND 3 PHASE SERVICES

Type 2 SPDs provide protection for the service entrance locations within the same equipment room. The requirements are as follows:

- The device **shall** consist of primary modules using MOV technology.
- The SPD **shall** be a permanently connected, one-port, or parallel configuration
- The suppression components **shall** be voltage limiting type. Voltage switching components **shall not** be utilized as a suppression element in the SPD.
- All suppression modules **shall** be installed from each phase conductor to the neutral conductor (L-N, Normal Mode).
- Suppression modules or devices of any type **shall not** be connected between any phase conductor and the equipment grounding conductor or ground (L-G, Common Mode Neutral to Ground).
- The primary module(s) **shall** consist of a Metal Oxide Varistor (MOV) module(s), with sufficient energy handling capability to meet the maximum discharge current requirement of 160kA per mode.
- The minimum pulse life or durability requirements and the voltage protection level **shall** be as specified in Table 7-4 for the respective Maximum Continuous Operating Voltage (MCOV) listed.
- SPD **shall** be properly selected based on the operating voltage and number of phases of the circuits to be protected.
- Each module or subassembly **shall** be modular in design to allow for easy field replacement.
- The SPD **shall** use integral over-current protective devices, and the SPD **shall** have a short circuit current rating of 25,000 amperes, as defined by UL 1449, second edition, Section 39.3.
- The SPD **shall** have a nominal discharge current of 10,000 amperes, as defined, and tested by IEEE C62.45.2-2002 waveform characteristics (Category C high 10 kA 6 kV minimum) SPD tested in accordance with IEEE C62.45-2002.
- The SPD **shall** have a voltage protection level (at the nominal discharge current of 10,000 amperes) of 800Vpk or less from each phase-to-neutral mode, when tested in accordance with IEEE C62.45-2002. Test points are measured using specified conductor size at a distance of 150 mm (6 in.) outside of the enclosure.
- The SPD **shall** have a Suppressed Voltage Rating (SVR) of 400 Vpk, as determined by testing in accordance with UL 1449, Second Edition, Section 34.

- The enclosure rating of the SPD **shall** be NEMA 4. The maximum dimensions of the enclosure **shall** be 406 mm × 406 mm × 228 mm (16 in. × 16 in. × 9 in.) for single-phase, 3W+G configurations, and 508 mm × 508 mm × 228 mm (20 in. × 20 in. × 9 in.) for three-phase wye, 4W+G configurations. The maximum weight of the SPD **shall** be 13.6 kg (30 lb), and 18 kg (40 lb) respectively.
- The environmental parameters of the SPD are as follows:
 - Operating temperature range: -40 °C to +65 °C
 - Storage temperature range: -40 °C to +65 °C
 - Operating humidity range: 0-95%, non-condensing
 - Altitude range: -152.4 m to 4572 m (-500 ft to +15,000 ft.)
- Connection to the SPD **shall** be conducted with a wire range of 16 mm² csa (#6 AWG) per NFPA 70-2005, Article 110 the conductor size must match the breaker size.
- Each SPD **shall** have indicator lamps on or visible from the front of the device showing that power is applied and that the protection integrity has not been compromised.
- The SPD **shall** include a set of form “C” dry contacts, rated at a minimum of 250 VAC, and a minimum of 2.0 amperes, with a power factor of 1.0, for remote alarm reporting capability. This set of contacts **shall** operate when there is an input power failure or the integrity of any module has been compromised. This contact set **shall** be isolated from the AC power circuitry to safeguard the alarm circuit or reporting device should a catastrophic event occur. Connection to the remote monitoring contacts of the SPD **shall** utilize 0.34 mm² (#22 AWG) or coarser conductors.
- The SPD **shall** be UL 1449, 2nd Edition listed, and tested to clause 7.10. A test report from a Nationally Recognized Testing Laboratory (NRTL), NAVLAP or A2LA, or a Certified UL client testing data laboratory detailing the procedures used, and the results obtained **shall** be made available to the Motorola National Site Design and Integration Process and Product Manager.

7.4.2.3 TYPE 3 INDIVIDUAL EQUIPMENT SPDs

Individual equipment SPDs are available in many varieties. These may be wire-in receptacle outlet replacement types, plug-in adapters, or receptacle outlet panels or strips. General requirements are as follows:

- All individual equipment devices **shall** provide Normal Mode (L-N) circuit protection.
- Common Mode (L-G) circuit protection **shall not** be permitted.
- Individual devices with the plug manufactured as a combined part of the device **shall** be designed to be plugged into a single simplex receptacle outlet and **shall** incorporate a single simplex receptacle outlet for the load connection. Individual plug-in units with a duplex receptacle outlet **shall not** be used.
- Multi-receptacle outlet strip devices may incorporate multiple receptacle outlets and may also incorporate telephone or data circuit secondary protection devices within the same housing.
- Multi-receptacle outlet strip devices **shall** incorporate an independent ground point on the exterior of the device. This attachment point or stud **shall** be suitable for attachment of a lug sized for a 16 mm² csa (#6 AWG) conductor.
- Multi-receptacle device housings **shall** be metallic and **shall** be provided with mounting ears, tabs or brackets. Devices may be suitable for standard EIA 483 mm (19 in.) rack mounting.

- Each device **shall** have an indicator lamp visible from the front of the device showing that the module has power applied and that the protection integrity has not been compromised. Alarm relay contacts to remotely report device failure may be offered but are not required.
- The minimum pulse life or durability requirements and the voltage protection level **shall** be as specified in Table 7-4 for the respective Maximum Continuous Operating Voltage (MCOV) listed.
- Installation of Type 3 SPDs on each critical load is recommended in locations highly vulnerable to transient surges or lightning activity when the critical load is located greater than 3 m (10 ft.) of conductor length from the Type 1 SPD. Where the load is located between 3 to 15.2 m (10 to 50 ft.) of conductor length from Type 1 devices a Type 3 device is optional. Where the load is located greater than 15.2 m (50 ft.) of conductor length (7.6 m (25 ft.) of circuit length) from the Type 1 device, a Type 3 device is highly recommended. (See Table 7-3.)

TABLE 7-3 SPD REQUIREMENTS BASED ON CONDUCTOR LENGTH

Conductor Length *		
0 - 3 m (0 - 10 ft.)	3 - 15.2 m (10 - 50 ft.)	> 15.2 m (>50 ft.)
Type 1 Required	Type 1 Required Type 3 Optional	Type 1 Required Type 3 Highly recommended**

* Lengths shown denote CONDUCTOR length. The CIRCUIT distance is ½ of conductor length shown.

In applications for standalone pole- or pad-mounted cabinets, where an SPD or a Type 2 SPD is not installed on the Utility Panelboard, Type 3 devices **shall be installed on all loads.

- The device **shall** be UL 1449, 2nd Edition listed. Devices may also conform to the international CE certification mark, and tested to clause 7.10. A test report from a Nationally Recognized Testing Laboratory (NRTL), NAVLAP or A2LA, or a Certified UL client testing data laboratory detailing the procedures used, and the results obtained **shall** be made available to the Motorola National Site Design and Integration Process and Product Manager.
- Each multiple receptacle outlet strip type device incorporating telephone or data circuit protection **shall** be UL 1449 and UL 497A listed or recognized. Devices may conform to the international CE certification mark.

TABLE 7-4 SPD SPECIFICATIONS

Type	Service Configuration	MCOV	Required Measured Testing				
			Safety	Performance			
			Surge Voltage Rating (SVR) UL 1449-2nd Edition	Duty Cycle Test, IEEE C62.41, 200A ringwave	Duty Cycle Test, IEEE C62.41	Nominal Discharge Current (I _n) ¹	Maximum Discharge Current (I _{max})
			6kV, 500A	6kV, 200A, 100 kHz	6kV, 3 kA	6kV, 10 kA	
Manual Section				7.10.3.3	7.10.3.4	7.10.3	7.10.4
Type 1							
High lightning exposure or main utility service on the load side of the disconnect	120/240 1φ	145	330	n/a	Required	VPL Recorded	Required
	120/208 3φ	145	330	n/a	Required	VPL Recorded	Required
	480/277 1φ	320	800	n/a	Required	VPL Recorded	Required
	230/380 3φ	280	n/a	n/a	Required	VPL Recorded	Required
Type 2							
High lightning exposure Service entrance Suitable for branch service applications on load side of utility disconnect	120/240 1φ	145	400	n/a	Required	VPL Recorded	Required
	120/208 3φ	145	400	n/a	Required	VPL Recorded	Required
	480/277 1φ	320	800	n/a	Required	VPL Recorded	Required
	230/380 3φ	280	n/a	n/a	Required	VPL Recorded	Required
Type 3							
Branch circuit protection device	120 V	145	330	Required	n/a	n/a	n/a
	230-240V	280	570	Required	n/a	n/a	n/a

1. Nominal Surge Current Value (I_n) is a single 10 kA impulse. This single impulse **shall** be applied at the SPDs and the Voltage Protection Level (VPL) measured and recorded.

7.4.3 INSTALLATION REQUIREMENTS

All SPDs **shall** be installed per the manufacturer's installation instructions and in accordance with all applicable codes. Type 1 and Type 2 devices **shall** be securely attached to the mounting surface and **shall not** depend on the interconnecting raceway for support.

7.4.3.1 LOCATION

When selecting the location, consideration must be given to conductor routing, length and required number of bends in each conductor. The SPD **shall** be installed as close as possible to the associated main disconnect or panelboard, and in a location that permits the shortest and most direct electrical connection. The most suitable location is immediately adjacent to the associated panelboard keeping the conductor length as short as possible. To accommodate this specification some manufacturers have developed specific models for installation directly above, below, or to the right or left of the associated panelboard.

7.4.3.2 INTERCONNECTING RACEWAY OR CONDUIT

The raceway or conduit between the panelboard (or disconnecting means) and the SPD **shall** be sized for the size and number of conductors to be routed through it. A non metallic conduit (such as PVC) or raceway is recommended. The length **shall** be as short as possible. This raceway **shall** be routed as direct as possible between the SPD, the disconnecting means (if a separate enclosure is used), and the associated panelboard. The raceway or conduit **shall not** be used as a support for the device.

7.4.3.3 CIRCUIT BREAKER OR DISCONNECTING MEANS

The SPD **shall** be wired through a 60-Ampere (or larger) circuit breaker, NFPA 70-2005, Article 110.9, or in accordance with local jurisdictional codes.

7.4.3.4 CONDUCTOR SIZE, LENGTH AND ROUTING

Conductor size, total circuit length, and routing are critical to proper SPD performance. The conductor **shall** be of the minimum size recommended by the manufacturer, however, **shall not** be smaller than 16 mm² csa (#6 AWG). Larger conductor sizes are most desirable. A maximum conductor length of 610 mm (2 ft.) is most desirable. The conductors **shall** be routed together and **shall** be free of sharp bends or angles of less than 90 degrees.

7.4.3.5 PERFORMANCE EVALUATION

SPDs **shall** be evaluated using the specific criteria outlined in "AC Power Line SPD Test Certification Requirements" on page 7-47, and **shall** meet the requirements established in this section and Table 7-4 on page 7-32. Devices that do not meet this minimum criteria **shall not** be furnished, installed, or recommended for installation.

7.5 TELEPHONE/CONTROL/DATA NETWORK CIRCUIT SPDs

All copper circuit conductors entering any communications site, shelter, room equipment area or pole/pad mounted cabinet **shall** be protected with suitable SPDs. NFPA 70 requires that telephone, communications or data type circuit conductors be properly surge protected with a primary SPD as close as practicable to the point of entry into the structure or building (NFPA 70-2005, Article 800.90). Some applications may require fused or resettable fuse type primary protection devices. SPDs equipped with jacks or cords and plugs **shall** have all through conductors protected. Conductors that are not extended through the device **shall** be bonded to the ground (earth) connection point. The protected (equipment) and unprotected (line or CO) terminations **shall** be clearly marked. A grounding conductor or a ground connection post or terminal **shall** be provided. Devices that have the grounding conductor incorporated by the manufacturer as an integral part of the device **shall** utilize an 4 mm² csa (#12 AWG), green jacketed, stranded copper conductor for a single line (2 pr, 4 conductor) device or a 16 mm² csa (#6 AWG), green jacketed, stranded copper conductor for a multi-line device. The conductor provided as an integral part of the device by the manufacturer **shall** be a minimum of 1.2 m (4 ft.) in length to accommodate various installation requirements. When installed, this conductor **shall** be cut to the length required to permit attachment to the ground bus or equipment grounding conductor and **shall** be as short as possible to help ensure maximum protection. The ground connection post or terminal **shall** be suitable for connection of an 4 mm² csa (#12 AWG) conductor for a single line device or a 16 mm² csa (#6 AWG) conductor for a multi-line device. All ground conductors **shall** be mechanically attached to the device circuit board and **shall not** be dependent on solder for connection integrity. The voltage limiting devices **shall** be connected between the line conductors and ground.

Primary and secondary SPD operating voltages are application dependent and **shall** be properly chosen. Coordination between the Primary and Secondary devices **shall** be considered to ensure the most effective level of surge protection. High speed data circuits require SPDs designed for these applications.



WARNING

See Chapter 5 for the proper grounding of the metallic sheathing of communications cables.

7.5.1 PRIMARY PROTECTION

The primary SPD installation **shall** comply with all applicable codes. The devices **shall** be UL 497 listed or conform to the international CE certification mark (NFPA 70, Article 800.90(A) and Article 800.170(A)). The SPD **shall** be installed at the entrance point into any building and within close proximity to the electrical service entrance and the master ground bus bar. In lightning prone areas, a primary SPD **shall** also be installed on each end of an inter-building cable run to help ensure that high energy is not allowed to penetrate the building interior (NFPA 70-2005, Article 800.90(A)). In some applications a fused type primary SPD may be required. (See NFPA 70-2005, Article 800.90(A)(2) for additional information.) To reduce the need for fuse replacement, devices that incorporate resettable fuse technology are recommended. Primary SPDs are available from most telephone product distributors and are typically supplied during installation by the telephone circuit supplier. The purpose of primary protection is to help ensure personnel safety and help protect internal cables from extremely high voltage. The primary SPD **shall** be grounded (earthed) in accordance with NFPA 70-2005 Article 800.100 or other applicable codes, industry standards, and as outlined in Chapter 5, "Internal Grounding (Earthing)." The ground conductor **shall** be as short as possible, **shall** be routed as directly as possible to the ground bus or MGB, and **shall** be as free of bends as is possible.

NOTE: Contractors engaged by Motorola to install or move communications cable runs between buildings **shall** abide by local codes and standards governing the installation of communication cable runs.

7.5.2 SECONDARY PROTECTION

Secondary SPDs (silicon avalanche diode technology preferred) **shall** be installed. The SPDs **shall** be installed as close to the equipment being protected as possible. This includes (but is not limited to) the circuits associated with the base stations, repeaters, remotes, modems, consoles, Network Interface Units (NIUs) and channel banks that extend from the shelter, room or equipment area. This also includes any circuit located within one building, but extending outside the immediate equipment room or area. Secondary SPDs **shall** comply with safety and performance standards for their designated use per Table 7-2 on page 7-10, and be UL 497A listed for the purpose (NFPA 70, Article 800.90(D) and Article 800.170(B)). The device may also conform to the international CE certification mark. Secondary protection may be included as an integral part of a Type 3 multiple receptacle outlet strip.

NOTE: The installation of a secondary SPD does not negate the need for a primary device where copper circuit conductors enter the building, shelter or equipment area.

The purpose of secondary SPDs is to limit transient over voltages to as close to the prescribed operating level of the protected equipment as is possible. The SPD also serves as a barrier against transient anomalies that may be induced between the cable entrance point and the equipment, and in cable runs within the building or shelter interior. The secondary SPD ground conductor **shall** be bonded to the equipment grounding (earthing) conductor or ground bus conductor as outlined in Chapter 5, "Internal Grounding (Earthing)." This conductor **shall** be as short as possible, free of sharp bends, and **shall** be routed as directly to the equipment grounding conductor or ground bus as is possible.

The operating voltage and SPD configuration is application dependent. The lowest suitable voltage should be chosen to ensure the most effective level of surge suppression.

**CAUTION**

The manufacturer must verify that the SPD is suitable for use on high bandwidth data circuits in excess of 1.54 Mbs.

**CAUTION**

SPDs using SAD technology may develop an artificial diode bias when subjected to strong RF fields that may be experienced at AM, FM or TV broadcast sites. This bias may cause data circuit errors.

7.5.3 FIBER OPTIC CABLES

An intrinsic benefit of fiberglass (fiber optic) telephone lines is that they offer excellent isolation from lightning induced ground potential rise, line-induced lightning strikes, RF, and electrical noise coupling. The “fiber” telephone/data line is far from perfect as it can melt when subjected to high energy strikes or fire. No primary SPD is required for fiber circuits entering a building, shelter or equipment area; however, any metallic shield, jacket or drain conductor **shall** be bonded to the MGB. A secondary SPD may be installed on the equipment end of copper circuit conductors originating at a fiber optic network interface unit (NIU) in areas where the level of lightning exposure is high.

Suitable surge suppression devices offering primary and secondary protection are available from several surge suppression device manufacturers. Devices **shall** be selected based on the specific application and requirements specified above.

7.6 RF COMPONENTS PROTECTION

RF transmission lines from the antenna structure to the shelter or building **shall** be grounded (earthed) as described in Chapter 4, “External Grounding (Earthing).” Upon entering the shelter or building, all RF transmission lines (including sample port (test) and unused spares) **shall** route through coaxial RF-type SPDs. The coaxial RF devices **shall** be bonded to the single point ground window as described in Chapter 5, “Internal Grounding (Earthing).” The SPD **shall** be located within the shelter, room or equipment area and **shall** be a maximum distance of 610 mm (2 ft.) from the transmission line entrance point into the shelter, room or equipment area as shown in Figure 7-22 on page 7-42. Some RF surge protection products can be installed at or within the entry port; this is the most desirable location to install coaxial cable SPDs if the entry port is located in the wall of the shelter, equipment room or area. If the equipment room or area is located within a larger building (such as a high rise structure), it is desired that the SPDs are installed and grounded at the coaxial entry point into the structure. In this application, the transmission lines **shall** also have SPD installed and **shall** be grounded at the point where they enter the equipment room(s) or area(s).

NOTE: SPDs are required to be installed at the building entry point to reduce the radiated RF energy generated by a lightning strike.

NOTE: Unused coaxial cables connected to the outside **shall** be properly terminated by grounding the shield to the ground entry port and installing a SPD with a shorting stub or 50 ohm load. Excess cable **shall** be stored so as not to come in contact with equipment or personnel.

7.6.1 RF SURGE SUPPRESSION TECHNOLOGY OVERVIEW

There are three basic technologies used in the design of RF surge protection devices:

- RGT (Replaceable Gas Tube), DC open
- Quarter Wave Stub, DC short
- Broadband High Band Pass Filter, DC blocked

When selecting the proper RF suppression technology for a given application, attention should be paid to the operating characteristics inherent to each type of device, as well as system compatibility and surge suppression performance. Examples of surge performance characteristics for the three basic RF suppression technologies are provided below.

7.6.1.1 REPLACEABLE GAS TUBE

A straight Gas Tube-based coaxial protector without DC blocking has DC continuity from the surge-side connector center pin to the equipment-side connector center pin. The fast rise-time lightning pulse can produce a high magnitude voltage across the Gas Tube before the gas can ionize and begin to conduct. Because there is no DC blocking mechanism, this high voltage impulse is applied directly to the equipment input before the gas tube “turns on.” If the protected equipment input routes through a ferrite circulator/isolator, the incoming pulse is converted to current in the ferrite’s resistive load. This creates a magnetic field that can realign the critically adjusted field in the circulator, thereby changing the magnet’s flux density. This can damage or destroy the resistive load. If the incoming voltage pulse appears across a coupling loop (as in most filters and combiners), it sees a low resistance short and is almost entirely converted to current. A DC-shortened equipment input loop, which is quite common, directly shorts the Gas Tube. The Gas Tube may never see enough voltage to “turn-on” because current flow must go through the coaxial cable jumper and equipment input before an inductive voltage drop across the Gas Tube can reach a potential high enough to ionize the gas. Do not assume that a 90V gas tube will provide a 90V protection level for the equipment, because the voltage rating is based on a static DC voltage measurement. The Gas Tube is essentially a voltage dependent switch that reacts to the dv/dt of a lightning impulse. The typical voltage breakdown level for a 5kV/ μ s impulse is approximately 700 Vpk.

Straight Gas Tube protection devices allow DC current and voltage to be supplied to the tower top electronics. It is important to understand the operating characteristics of this protection technology. Tower top electronics consists of semiconductor-based preamps, power supplies, diplexers, telemetry, etc. Coordination of protection levels of the Gas Tube-based devices and the susceptibility of the protected electronics must be taken into account.

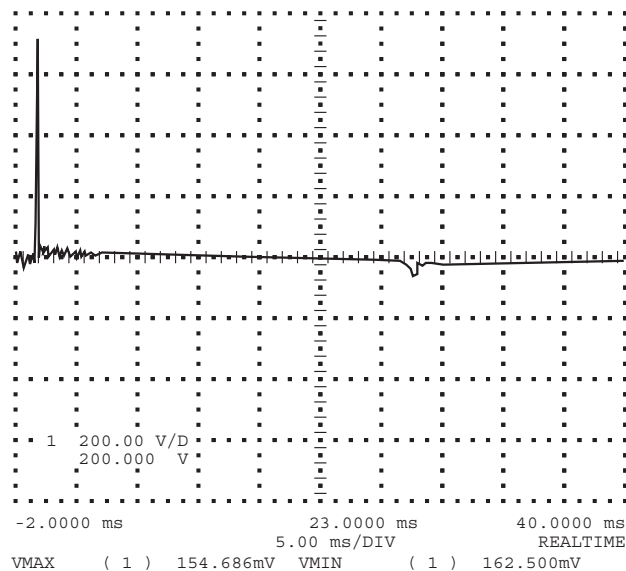

FIGURE 7-19 GAS TUBE AT 200V/DIV V AND 5 μ S/DIV H, 8x20 μ S/3kA

7.6.1.2 QUARTER WAVE STUB

The “Quarter Wave Stub” coaxial protector is based on the well-known bandpass/band-reject principle. Using a coaxial **T** fitting and calculating the length of a quarter-wave coaxial section from the horizontal center conductor to the grounded (earthed) base of the **T** can form a bandpass filter at a given frequency. Because most of the energy in a lightning strike is from DC to 1 MHz, it falls on the lower frequency reject side of the bandpass filter and is conducted to ground. However, because the equipment input is usually DC-short to chassis or earth, and because the quarter-wave stub is connected to earth with an inductive copper conductor, there will be divided DC and low-frequency energy flowing into the equipment input.

Quarter-wave devices cannot be used where DC currents and voltages are required to power RF electronics. By their nature, they are tuned devices, and therefore have relatively narrow operating bandwidths (approximately +/-10% of the operating frequency).

Shorted inductor (or shorted stub) lightning surge protection devices can appear electrically as an open circuit or a short circuit, depending on the applied radio frequency and physical dimensions of the transmission line inductor or stub. Within the designed frequency band, the shorted inductor or stub appears as an infinite impedance, producing very little passive insertion loss. Shorted inductors are indeed “shorted” at DC and frequencies outside the designed passband.

Shortcomings of the shorted inductor lightning protector which must be considered are that it will pass on-frequency lightning energy and that it must be made of compatible, non-ferrous materials or it also generates intermodulation. The shorted inductor will not allow DC to pass; therefore it is not suited in CCTV, tower top amplifier, and GPS receiver applications where DC bias is multiplexed on the RF transmission line. There are shorted stub inductor lightning protectors available that place a neon tube device in series with the tuned circuit to provide DC isolation.

While this solves the DC voltage problem for tower top amplifier and GPS applications, it significantly limits current-handling capacity of the protection device and does not reduce the let through voltage to the level required for equipment survivability; such devices **shall not** be used.

The shorted stub inductor device is frequency-sensitive, therefore it must be selected for the specific frequency band in use. Different bands multiplexed on the same transmission line will not work with band-limiting devices such as the shorted stub inductor. The shorted stub inductor device is mechanically large compared to other gas protector/reactive filter lightning surge protector devices in common use. There could quickly develop an installation space problem if a number of transmission lines are protected by individual shorted stub inductor devices at the common facility cable entrance port. The shorted inductor type device differs somewhat from the shorted stub inductor type device in that the shorted inductor type device incorporates a helical wound shorted inductor. These devices typically exhibit an open DC circuit through the device and have a much larger bandpass than a shorted stub inductor device.

All coaxial RF surge suppression devices **shall** exhibit an open DC circuit through the device (unprotected port center pin to protected port center pin), except those specifically designed to pass DC for CCTV, tower top amplifiers and GPS installations as described in this chapter and “GPS Receiver Protection” on page 7-44. The input and output ports **shall not** be directly connected and may have a capacitive or reactive network installed within the device to permit the RF energy to pass. The unprotected port and the protected port **shall** be clearly marked on the device.

Typical RF characteristics for RF SPD are voltage standing wave ratio (VSWR) of less than or equal to 1.1:1 (return loss of -26.4dB) and an insertion loss of less than or equal to 0.1 dB over the network operating frequency range. These devices are also specified to handle surge currents from 10-20kA 8/20 μ s waveform. Selection of the proper SPD for RF transmission lines depends on the specific application.

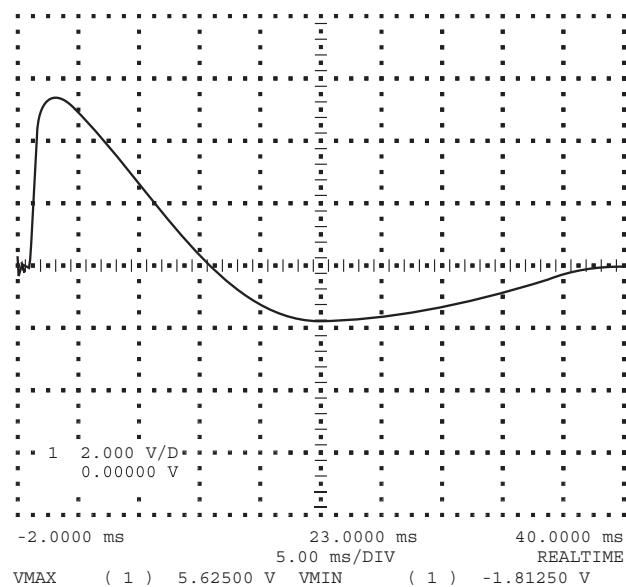

FIGURE 7-20 QUARTER-WAVE STUB, OSCILLOSCOPE SET AT 2V/DIV V AND 5 μ S/DIV H, 8x20 μ S/3KA

7.6.1.3 FILTER-BASED COAXIAL PROTECTORS

Filter-based lightning protection devices are characterized by their broadband performance characteristics and can cover multiple transmit/receive frequency bands. These cavity-based designs can be characterized as bandpass filters. They consist of tuned inductive capacitance (LC) networks operating on a bandpass/band-reject principle, with an operating band as broad as 2 GHz. Utilizing the inductive current discharge circuit to shield/ground, followed by a DC blocking capacitive component on the center pin, ensures not only broadband RF performance, but also the desired surge suppression characteristics. Designs based on this principle allow a closer match to 50 ohms over a broader range than the quarter-wave technique. These devices cannot be utilized in applications where DC currents and voltages are supplied to the RF electronics via the coaxial cable's center conductor.

Note that a modified form of this filter-based technology can be deployed in applications requiring DC power for the tower top electronics. There are designs combining DC blocking for the RF while passing DC power for the tower top electronics. The design is similar to the Bias-T concept. While the RF surge performance relies on the filter concept, the DC path is isolated from the RF path, conditioned, and re-injected at the appropriate port. While selecting this type surge protector, attention should be paid to the resistance of the DC protection circuit. The typical DC resistance range could be from a few milliohms to a few ohms.

Some tower top amplifier configurations incorporate a control and alarm cable in addition to the RF transmission line and sample port (test) cable. This control and alarm cable is typically a multi-conductor cable connecting the tower top amplifier unit collocated with the receive antenna to the control chassis collocated with the receiver multicoupler. This cable is typically installed and routed with the receive antenna transmission line. Any shield within this cable **shall** be bonded to the MGB.

All conductors of this cable **shall** be protected by installation of a suitable SPD within a maximum of 610 mm (2 ft.) of the point of entry into the shelter, room or equipment area. The ground (earth) terminal of the SPD **shall** be bonded to the MGB with a 16 mm² csa (#6 AWG) or coarser, green jacketed, stranded copper conductor.

The specifications for this SPD will be dependent on the design parameters of the tower top amplifier system, including the operating voltage and number of conductors within the control or alarm cable. The proper SPD **shall** be selected for the specific application. The device selected should have a turn-on voltage that is nominally 20% higher than the maximum DC operating voltage; however, the turn-on voltage **shall** be low enough to provide suitable protection. The tower top amplifier system and SPD manufacturer should be consulted for guidance in selecting the proper SPD.

CCTV and Cable TV system cables entering a communications facility **shall** have SPDs installed. These cables, like RF transmission lines, should by design enter the shelter, room or equipment area at the same location as the RF transmission lines. When there are no RF transmission lines at the facility where these systems are installed (dispatch and command centers) the cables should enter as close as is practicable to the point where the power and telephone conductors enter the facility. The shield of these cables **shall** be bonded to the MGB. The SPD **shall** be installed within 610 mm (2 ft.) of the point of entry of the cable(s) into the shelter, room or equipment area. The ground terminal of the SPD **shall** be bonded to the MGB with a 16 mm² csa (#6 AWG) or coarser, green jacketed, stranded copper conductor as described in Chapter 5.

The proper SPD **shall** be selected based on the application. Some CCTV systems will provide DC power to the remote camera via the coaxial cable. The cable TV service provider or the CCTV manufacturer, as well as the SPD manufacturer, should be consulted for guidance in selecting the proper SPD for the specific application.

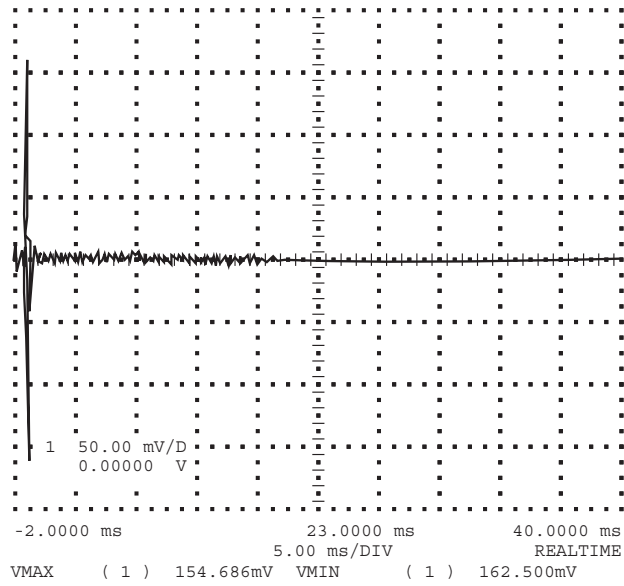
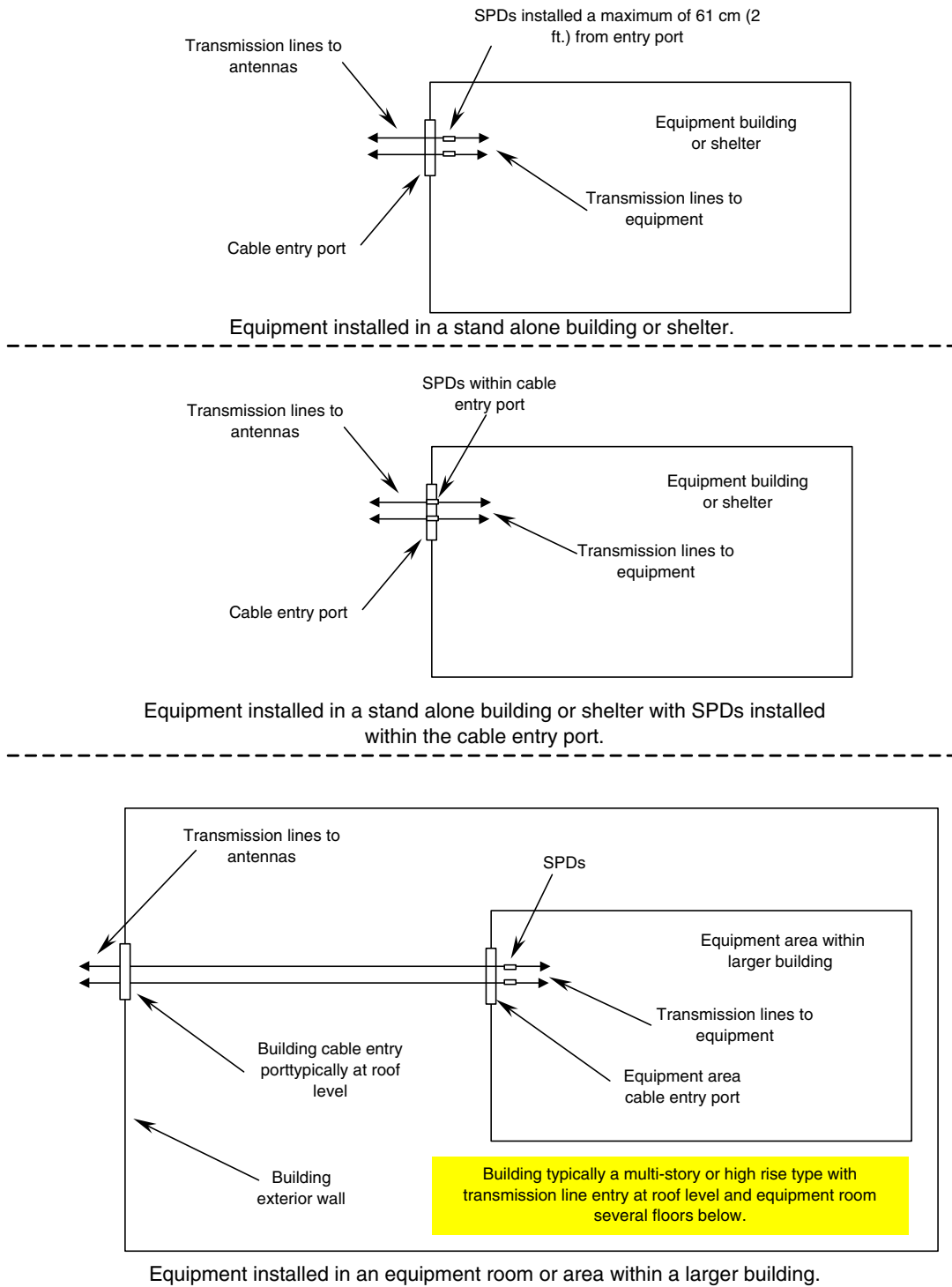

FIGURE 7-21 FILTER-BASED RF PROTECTION DEVICE, OSCILLOSCOPE SET AT 0.05V/DIV V AND 5 μ s/DIV H, 8x20 μ s/3kA



NOTE: Grounding and electrical details not shown.

FIGURE 7-22 TRANSMISSION LINE SPD INSTALLATION LOCATIONS

7.6.2 SURGE PROTECTION CONSIDERATIONS FOR DISPATCH CENTERS AND OPERATOR POSITIONS

Dispatch centers co-located with communications towers require special protection considerations due to the critical nature of their operation and due to the inherent risk to personnel from lightning. For optimum dispatch center protection, the following **shall** be considered:

- Site design recommendations given in “Design Considerations to Help Reduce Effects of Lightning” on page 2-19.
- Internal grounding and bonding as defined in “Grounding (Earthing) for Dispatch Centers and Network Operator Positions” on page 5-62.
- Electrostatic discharge (ESD) precautions as defined in Appendix B.
- External grounding as defined in “External Grounding (Earthing) For Dispatch Centers Co-located With Communications Towers” on page 4-81.
- Transient Voltage Surge Suppression as follows:

7.6.2.1 MINIMUM SPD REQUIREMENTS

- Type-2 (min) service panel SPDs **shall** be required for AC electrical panels servicing the dispatch operations center and **shall** be located so as to provide the most effective surge protection (see “Installation Requirements” on page 7-33).
- Type-1 (min) SPDs are required for UPS panelboards located within the dispatch operations center when the UPS system is located more than 15.2 m (50 ft.) from the center.
- Type-3 SPDs are required for each dispatch operator position. Type-3 SPDs used **shall** be qualified Motorola compliant devices and must incorporate an external ground (earth) stud or connection point and **shall** be grounded to the operator position ground bus bar in accordance with ANSI T1.321-R2000.
- Telephone and network interface cables **shall** be surge protected and grounded as described under “Telephone/Control/Data Network Circuit SPDs” on page 7-34. Additional surge protection for headset jack interface points is recommended to reduce the possibility of shock or discomfort caused by lightning and electrostatic discharge (ESD). Headset protection units **shall** be grounded to the operator position ground bus bar.

NOTE: ESD is generally the cause for many complaints generated by dispatch personnel. Measures to control ESD **shall** be taken when designing for this environment. Most ESD problems are mitigated through proper bonding and grounding techniques, relative humidity control (between 40% and 55% relative humidity is ideal) and attention to the resistivity of flooring and furniture. Video Display Terminals (VDT), keyboards and the mouse are additional areas where energy can build up between the equipment and personnel. Proper static resistive mats and pads can reduce discomfort and injury caused by ESD. Cathode tubes used in some VDTs generate powerful electrical fields, and while there are screens and mats to help to minimize the effects of electrostatic discharge between equipment and personnel, it does not negate the need for training personnel on the proper skills to avoid coming in contact with ESD.

7.6.3 CABLE TELEVISION AND SECURITY SYSTEMS

Closed circuit television (CCTV), cable television, and security system cables entering a communications facility **shall** have SPDs installed. Cable television and CCTV cables, like RF transmission lines, should by design enter the shelter, room or equipment area at the same location as the RF transmission lines. When there are no RF transmission lines at the facility where these systems are installed (dispatch and command centers), the cables should enter as close as is practicable to the point where the power and telephone conductors enter the facility. The shield of these cables **shall** be bonded to the MGB. The SPD **shall** be installed within 610 mm (2 ft.) of the point of entry of the cable(s) into the shelter, room or equipment area. The ground (earth) terminal of the SPD **shall** be bonded to the MGB with a 16 mm² csa (#6 AWG) or coarser, green jacketed, stranded copper conductor as described in Chapter 5, “Internal Grounding (Earthing).”

The proper SPD **shall** be selected based on the application. Fixed camera systems can be AC or DC powered; Pan Tilt Zoom (PTZ) cameras are typically 24 or 110 volt AC powered. Consult with the security provider or the manufacturer before selecting the SPD for this application. It is highly recommended to protect PTZ cameras at both ends of the cable run.

SPDs **shall** be installed on alarm circuits entering the communications site and installed within 610 mm (2 ft.) of the cable entry port and with the shields bonded to the MGB (NFPA 70-2005 Article 800.100(B)). Primary SPDs, within 610 mm (2 ft.) of where the cable enters the building, **shall** be installed in accordance with NFPA 70-2005 Article 800.90, and secondary SPDs, NFPA 70-2005 Article 800.90(D), are highly recommended at the security systems head-in.

7.6.4 BROADBAND - WIRELESS ACCESS POINT NETWORKS

SPD considerations for broadband **shall** include the use of SPDs to protect pole-mounted access points and ground-based cabinet architecture. It is important to install proper SPD applications on both ends of Ethernet, Power-Over Ethernet (POE), Giga-Ethernet (GigE) and AC cable runs. SPDs **shall** be located within the node or cabinet, or as close to the entrance as possible, and properly installed into load centers, control panels and utility power cabinets. While RF protection is a consideration, it **shall** only be required when antennas are connected to the node with coaxial cables greater than 610 mm (2 ft.) in length.

7.7 GPS RECEIVER PROTECTION

Global Positioning System (GPS) receivers are often a part of a modern communications system. GPS receivers are used for site timing and synchronization. Failure of a GPS receiver will usually render the radio system unusable. GPS receiver systems on telecommunications sites typically include a GPS receiver which is built-into the basic radio equipment, an amplified GPS antenna unit, and low-loss transmission line. The GPS antenna includes a GaAsFET device wideband RF amplifier. The RF amplifier is fed with low-voltage DC (around 15 VDC) through a multiplex arrangement using a single coaxial transmission line which also serves to couple the incoming GPS signal from the antenna to the receiver. A fused power supply within the radio equipment provides the RF amplifier operating voltage.

Damage to the GPS receiver can be induced directly from an antenna head strike, or through induced coupling from other transmission lines on the same antenna structure. There is little that can be done to effectively protect the GPS antenna unit itself from direct lightning strikes, other than to assure that it is **never** mounted at the highest point on the tower. The GPS system coaxial transmission line **shall** be installed and grounded (earthed) in accordance with the practices described in Chapter 4, “External Grounding (Earthing).” A special GPS coaxial RF SPD **shall** be installed within 610 mm (2 ft.) of the cable entry port and bonded to the MGB as described in Chapter 5, “Internal Grounding (Earthing).” Also see “RF Components Protection” on page 7-36 and Figure 7-22 on page 7-42.

The GPS compatible RF coaxial lightning protector is different from normal coaxial protectors in that it is designed to pass the DC bias through the coaxial line which is required to power the antenna-mounted amplifier. Before selecting a coaxial SPD, it should be verified that the GPS receiver can operate with an SPD in the coaxial line. In most installations the GPS receiver will require optimization to compensate for the delay caused by the SPD and the variations in the length of the transmission line (which is site specific). The GPS antenna transmission line **shall** be cut to the proper length as excess transmission line **shall not** be coiled either inside or outside the shelter, room or equipment area.

All coaxial RF surge suppression devices **shall** exhibit an open DC circuit through the device except those specifically designed to pass DC for CCTV, tower top amplifiers and GPS active antenna installations. These devices **shall** incorporate a circuit to pass the DC power while providing suitable surge protection for the DC circuit path. The input and output ports **shall not** be directly connected and may have a capacitive or reactive network installed within the device to permit the RF and DC energy to pass.

A DC injector/DC path coaxial hybrid RF SPD will typically have a turn-on voltage nominally 20% above the maximum DC operating voltage, with a turn-on time of 4 nsec for 2 kV/nsec. This protector will also offer a VSWR of less than or equal to 1.2:1 (return loss of -20.8dB) over the frequency range, and an insertion loss of less than or equal to 0.3 dB, handling a 20 kA, ANSI C62.1 8/20 waveform of 200 Minimum (+ and -) Alternating at 200 A per 62.41-2002.

The proper surge suppression device **shall** be selected for the specific application. Different active GPS receiver antennas will have different DC power supply voltages on the transmission line. The device selected should have a turn-on voltage that is nominally 20% higher than the maximum DC operating voltage; however, the turn-on voltage **shall** be low enough to provide suitable protection.

7.8 TOWER LIGHTING PROTECTION

All tower lighting system power, control and alarm conductors **shall** have SPDs installed at the point of entry into the building, shelter, room or equipment area. If the equipment room or area is located within a larger building and several ft away from the point where the conductors enter the building, the SPDs **shall** be installed within 610 mm (2 ft.) of the equipment room or area entry point or wall penetration.

AC power conductors **shall** have normal mode (L-N or L-L) surge suppression devices installed. Common mode (L-G) devices **shall not** be used on AC power circuits, although common mode devices will provide the most effective suppression on alarm and modem circuits and may be used on these circuits.

Tower lighting protection is typically overlooked in communications facility design. Tower lighting systems typically use either incandescent lamps, strobe lighting or both. These systems are typically powered from an AC circuit originating from the utility panelboard. Conductors connecting the lamps or lighting heads to a control unit at the tower base may be installed within conduit or be attached directly to the tower structure. Routing of flexible lighting power and controller cables is critically important.

**CAUTION**

Tower lighting cables shall not be bundled along with transmission lines or other conductors anywhere within cable ladders, or the building interior.

Tower lights or beacon power and control conductors can provide a path for conducting lightning energy into the shelter, building or equipment area. These conductors should be installed such that lightning energy **shall not** be routed through the building, shelter, room or equipment area where this energy may be inductively coupled into critical equipment interconnecting cables. For this reason an exterior location is preferable and highly recommended for the light controller panel. Many manufacturers provide a weatherproof enclosure suitable for outdoor installation as a standard product. Others offer the weatherproof enclosure as an option, which can be easily ordered. The weatherproof tower light controller housing may be mounted to a tower leg, a pedestal alongside of the antenna structure or to the exterior surface of the shelter or building.

If the tower lighting controller is installed within the building, shelter, room or equipment area, it **shall** be located as close to the cable entrance port as practicable. All control unit metallic housings **shall** be bonded to the exterior ground (earth) system or the interior perimeter ground bus or MGB based on their location.

Strobe lighting systems may use voltages in excess of 600 VDC; therefore, installation of a surge suppressor on these power conductors to the strobe light heads is not reasonable and will not adequately reduce surge voltages that may enter the shelter. For this reason it is recommended that tower lighting controllers be located outside the shelter. Suppressing voltage transients on the AC power, alarm and modem conductors of control units located outside the shelter, building or equipment area can be effectively done by installation of a suitable SPD at the point of entry of the conductors into the shelter, building or equipment area. Tower light AC power, alarm and modem cables **shall** enter the shelter, building or equipment area within or adjacent to the antenna transmission line entry port location. The ground conductors of the SPDs **shall** be bonded to the MGB at this point.

Some tower lighting manufacturers offer an optional surge suppression device that may be installed within the tower lighting control unit. Although this device may be suitable for protecting the control unit circuitry, it does not provide adequate protection to inductively coupled energy that may enter the shelter, building or equipment area through the tower light power or control conductors.

Suitable surge suppression devices offering protection for AC power, control and modem circuits are available from several surge suppression device manufacturers. Devices **shall** be selected based on the specific application and requirements specified above.

7.9 BATTERY POWERED PROTECTION

As telecommunications systems and sites have changed, so have power requirements. Cellular, PCS, and iDEN systems typically operate from a battery plant. Motorola Communications Enterprise equipment is also available with a DC power capability. The battery plants are usually powered by AC battery charging systems. Cellular, PCS and iDEN Mobile Switching Offices (MSO) or Central Offices also operate from a large battery system. Most of these sites adopt the telephone/microwave systems convention of -48 VDC, but some applications can use ± 24 VDC as well as 12 VDC.

A battery powered site offers a level of isolation from the AC power system affording some surge protection, voltage regulation, and electrical feed noise suppression to the equipment load. A battery system will attempt to maintain a normalized voltage, absorbing variations in voltage. This can be an effective method of surge suppression when the equipment is located within a conductor length of 6.1 m (20 ft.) from the battery plant; or a circuit length of 3 m (10 ft.) from the battery plant.

A DC SPD in the form of a SAD and MOV matrix device is recommended for installations where the equipment is separated from the battery plant by a conductor length exceeding 6.1 m (20 ft.); or a circuit length exceeding 3 m (10 ft.) from the battery plant. This protection is also recommended for installations in an area where the level of lightning exposure is high. The SPD voltage rating and polarity **shall** be coordinated with the circuit voltage and polarity of the battery plant. To maximize the effectiveness, the SPD should be installed at the equipment to be protected. Additional devices are recommended for each DC equipment load at the site.

Suitable surge suppression devices are available from several surge suppression device manufacturers. Devices **shall** be selected based on the specific application and requirements specified above.

7.10 AC POWER LINE SPD TEST CERTIFICATION REQUIREMENTS

AC power line SPDs which are recommended, distributed or installed by Motorola **shall** meet the specifications requirements cited in “AC Power SPD Requirements” on page 7-5, and those specified in Table 7-4 on page 7-32. Additionally, these devices **shall** have been certified as meeting the criteria cited in “Impulse Surge Durability Test Requirements” on page 7-49 below.

Manufacturers of AC power line surge suppression devices have an independent Nationally Recognized Testing Laboratory (NRTL), NAVLAP or A2LA, or a Certified UL client testing data laboratory detailing the procedures used, and the results obtained **shall** be made available.

Each manufacturer will submit and test their products for compliance with the specifications cited in “AC Power SPD Requirements” on page 7-5, and Table 7-4 on page 7-32. These tests **shall** follow the procedure outlined in the “Impulse Surge Durability Test Requirements” below and **shall** be done at no cost to Motorola. The results of these tests **shall** be certified by the independent laboratory and **shall** be submitted to representatives of Motorola for review. Devices that have been tested following the procedure established below and found to be compliant with the specifications cited in “AC Power SPD Requirements” on page 7-5, and those specified in Table 7-4 on page 7-32 **shall** be considered to have met the device requirements established by Motorola.

Motorola **shall** be afforded the opportunity to have their representative or representatives present at the time of the testing to witness and verify the test data compiled by the independent laboratory. The manufacturer may request that the test results be considered proprietary and may request that the information not be disclosed by representatives of the independent laboratory or Motorola. Motorola will be notified 30 days prior to the test in order to facilitate scheduling to witness the testing. After completion of the testing, manufacturers will have 30 days to compile the testing data and submit to Motorola for review. Motorola will have 30 days to advise the manufacture as their acceptance, or refusal of the results of the test data.

Motorola, at their option and expense, may purchase additional units from the manufacturer's normal production and have these devices tested by an independent laboratory of their choice following the same test criteria. Should it be found that the units purchased fail to meet the requirements as defined in "AC Power SPD Requirements" on page 7-5, and Table 7-4 on page 7-32, the manufacturer **shall** be notified. Motorola may, at their option, discontinue recommending, distributing or installing the product at any time.

7.10.1 TEST METHODS

This section describes the required tests for motorola certification. These tests are designed to stress the SPD to meet the requirements in this document. These are performance tests that exceed the UL 1449 2nd edition safety test. In addition to these required tests, UL 1449 2nd edition listing is required.

All tests for Type 1 and 2 SPDs will require a pre-test of 6 kV (minimum), 10 kA 8x20 usec Impulse as described in IEC 61643-1. The Voltage protection Level (VPL) is then recorded. After the required tests are performed a Post-Test of 6kV (minimum), 10kA 8x20usec Impulse as described in IEC 61643-1 will be performed and the result from the Post-Test must be within 10% of the Pre-Test VPL.

Each Test will require one test sample

7.10.2 COMPONENT LEVEL SURGE TEST

7.10.2.1 GENERAL

This test will test the individual surge module/s of Type 1 and 2 SPD's to show that they meet the requirements in this document. The SAD module/s are required to meet 20 kA single impulse with the VPL not deviating more then 10% in pre and post I_n (Nominal) testing. The MOV module/s are required to meet 160 kA single Impulse with the VPL not deviating more then 10% in Pre and Post I_n (Nominal) testing. All referenced surge currents are based on 8X20 uSec waveforms.

7.10.2.2 I_n (NOMINAL CURRENT TEST)

The module/s must be first be subjected to an I_n test impulse as described in IEC 61643-1. The Test current I_n is 10kA 8x20uSec. The Clamping voltage measured 150 mm (6 in.) from the module/s connection is then recorded and the current waveform plotted.

7.10.2.3 COMPONENT SURGE TEST CALIBRATION

The surge generator must be calibrated to the test current and the current waveform plotted as per UL 1449 2nd Edition. Calibration should be performed with the actual lead wires used to connect the module/s. This will allow the delivered current to closely match the short circuit current. Calibration for the SAD module/s **shall** be 20 kA. Calibration for the MOV module/s **shall** be 160 kA. No AC is required for this test. The clamping voltage measurement is not required for this test.

7.10.2.4 MODULE(S) TESTING

The SAD module(s) are then subjected to the 20 kA impulse.
The MOV module(s) are then subjected to the 160 kA impulse.

7.10.2.5 PASS CRITERIA

The modules are then subjected to the I_n 10 kA test as described in paragraph 7.10.2.2. The VPL is then measured and recorded. The current/voltage waveform is plotted. The Pre-test I_n VPL is compared to the post-Test I_n VPL. The modules passes the requirement if the post VPL is within 10% of the Pre VPL.

7.10.3 IMPULSE SURGE DURABILITY TEST REQUIREMENTS

7.10.3.1 GENERAL

The impulse surge durability test is designed to test the endurance of the SPD. Each Type of SPD is subjected to it's own set of impulses. For Type 1 and 2 devices the SPD is first subjected to a pre-test I_n impulse and it's VPL is measured and recorded. After the Duty cycle testing the SPD is again subjected to an I_n impulse and it's VPL is measured and recorded. The Post I_n VPL must be within 10% of the Pre I_n VPL. All referenced surge currents are based on 8X20 uSec waveforms except for the 100 kHz ringwave. The total number of impulses for each type is 400. Two hundred (200) impulses **shall** be applied positive at a phase angle of 90° ($+0^\circ, -15^\circ$) and 200 impulses **shall** be applied negative at a phase angle of 90° ($+0^\circ, -15^\circ$).

7.10.3.2 I_n PRE-TEST (NOMINAL CURRENT TEST)

The SPD must be first be subjected to an I_n test impulse as described in IEC 61643-1. The Test current I_n is 10 kA 8x20uSec. The Clamping voltage measured 150 mm (6 in.) outside of the enclosure is then recorded and the current and voltage waveform plotted.

7.10.3.3 DUTY CYCLE CALIBRATION

The surge generator **shall** be calibrated as specified in UL 1449, 2nd Edition, subsection 34.5. Tolerances and waveform are described in UL 1449, 2nd Edition section 34.5. This test is for Type 1, and 2 SPDs only. For Type 1 SPDs a Calibration of 6 kV, 3 kA and 6 kV, 10 kA is required. For Type 2 SPDs a calibration of 6 kV, 3 kA is required. All calibration current waveforms must be measured and plotted.

7.10.3.4 SPD DUTY CYCLE TEST

Type 1 SPDs, the test voltage and current **shall** be a combination of pulses at 6 kVp minimum at 3 kA and 6 kVp minimum at 10 kA. This test **shall** consist of 20 impulses at 6 kVp minimum / 10 kA, followed by 160 impulses at 6 kVp / 3 kA, followed by 20 impulses at 6 kVp minimum/ 10 kA respectively per polarity. The surges **shall** be conducted in succession with a maximum 60 second period between each surge. The total number of impulses being 400.

Type 2 SPDs, the test voltage and current **shall** be a combination of pulses at 6 kVp minimum at 3 kA. This test **shall** consist of 400 impulses at 6 kVp minimum/ 3 kA. The surges **shall** be conducted in succession, with a maximum 60 second period between each surge. The total number of impulses being 400.

Type 3 SPDs, the test voltage and current, **shall** be 6 kVp at 200 A, and 100 kHz (ringwave test) as described by IEEE C62.41. This test **shall** consist of 400 impulses conducted in succession with a maximum 60 second period between each surge.

7.10.3.5 PASS CRITERIA

After Duty Cycle testing, the SPD is then allowed to cool to room temperature. The SPD is then subjected to the In 10 kA test as described in 7.10.2.2 on page 7-48. The VPL is measured and recorded. The current and Voltage waveform is plotted. The Pre-test In VPL is compared to the post-Test In VPL. The SPD passes the requirement if the post VPL is within 10% of the Pre VPL. For Type 3 devices if the SPD remains fully functional the unit passes.

7.10.4 MAXIMUM DISCHARGE CURRENT TEST

7.10.4.1 GENERAL

The Maximum Discharge Current test is designed to test the maximum surge capability of the SPD. Maximum Discharge Current, I_{max} , for Class II Test - Crest value of a current through the SPD having an 8/20 waveshape and magnitude according to the test sequence of the Class II operating duty test. I_{max} for Type 1 and Type 2 SPDs is 160 kA. The SPD **shall** be mounted and connected as per the manufacturer's installation instructions.

If manufacturer provides electrical conductors as a part of the product, testing and measurements **shall** be conducted on the full length of conductor provided

If no electrical conductors are provided, testing and measurements **shall** be conducted at the terminal block

Testing **shall** be performed in free air, 20 °C, ± 15 °C.

During the testing, maintenance or modifications **shall not** be performed.

All referenced surge currents are based on 8 × 20 uSec waveforms.

7.10.4.2 IN PRE-TEST (I NOMINAL CURRENT TEST)

The SPD must be first be subjected to an In test impulse as described in IEC 61643-1. The Test current In is 10 kA 8x20uSec. The clamping voltage measured 150 mm (6 in.) outside of the enclosure. The VPL is then recorded and the current and voltage waveform plotted.

7.10.4.3 I_{MAX} SURGE GENERATOR CALIBRATION

The surge generator **shall** be calibrated as specified in UL 1449, Second Edition sub section 34.5. Tolerances and waveform are described in UL 1449, 2nd Edition section 34.5. This test is for Type 1, and 2 SPDs only. Calibration should be performed with the actual lead wires used to connect the module/s. This will allow the delivered current to closely match the short circuit current.

1. Calibrate the Surge Generator with an 8/20 msec short circuit current of 16 kA. Denote and record the charge voltage of the surge generator. Measure, record and plot the short circuit current including peak amplitude, rise time and duration.
2. Calibrate the Surge Generator with an 8/20 msec short circuit current of 40 kA. Denote and record the charge voltage of the surge generator. Measure, record and plot the short circuit current including peak amplitude, rise time and duration.
3. Calibrate the Surge Generator an 8/20 msec short circuit current of 80 kA. Denote and record the charge voltage of the surge generator. Measure, record and plot the short circuit current including peak amplitude, rise time and duration.
4. Calibrate the Surge Generator with an 8/20 msec short circuit current of 120 kA. Denote and record the charge voltage of the surge generator. Measure, record and plot the short circuit current including peak amplitude, rise time and duration.
5. Calibrate the Surge Generator with an 8/20 msec short circuit current of I_{max} 160 kA. Denote and record the charge voltage of the surge generator. Measure, record and plot the short circuit current including peak amplitude, rise time and duration.

7.10.4.4 I_{MAX} DISCHARGE TEST

Connect the Positive Terminal of the Surge Generator to the L1 terminal or conductor of the SPD.

Connect the Negative Terminal of the Surge Generator to the N terminal or conductor of the SPD.

1. Apply a surge current of 16 kA with a positive polarity, no AC applied. Measure, record and plot the delivered current.
2. Apply a surge current of 40 kA with a positive polarity, no AC applied. Measure, record and plot the delivered current.
3. Apply a surge current of 80 kA with a positive polarity, no AC applied. Measure, record and plot the delivered current.
4. Apply a surge current of 120 kA with a positive polarity, no AC applied. Measure, record and plot the delivered current.
5. Apply a surge current of I_{max} 160 kA with a positive polarity, no AC applied. Measure, record and plot the delivered current.
6. Repeat Steps 1 through 5 above for the remaining modes of protection of the SPD.
7. Apply thermocouples to the top and two-sides of the SPD.
8. Connect the SPD to the voltage, phase and power circuit configuration as detailed on the data label.
9. Energize the SPD for a period of 30 minutes. Measure and record the temperatures obtained.

7.10.4.5 PASS CRITERIA

After I_{max} testing the SPD is allowed to cool to room temperature. The SPD is then subjected to the In 10 kA post-test as described in “ I_N (Nominal Current Test)” on page 7-48. The VPL is measured and recorded. The current and Voltage waveform is plotted. The Pre-test In VPL is compared to the post-Test In VPL. The SPD passes the requirement if the post VPL is within 10% of the Pre VPL.

During the Residual Voltage Measurement, Pre-conditioning and I_{max} Operating Duty Cycle Tests, the following conditions **shall not** occur:

- Emission of flame, molten metal, glowing or flaming particles through any openings (pre-existing or created as a result of the test) in the product.
- Ignition of the enclosure.
- Creation of any openings in the enclosure that results in accessibility of live parts.
- Opening, temporary, or permanent, of over-current protective components.
- Errors resulting from a failure, temporary, or permanent, in the indication circuitry
- A supplementary protection device opening.

MINIMIZING SITE INTERFERENCE

This chapter provides information on preventing radio frequency (RF) interference at a communications site. The following topics are included:

- “Interference Protection Recommendations” on page 8-1
- “General Site Environmental Requirements” on page 8-3
- “Other Band Architecture—Overview” on page 8-4
- “Mitigating External Intermodulation and Transmitter Noise / Receiver Desense Interference” on page 8-8

This chapter describes the minimum filtering and techniques that should be applied at any fixed site to minimize interference. These techniques should be used by a site manager or carrier to define the minimum essential elements to achieve successful operation. Implementation of these requirements will help provide an environment for successful operation and future expansion.

The requirements defined in this chapter pertain to eliminating interference, and are separate from the RF Engineering design of the site.

8.1 INTERFERENCE PROTECTION RECOMMENDATIONS

Unlike mobile units that can be moved to an interference-free area, fixed sites must incorporate equipment and techniques to reduce the likelihood of interference. The ability to successfully receive the desired radio signal at the fixed receiver is dependent upon providing the best possible radio frequency environment at the site. To accomplish this, the level of undesirable energy occurring on the received frequency must be minimized. In most cases, minimizing the level of undesirable energy emitted by the local transmitters and filtering out undesirable signals coming into the receiver eliminates received interference in the receiver environment. Interference is more likely to be a problem at sites with multiple antennas. If these measures have been taken and the receiver is still picking up noise, then noise sources in the surrounding environment must be identified and eliminated.

A successful communication site should have standards that are applied to all users of the site and recommended to other communications sites in the general vicinity. Another site within a 400 m (1/4 mile) radius may interfere with your site or may receive interference from your site unless protective equipment and techniques are used.

The techniques described in this section have a history of successful implementation, and are not specific to any particular radio or filter vendor. The protective equipment to be used is available from numerous vendors that have met Motorola’s criteria for product performance, reliability, and support. Contact the local Motorola Engineering team for additional details.

Transmitter noise, receiver desensitization and unwanted intermodulation caused by objects in the site environment are the most common causes of receiver interference. Other common interference terms are Co-Channel and Adjacent Channel interference. Some analysis of the existing or proposed frequencies at an antenna site can help in the site design process. Requirements for preventing problems in each of these areas are described below.

8.1.1 MINIMUM TRANSMITTER PROTECTION REQUIREMENTS

A properly designed site will incorporate several techniques to reduce the likelihood of the transmitters causing interference to a receiver signal. Each transmitter should have an isolator, low pass filter and bandpass cavity setup. The number of isolators and bandpass cavities needed for a transmitter to achieve proper filtering is dependent upon the transmitter equipment and frequencies at the communication site and other transmission sites in the local area. If additional help is needed to determine these requirements, contact the local Motorola Engineering team for additional support.

An isolator is used on a transmitter to reduce the amount of radio energy, which is coming back into the final amplifier stage from the antenna system. This action in turn reduces the undesirable signal levels of other radio signals coming back into the final amplifier stage and helps to prevent a mixing of two or more different frequencies within the non-linear device. The mixing process is called transmitter intermodulation and it can generate interfering frequencies for receivers. In some situations, the isolator can produce second harmonic spurious emissions, which are also harmful to receiver reception. To protect against this a low pass filter should be used between isolator stage and the antenna system.

A bandpass cavity is a high Q resonant circuit, which is designed to pass a narrow band of frequencies with very little energy loss while attenuating all other non-resonant frequencies. Bandpass cavities should be installed between the transmitter and antenna system to reduce spurious signals and transmitter sideband noise that might otherwise be radiated from the transmitter and degrade the performance of nearby receivers. The use of a bandpass cavity will also reduce and minimize transmitter intermodulation since all off-frequency signals from other nearby transmitters will be attenuated as they pass through the cavity.

For successful operations and future expansion of the site, the following recommendations should be considered when installing transmitters within the following frequency bands. See Figure 8-1 for proper configuration of the recommended filtering devices.

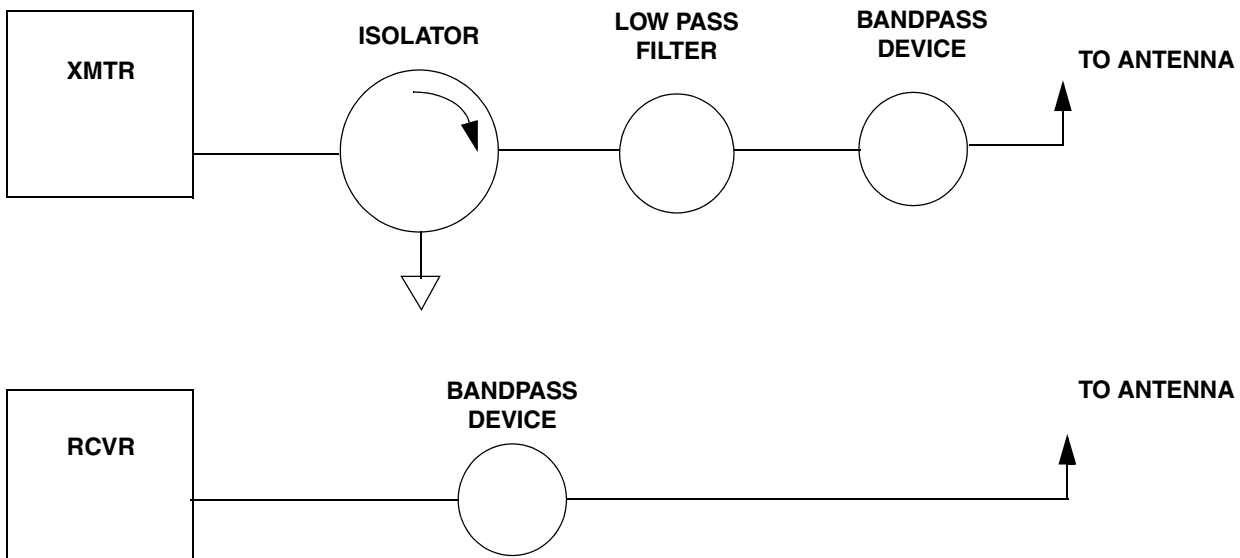

FIGURE 8-1 CONFIGURATION OF FILTERING DEVICES

25-54 MHz - Transmitters in this range **shall** have an isolator with a minimum of 20dB reverse isolation followed by a low pass filter and a bandpass cavity setup, which provides a minimum of 20dB of attenuation at 1 MHz from the transmit frequency.

66-88 MHz - Transmitters in this range **shall** have an isolator with a minimum of 25dB reverse isolation followed by a low pass filter and bandpass cavity setup, which provides a minimum of 20dB of attenuation at 1 MHz from the transmit frequency.

130-225 MHz - Transmitters in this range **shall** have a set of isolators with a minimum of 50dB reverse isolation followed by a low pass filter and a bandpass cavity setup, which provides a minimum of 25dB of attenuation at 1 MHz from the transmit frequency.

276-284 MHz - Transmitters in this range **shall** have a set of isolators with a minimum of 50dB reverse isolation followed by a low pass filter and a bandpass cavity setup, which provides a minimum of 25dB of attenuation at 1 MHz from the transmit frequency.

400-512 MHz - Transmitters in this range **shall** have a set of isolators with a minimum of 50dB reverse isolation followed by a low pass filter and a bandpass cavity setup, which provides a minimum of 15dB of attenuation at 1 MHz from the transmit frequency.

764-960 MHz - Transmitters in this range **shall** have a set of isolators with a minimum of 50dB reverse isolation followed by a low pass filter and a bandpass cavity setup, which provides a minimum of 15dB of attenuation at 1 MHz from the transmit frequency.

8.1.2 MINIMUM RECEIVER PROTECTION REQUIREMENT

A properly designed fixed site will require that each receiver input be connected to a crystal filter, window filter and/or bandpass cavity to minimize or eliminate receiver desensitization. These devices will create a narrow band window to allow only the desired receive signal to enter the receiver. If the interference is very close in frequency to the receiver frequency, a dual or triple bandpass cavity setup or notch filter may be required. This is normally a less costly and more permanent option to moving the receiver antenna to an alternate location. If additional support is necessary contact the local Motorola Engineering team.

8.2 GENERAL SITE ENVIRONMENTAL REQUIREMENTS

A properly designed communication site uses the following preventive measures to minimize and eliminate locations where radio signals can mix and create intermodulation frequencies or broadband noise.

- Rust - All materials must be free of rust.
- Braided wire **shall not** be used because it can corrode and cause intermodulation signals.
- Rigid metal connections - Metal to metal connections must be rigid.
- All loose metal should be removed from the site.
- Fencing - Chain link type fence material should be vinyl clad.

- Dissimilar metals - Connection of dissimilar metals should only be made after reviewing section 4.5.2, “Galvanic Corrosion” on page 4-36. for each metal. The connections must be rigid and tight.
- Cable ties – Bare metallic cable ties **shall not** be used unless they are stainless steel.
- Power line insulators (glass type) – Cracked insulators are a very likely source of broadband noise. If broadband noise cannot be eliminated by implementing the above recommendations, contact the local utility company and ask them to perform a noise sweep of the general area.

8.3 OTHER BAND ARCHITECTURE—OVERVIEW

Some additional RF site design techniques are required to mitigate radio frequency interference for sites utilizing frequencies below 700 MHz. This is typically referred to as Other Band Architecture (OBA) and may include trunking, conventional, data, and paging systems.

With the limited number of frequencies available in the 800 MHz and 900 MHz bands, expansion into other bands is occurring. The 450 MHz and 150 MHz bands are being utilized for trunking. This utilization of older bands has introduced multi-carrier operation in bands that were originally used primarily for single carrier or limited multi-carrier. Understanding the interference obstacles within these bands requires different solutions than those used at 700 MHz and above.

8.3.1 SPECTRUM USAGE HISTORY

The 700 MHz, 800 MHz and 900 MHz frequency spectrum was coordinated to facilitate combining and trunking system design. These frequency band plans facilitate the use of multiple transmitters connected to a single antenna, as well as receivers connected to a single receive antenna. This allows for the use of standard combining and multicoupling schemes. These bands are divided by a defined spacing between the transmit and receive channel pairs. (45 MHz for 800 MHz, 39 MHz for 900 MHz and 30 MHz for 700 MHz). This spacing helps isolate the intermodulation interference that occurs when two or more frequencies mix in non-linear devices, producing carriers on the existing receiver frequencies.

The VHF and UHF bands were not organized with the same standards as the 700 MHz, 800 MHz and 900 MHz bands. Therefore standard combining and multicoupling schemes cannot be utilized and extensive frequency planning must occur within the system design. These items alone can add significant design time and cost to a project. The UHF and VHF frequency bands have far less immunity to interference because the spacing between transmit and receive channels is not a defined constant. The result can be catastrophic interference if systems are not properly designed. Thus interference will have an effect on sites with OBA systems if not properly addressed.

8.3.2 FORMS OF INTERFERENCE

Interference can have many sources. All forms of interference must be monitored regularly for reliable communication. Interference is normally classified as internal or external. Internal interference is generated within the components of the system. External interference is generated externally and radiated into the affected system. External interference can be prevented with good radio system design practices. All external interference must be eliminated at the source.

Examples of interference include internal and external intermodulation (IM), transmitter sideband noise (TN), receiver desensitization (RD), Co-channel interference and passive intermodulation (PIM). These are briefly described below.

- **IM:** normally caused locally within the system or on site. This form of interference is caused by the mixing of multiple transmitters producing an on frequency carrier.
 - Internal IM is generated within system components. This can occur within the transmitter power amplifier, within the transmitter combining isolator and within the receiver, when strong off-frequency signals are allowed to enter the front end of the receiver and mix.
 - External IM is generated external to the transmitter or receiver system components. This interference can be produced in non-linear components on the site. Rusty tower joints, rusty fences, guy wires, corroded connectors, and inadequate grounding can also be sources of intermodulation. In all cases the only solution for external intermodulation is to find the source and eliminate it.
- **Transmitter Sideband Noise:** All transmitters emit some noise. Transmitters should have bandpass filtering added to reduce this noise and protect collocated receivers.
- **Receiver Desensitization:** - A receiver's ability to process weaker signals is reduced by the influence of a strong signal occurring on a closely spaced channel. Unlike the other types of interference, there are no audible indications of interference; There is only a reduction in receiver sensitivity.
- **Co-channel:** Multiple transmitters within the same coverage area assigned the same frequency.
- **Adjacent Channel:** Interference from users on a frequency assignment next to the operating frequency is adjacent channel interference.
- **PIM:** Another type of intermodulation, evident in non-active (thus passive) system components. Common mixing points are connectors, cables, surge protectors, combiners and antennas. Use of high quality (PIM rated) components can mitigate these issues.

8.3.3 OBA INTERFERENCE MITIGATION

When designing a new system utilizing OBA frequencies the following items should be considered and practiced:

- Frequency Layout
- Create Band Plan (Specific Tx/Rx Pairs)
- Perform Intermodulation Analysis
- Perform TN / RD Analysis
- Antenna Network Components PIM analysis and PIM sourcing
- Optimization / Testing
- RF Maintenance

Each of these items is discussed in more detail below.

8.3.3.1 DOCUMENT FREQUENCY LAYOUT

All available frequencies that may be used, as well as those already in use, should be defined and documented. Therefore a thorough “frequency inventory” should be performed consisting of the following activities:

- Collect/search for available frequencies.
- Conduct site audits of existing frequencies used on site.
- Document existing user antenna locations as an aid in the antenna/combining design.

8.3.3.2 CREATE A BAND PLAN

After all frequencies have been identified, create a band plan for specific transmit/receive pairs. The following tasks should be performed:

- Arrange frequencies in contiguous transmit and receive blocks to create guard bands.
- Create the band plan (specific transmit/receive pairs).
- Minimize implicit band plan elements used for system expansion (maximum of 16 elements).
- Maximize guard bands between transmit frequency blocks and receive frequency blocks.
- Maximize transmit/receive frequency separation for each channel to help control combining size and cost.
- Assign channel pairs to sites.
- Avoid narrow separations from existing frequencies on site whenever possible. This helps keep combining size/cost down.

8.3.3.3 PERFORM INTERMODULATION ANALYSIS

Intermodulation (IM) products are generated whenever two or more frequencies mix together at a radio site. Under the worst adverse conditions, the reception of the desired on-channel frequency can be suppressed by the FM capture effect of stronger undesired IM products. If the intensity of the IM product is lower than that of the desired signal it can still cause audible interference during periods in which the affected channel is not in use.

An IM study can help detect interference products and the root frequencies that can mix to cause interference. Motorola Engineering can perform the intermodulation analysis. The following guidelines apply when working with the IM analysis results:

- Run third, fifth, and seventh order IM.
- Determine PIM risk and design.
- Avoid third-order IM within a single combiner.
- Avoid third-order IM on site or tower if possible.
- Avoid fifth- or seventh-order IM within combiner.

8.3.3.4 PERFORM TRANSMITTER NOISE / RECEIVER DESENSE ANALYSIS

Systems affected by Transmitter Noise/Receiver Desense (TN/RD) conditions will show signs of reduced radio coverage. A TN/RD analysis can provide the information needed to determine what two-way radio systems, whether existing or planned, have the potential to cause interference. This knowledge will help systems engineers select equipment needed to correct or prevent interference.

Motorola Engineering can perform the TN/RD analysis. The following guidelines apply when working with the

TN/RD analysis results:

- Design for all frequencies on site, not just customer frequencies.
- Transmitter Combiner Network:
 - 45 dB minimum selectivity at each Guard Band plus 45 dB minimum transmit-to-receive antenna isolation (90 dB total)
 - Insertion loss balanced within 4.5 dB across ports
 - 6 channel ports or fewer on each combiner
 - 90-100 kHz minimum Tx-to-Tx frequency separation
 - Install second Tx antenna to mitigate third-order IM
 - Use greater vertical separation between transmit and receive antennas to mitigate fifth- and seventh-order IM risk. 6 vertical metres (20 vertical feet) provides 55 dB isolation.
- Receiver Multicoupler Network:
 - 65 dB minimum selectivity at each Guard Band plus 45 dB minimum transmit-to-receive antenna isolation (110 dB total)
 - 15 dB reserve gain available
 - 45 dB third-order Intercept Point in Amplifier
 - < 2 dB noise figure in Amplifier
 - Use greater vertical separation between transmit and receive antennas to mitigate fifth- and seventh-order IM risk. 6 vertical metres (20 vertical feet) provides 55 dB isolation.

8.3.4 ANTENNA NETWORK COMPONENTS

Follow these Best Practices during design when selecting antenna network components:

- Always use PIM rated components, including antennas and combiners with PIM specifications.
- Use 7/16 inch DIN connectors on all transmit network components.
- Superflex cable from combiner output to transmit antennas **shall not** be used.
- Follow mounting recommendations:
 - Try to mount transmit antennas on top of tower.
 - Mount transmit antennas as far apart as possible.
 - Mount transmit antennas on different mounting structures.
 - Mount antennas as far from tower as possible.
 - Mount the receive antenna as far from the transmit antenna as possible.

- Use proper torque on all connectors.
- Cables should be continuous with as few connections, jumpers, and adapters as possible.
- Clean all connections before assembly/re-assembly.

8.3.5 OPTIMIZATION AND TESTING

When installing a new system, the following should be performed and documented:

- Measure Effective Receiver Sensitivity (ERS) on the receivers.
- Measure TN / RD degradation from **all** transmitters on site.
- Perform Frequency Domain Reflectometer (FDR) testing on antenna systems, verifying all installed components meet the manufacturer's specifications.

8.3.6 MAINTENANCE

Throughout the life of a system, the following should be considered for system maintenance:

- Frequency changes should be considered a redesign.
- Frequency additions to site must be monitored.
- Interference degradation must be monitored with periodic effective receiver sensitivity (ERS) tests.
- Perform periodic Frequency Domain Reflectometer (FDR) testing on antenna systems, verifying the antenna system has not degraded from original installation testing (commissioning).

8.4 MITIGATING EXTERNAL INTERMODULATION AND TRANSMITTER NOISE / RECEIVER DESENSE INTERFERENCE

Motorola is providing general guidelines to mitigate the effects of interference caused by intermodulation and Transmitter Noise / Receiver Desense (TN/RD) from the existing user community. Some general guidelines are provided below for each type of external interference. Motorola Engineering can assist in mitigation of external IM and TN / RD interference problems.

In most cases, minimizing the level of undesirable energy emitted by the local transmitters and filtering out undesirable signals coming into the receiver eliminates received interference in the receiver environment. Interference is more likely to be a problem at sites with multiple antennas.

8.4.1 INTERMODULATION

Every transmitter on site **shall** be equipped with a dual-stage isolator with second harmonic filter or bandpass cavity on the isolator output. Strong IM can be generated from the transmitter power amplifier (PA). The dual-stage isolator greatly reduces the amount of external frequency energy entering a transmitter PA and consequently, the level of IM generated. The radio site must be clear of any dissimilar metal connections, rusty metallic areas, rusty fence building and tower bolts, loose guy wires, etc. Much of the R56 site improvements are helpful to reduce or eliminate these sources where multiple frequencies mix to produce intermodulation products. Jacketed heliax transmission lines and type N connectors **shall** be used instead of RG-8 cable and UHF connectors. Where two or more transmit frequencies are combined to one antenna, connectors **shall** be 7/16 inch DIN connectors. Type N connectors have been found to be a mixing point source of IM products.

Every receiver should have a band pass cavity to prevent strong transmitter signals from swamping the receiver, then mixing to form IM products that are generated from a base station's receiver. Transmit antenna and receive antenna isolation is helpful to prevent harmful interference from IM products. A good rule of thumb is to have a transmit to receive antenna isolation of at least 45 dB. This is achieved by mounting the tip of the lower antenna 3 m (10 ft.) vertically below the base of the upper antenna. The idea is to reduce the level of IM reaching any given receiver. Because tower space is limited, the best way to achieve this for all users on site is to develop a master combining system where the receive antenna(s) occupy a defined receive-only zone on the tower, while transmit antenna(s) occupy a defined transmit-only zone. The receive and transmit antennas are separated by at least 3 vertical metres (10 vertical feet) to provide 45 dB of isolation. The more vertical separation between transmit and receive antenna, the better the isolation obtained. For example, 6 m (20 ft.) of vertical separation provides 55 dB of antenna isolation.

8.4.2 TRANSMITTER NOISE/RECEIVER DESENSE

All transmitters onsite should have sufficient transmitter noise filtering to reduce harmful on-channel noise to all receivers on site. This is best achieved through a bandpass cavity(s) that reduces the on-channel transmitter noise below the interference level. Transmitter noise problems are on-channel to a receiver frequency, therefore, transmitter noise problems must be addressed at the source. A good rule of thumb is for each transmitter to reduce its sideband noise by approximately 90 dB. This number varies depending on the particular base station model and make. If transmit antennas are spaced at least 3 vertical metres (10 vertical feet) from receive antennas, this means only 45 dB of transmit noise bandpass cavity suppression is needed, as the antenna separation achieves 45 dB isolation.

All receivers should have bandpass cavities to prevent receivers from being desensitized by nearby strong transmit frequency carriers. A good rule of thumb is to provide sufficient filtering to the 110 dB level. This number will vary depending on the model and make of the base station. Receive antenna to transmit antenna isolation of at least 45 db, achieved by 3 m (10 ft.) of vertical separation, is recommended. This reduces the amount of receiver band pass cavity filtering required by 65 dB. Because tower space is limited, the best way to achieve this for all users on site is to develop a master combining system where the receive antenna(s) occupy a defined receive-only zone on the tower, while transmit antenna(s) occupy a defined transmit-only zone. The receive and transmit antennas are separated by at least 3 vertical metres (10 vertical feet) to provide 45 dB of isolation. For example, 6 m (20 ft.) of vertical separation provides 55 dB of antenna isolation.

8.4.3 SIMPLEX MULTI-FREQUENCY STATIONS

Simplex multi-frequency stations cannot be combined or even have cavities installed on them. Because cavity filters are tuned to operate at one frequency, they cannot be used on multi-frequency stations. These types of stations must be evaluated carefully on a case by case basis because there is little that can be done to mitigate any interference involving them.

EQUIPMENT INSTALLATION

This chapter includes the following topics:

- “Facility Readiness” on page 9-1
- “General Considerations for Layout, Work Areas, and Spacing” on page 9-2
- “Seismic Considerations” on page 9-3
- “Equipment Mounting Plumb and Squareness” on page 9-5
- “Equipment Anchoring” on page 9-5
- “Equipment Installation Within Racks or Cabinets” on page 9-10
- “Ancillary Equipment Mounting” on page 9-10
- “Equipment Cabling” on page 9-11
- “Electrostatic Discharge Considerations” on page 9-31

9.1 INTRODUCTION

This chapter describes requirements and standard methods for communications equipment installation.

NOTE: The requirements described in this chapter **shall** be met before communications equipment is installed in site.

NOTE: This chapter assumes that all site and structure preparations have been performed (including battery systems, generators, line transient voltage suppression systems, tower systems, and site/structure grounding systems).

9.2 FACILITY READINESS

Following all construction work, both exterior and interior, the site and facility (structure or shelter) **shall** be in a suitable condition for installation of communication equipment. In general, the following considerations must be observed:

- Shelter exterior **shall** have final backfill and grade.
- Path between shelter and access road **shall** be free of trackable debris.
- Interior of facility **shall** be free of excessive dust or debris.
- Site exterior area **shall** have all refuse related to the installation tasks described in this manual removed before occupancy.

9.3 GENERAL CONSIDERATIONS FOR LAYOUT, WORK AREAS, AND SPACING

Consideration should be exercised when laying out a site to allow primarily for all code requirements for spacing, and then the most efficient use of space. Special attention **shall** be given to future expansion with regard to cable runway heights, electrical outlet placement, and equipment placement. Figure 9-1 shows proper equipment layout.

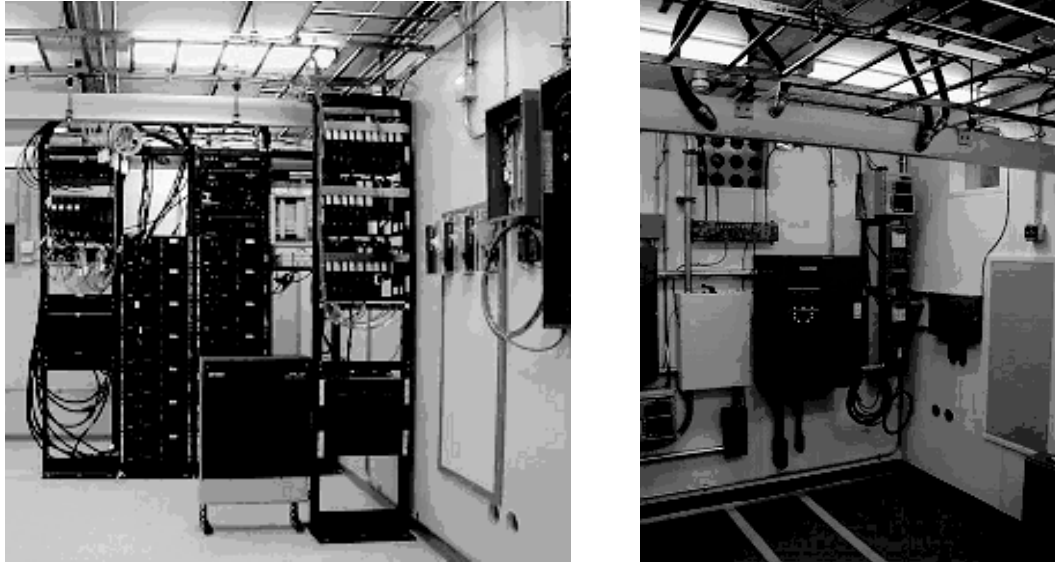

FIGURE 9-1 TYPICAL SITE INSTALLATION SHOWING PROPER EQUIPMENT LAYOUTS

9.3.1 SPACING REQUIREMENTS

Proper spacing of equipment is essential for efficient use of the room area, ease of maintenance, and safety of personnel. The following specifications have been established to meet the National Fire Protection Associations (NFPA) Code, and the American Society of Heating, Refrigerating, and Air Conditioning Engineers (ASHRAE) standards. Any local regulations, as applicable, **shall** also be adhered to.

- To provide adequate working space, a 0.37 m^2 (576 sq in.) footprint (as measured from facing equipment surfaces) **shall** be used for combining equipment and upright base station equipment.

NOTE: Local codes may require additional clearance than stated above. In such cases, the local code **shall** prevail.

- A 914 mm (36 in.) side aisle **shall** be maintained around electrical panel boards (NFPA 70-2005, Article 110.26).
- A 914 mm to 1.2 m (36 to 48 in.) front, side, and (where applicable) rear aisles are required for servicing interior mounted air conditioners (NFPA 70-2005, Article 110.26, ASHRAE).

- A 762 mm (30 in.) aisle **shall** be maintained in front of all telephone switching equipment and/or demarcation cabling. A 914 mm (36 in.) aisle **shall** be maintained in situations where there is telephone switching equipment and/or demarcation cabling on both sides of the aisle (NFPA 70-2005, Article 110.72).
- A 762 mm (30 in.) minimum workspace **shall** be maintained on all non-egress or aisle ways without equipment described in this section.
- A 914 mm (36 in.) aisle **shall** be maintained between at least one end of an equipment row and building wall or other obstruction; longer aisles may require additional access breaks. Larger aisles and additional access breaks in a row may be required as the row becomes longer, such that a fire in the aisle does not prevent egress. Comply with any codes regarding fire egress specifications.
- Ingress and egress to equipment rooms **shall** conform with NFPA 70-2005 Article 110 and local building and fire codes.
- In US installations where a facility is to be normally occupied, American with Disabilities Act (ADA) **shall** be complied with. Some general requirements of ADA are 914 mm (36 in.) wide doors, ramps and safety rails, 914 mm (36 in.) turn-around clearance for wheelchairs, and specific placement of telephones, fire extinguishers, light switches, etc. Note that ADA compliance in architectural plans may be required in obtaining a construction permit in some localities.

9.4 SEISMIC CONSIDERATIONS

Site protection from earthquakes may be required in certain areas. Typically, this would be an area having historical data indicating a Moment Magnitude rating of 3 or 4. Note that areas other than historically prone areas may need consideration. Obviously, addressing such concerns results in increased costs of equipment installation.

A certified architect specializing in earthquake-resistant installation **shall** be consulted for seismic designs and recommendations in areas where the potential loss of the site may outweigh associated costs of earthquake-resistant design. In the United States, it is recommended to consult the US Geological Survey for additional information regarding earthquake probability and historical data for various areas. In other areas, similar consultation should be done.

NOTE: US Geological Survey information can be accessed at <http://geohazards.cr.usgs.gov>
Seismic maps are available at: <http://www.neic.cr.usgs.gov/>

9.4.1 GENERAL RECOMMENDATIONS

Earthquake-resistant design should be contracted to a firm specializing in such work. Follow the design recommendations of the seismic engineering firm. In other cases observe the following general considerations:

- Equipment **shall not** be secured to both the shelter walls and floors, because dissimilar movement between these surfaces is likely in an earthquake.

- Mounting should provide for some “sway” in the overall equipment mounting, thereby absorbing the energy of an earthquake. This is typically accomplished by rigid mounting of racked equipment or cabinets at the base, while semi-rigidly attaching the rack top using 3.2 mm (0.125 in.) diameter steel braided wire rope. Wire rope anchors are then secured to ceilings joists. The benefit of this type of installation is that racks are allowed to sway within limits but can't fall over. Cables and transmission lines **shall** be installed to allow the equipment rack to sway.
- Cabinet designs with wide footprints can be used to help prevent cabinets from tipping over.
- Columns of cabinets stacked and bolted back-to-back present a very stable and wide footprint. The bottom cabinets **shall** still, however, be bolted to the floor for complete security.
- Some cabinets can be outfitted with outrigger-type support legs to prevent tip-over. These outriggers alone do not provide adequate earthquake protection, but are typically adequate if the cabinet is bolted to the floor.

NOTE: If a rack is seismic rated, any add-on aftermarket equipment or equipment that is not seismic rated will render the overall package as not being seismic tested and certified as a unit. Therefore, the unit would no longer be considered as seismic rated.

- All ancillary equipment that is not mounted in a rack or cabinet, such as CRTs or control stations, **shall** be securely fastened to a mounting structure.
- When bolting down to raised computer flooring, be sure to anchor all the way to the sub-floor.
- Columns of cabinets must be supported, though **not** rigidly. Rigid mounting will result in extreme vibration and resultant mechanical failure during an earthquake. Semi-rigid mounting is preferred. Semi-rigid bracing is defined as bracing which allows a measurable amount of movement.
- Some raised computer floors lose mechanical integrity if several panels are simultaneously removed. This could lead to equipment floor collapse during an earthquake. The flooring manufacturer **shall** be consulted for floor removal procedures. Raised flooring systems appropriate for the seismic zone **shall** be used.
- Equipment **shall** be stabilized by a top support. This is critical in preventing a column of equipment from toppling, causing injury to personnel. The footings of cabinet columns and racks **shall** be bolted to the floor as appropriate, using concrete anchors. Sometimes the cabinet columns are placed on C-channel tracks or wooden pedestals.
- Lighting fixtures should be prevented from swaying by addition of one or more guy wires. A fluorescent lighting fixture in particular, can be very dangerous if allowed to swing against a wall or equipment racks, shattering and spraying broken glass below. Fluorescent lighting fixtures **shall** have protective lenses or protective plastic sleeves which cover the fluorescent tube, preventing broken glass from falling on occupants.
- Storage cabinets **shall** be secured to prevent upset. Storage cabinets **shall** also have closable, secured doors to prevent contents from spilling during an earthquake.
- Ladders and other large objects **shall** be secured to a wall or removed from the equipment room when not in use. These items have been known to fall into “live” equipment during earthquakes.

9.5 EQUIPMENT MOUNTING PLUMB AND SQUARENESS

- Equipment **shall** be level and plumb. Equipment level **shall** be tested on a known flat surface in at least two directions to verify accuracy.
- Equipment **shall** be parallel or perpendicular to the surrounding walls and adjacent installed equipment.

9.6 EQUIPMENT ANCHORING

Anchoring is the mechanical fastening of the communications equipment to suitable locations using hardware acceptable for the application.

Although every installation is unique, certain methods for anchoring **shall** be adhered to for all installations. Typically, at least four anchor points **shall** be used on each item of equipment mounted to the floor. (The only exception is when the equipment manufacturer supplies other than four mounting points.)

NOTE: Where seismic concerns exist (Moment Magnitude rating 3 or greater), see “Seismic Considerations” on page 9-3 for additional information and requirements.

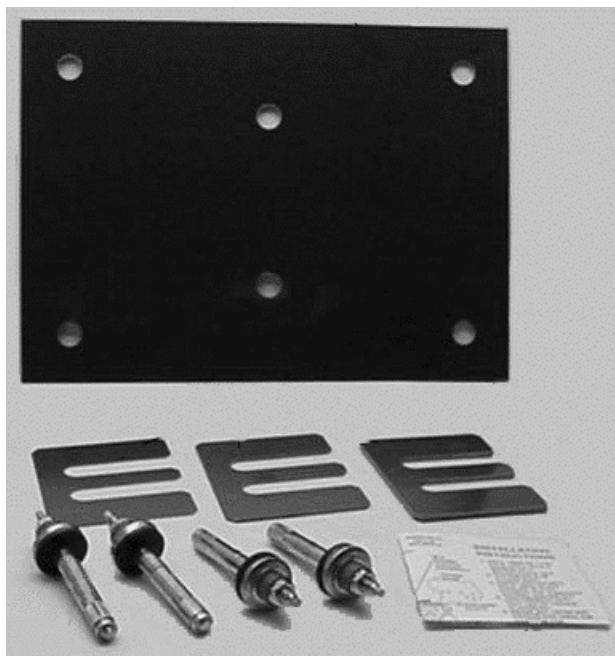

FIGURE 9-2 TYPICAL EQUIPMENT ANCHOR KIT

9.6.1 MOUNTING ON CONCRETE FLOORS

9.6.1.1 GENERAL REQUIREMENTS

Equipment racks or cabinets should be positioned and anchored to the floor using preferred mounting methods. Figure 9-3 on page 9-7 shows proper concrete mounting techniques and materials. In general, observe the following considerations:

- An anchor specifically designed for concrete **shall** be used. The preferred method for anchoring racks, or other ancillary equipment to concrete floors is to use flush-mount expansion anchors properly sized for the application. Flush mount expansion anchors do not extend above the surface of the floor and provide an easy bolt down. They also provide the required pullout and shear strength. If at a later time equipment needs to be moved, flush mount expansion anchors do not get in the way.

NOTE: Unless an isolating mounting scheme is used (see “Isolated Mounting” on page 9-8), ensure that no anchors come in contact with reinforcing rods or wire mesh buried in the concrete; the rack **shall** be electrically isolated from any other equipment or materials at the site.

- In applications where flush mount expansion anchors are not preferred or acceptable, then wedge-type stud anchors may be used.
- All concrete anchors **shall** be zinc plated carbon steel for standard applications, galvanized steel for mildly humid or corrosive environments, and yellow zinc or stainless steel for humid, highly corrosive, or acidic environments. Minimum bolt diameter **shall** be 10 mm (0.375 in.) with 12 mm (0.5 in.) preferred. Anchor embedment depth should be at least 76 mm (3 in.) to provide good tensile and shear strength. Follow manufacturer’s instructions for depth reduction when rebar is encountered. A heavy duty washer should be part of the anchor assembly to ensure the equipment is secure.

9.6.1.2 SEISMIC ANCHORING

Seismic anchors are designed, tested, and specified for seismic zones 3 and 4. The use of seismic anchors enhance the stability of equipment due to the special characteristics specifically suited to the dynamic and cyclic loading effects experienced during earthquake events. As such, anchors **shall** be used that are manufactured to particular specifications that make them the most resistant to the effects of dynamic and cyclic loading effects. Selected anchors **shall** meet standards set forth in NEBS (Network Equipment Building Systems) TR-64 and ASTM (American Society For Testing and Materials) 488-90 for earthquake compliance. This testing evaluates anchors for bolt failure from shearing and from pullout or slippage. Compliance with these standards requires that the anchor not allow a standard top heavy 2.2 m (7 ft.) rack to have a deflection greater than 762 mm (3 in.) at the top of the frame. This compliance will also adhere to Bellcore Technical Specifications AU-434 for earthquake concrete expansion anchors.

Anchor selection criteria **shall** comply with all general requirements for standard concrete anchors plus meet the above seismic requirements. All seismic anchoring **shall** be enhanced with top cabinet or rack bracing.

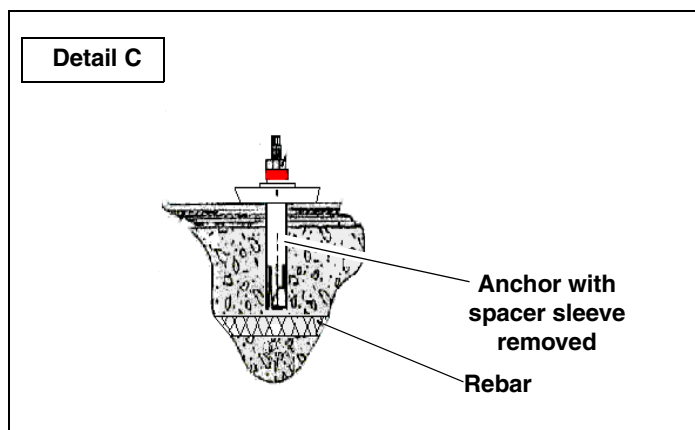
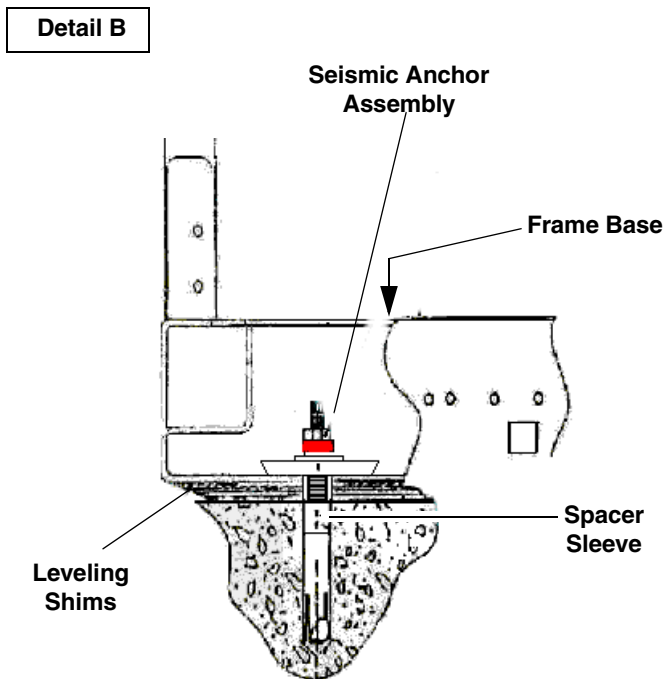
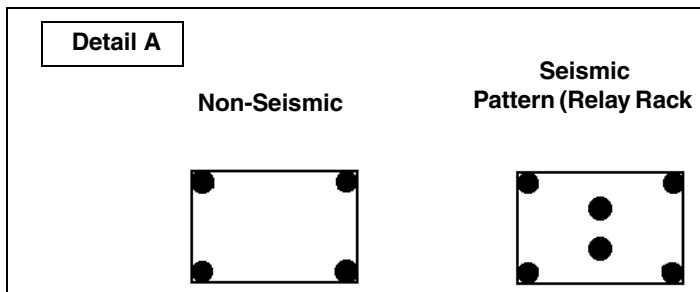

NOTE: For seismic installation, concrete **shall** be a minimum of 206.73 MPa (3000 PSI or 2109.23 Tonnes/m²) rating, at a minimum of 152.4 mm (6 in.) thickness (per Bellcore specification TR-64).

1. (See **Detail A**) Using appropriate pattern, drill 18 mm (11/16 in.) holes. Hole depth **shall** be 102 mm (4 in.) minimum below floor tile.
2. Vacuum all drilling dust, including the drilled holes, with a vacuum equipped with a 0.3 micron HEPA filter or better. Alternatively, place the vacuum outside and extend only the hose into the shelter. If any existing equipment is on site, cover it with an anti-static tarp or covering to prevent dust from entering.
3. (See **Detail B**) Insert anchors into hole until plate washer is flat against floor surface.
4. Tighten anchor nuts to a torque of 67.8 Nm (50 lb ft.).
5. Break nuts loose and remove rods using the 1/4-in drive top.
6. Place cabinet in mounting position.
7. Re-insert threaded rods with stack-up parts into holes. Hand-tighten nuts.
8. Using a wrench, tighten nuts until the tops of torque nuts twist off (between 1/4 and 1/2 turn).
9. If rebar is encountered with the standard anchor, remove the spacer (See **Detail C**). With spacer removed, reinstall the anchor. (Length of threaded rod can be altered, as required.)

FIGURE 9-3 CONCRETE MOUNTING USING CONCRETE ANCHORS

9.6.1.3 ISOLATED MOUNTING

Isolated mounting is recommended to prevent a second path to ground (ground loop) through the concrete floor, and is required for the installation of certain equipment. In these cases, expansion anchors are inserted into the concrete floor. However, isolation of the equipment rack is ensured using an insulating plate and hardware as shown in Figure 9-4. If the installation is in an earthquake zone, additional anchors are used as shown in Figure 9-4.

NOTE: The isolation plate should be made of a insulating material such as fiberglass or polypropylene plastic that will not deteriorate in varied temperature ranges.

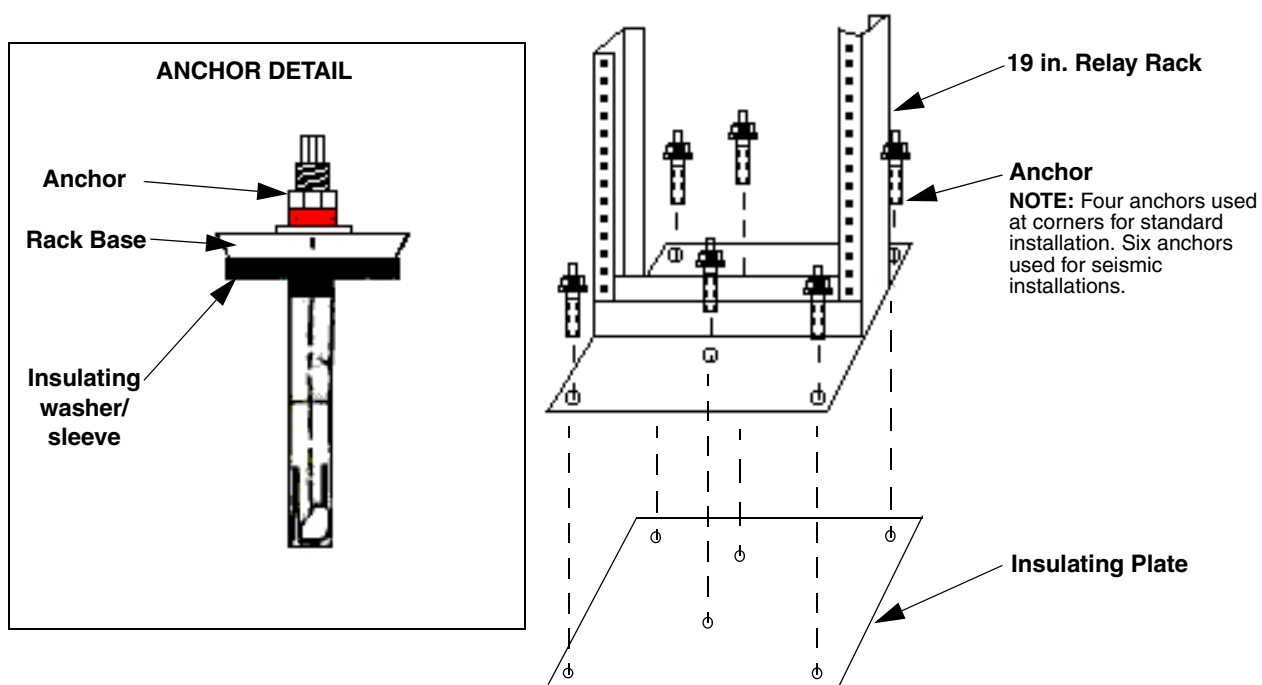

FIGURE 9-4 ISOLATED MOUNTING SYSTEM

9.6.2 MOUNTING ON WOOD OR FIBERGLASS FLOORS

Appropriately sized lag bolts **shall** be used for mounting on wood or fiberglass floors. If the underside is accessible and the floor stability is questionable, then thru-bolting may be desirable.

It is recommend to mount base stations and other non-racked ancillary equipment on a “C-channel” type of mounting track where possible. This provides for easy cleaning and some isolation in the case of standing water. Another benefit of installing non-rack mounted equipment off the floor, is that the weight is distributed across the floor. In these cases, C-channel type mounting provides multiple floor anchor points where the equipment provides only four to six anchor points.

9.6.3 ANCHORING EQUIPMENT TO RAISED FLOORS

At least four anchor points **shall** be used on each item of equipment mounted to the floor. The only exception is when the equipment manufacturer supplies less than four mounting points. When mounting racks to raised floors, 13 mm (0.5 in.) minimum diameter allthread rod and flush mount expansion anchors **shall** be used to anchor to the concrete sub-floor. When mounting equipment to a raised floor, 10 mm (0.375 in.) minimum allthread rod and hardware **shall** be used for anchoring. Mounting arrangement **shall** be in accordance with rack manufacturer's instructions.

Sandwich the computer floor and equipment rack with nuts and washers as shown in Figure 9-5. When mounting consoles to a raised floor, 10 mm (0.375 in.) minimum diameter allthread rod **shall** be used for anchoring.

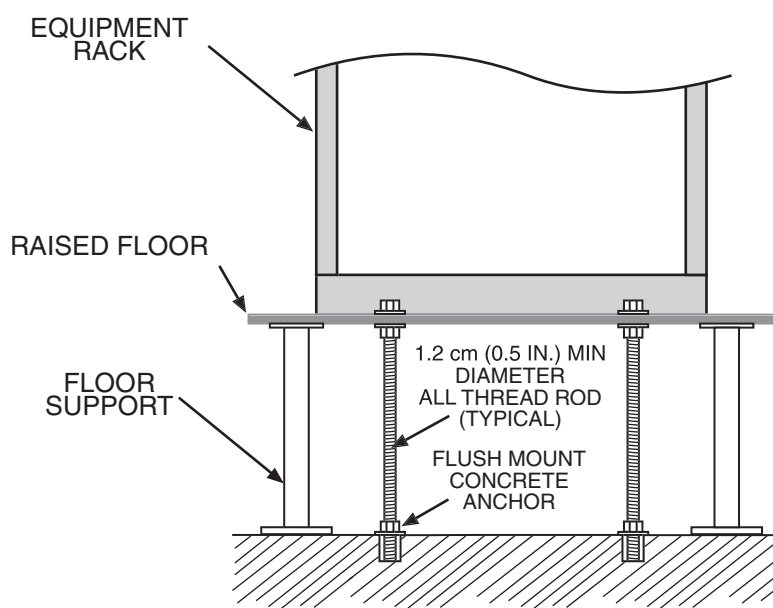

FIGURE 9-5 ANCHORING EQUIPMENT TO RAISED FLOORS

9.6.4 ANCHORING OVERHEAD AND WALL-MOUNTED EQUIPMENT

The anchoring of overhead and wall-mounted devices present a number of considerations. Placement is very important; if equipment is bolted to a wall that is on an aisle, the aisle may be unacceptably narrowed with the danger of injury to personnel. Also, the serviceability of the equipment being mounted to adjacent equipment may be inhibited.

Overhead applications generally include coax cabling, cable runways, and mounts for earthquake bracing. All overhead applications should keep in mind loading of overhead surfaces. Care must be exercised when deciding how much can be held up by the ceiling without some sort of building foundation support. In the case of earthquake bracing equipment (discussed in "Seismic Considerations" on page 9-3), cable trays can be secured overhead then affixed to the equipment racks providing acceptable foundation support.

When anchoring cable trays to ceilings or walls, the manufacturer-supplied support hardware **shall** be used.

Anchors used in overhead applications vary depending on the ceiling structure as follows:

- For concrete and wood ceilings, the same principles discussed in floor anchoring apply.
- For an exposed steel I-Beam ceiling, many cable runway manufacturers make beam clamps for C-channel or threaded drop rods.
- For corrugated steel ceilings, C-channel tracks can be affixed to the ceiling using properly sized lag bolts. The C-channel will span the corrugated steel and provide multiple anchor points.

For drywall or plasterboard ceilings, special considerations are required:

- If the drywall is on steel or wooden roof joists, locate and tap into the roof joists with lag bolts.
- C-channel mounting can be used.
- An alternative to C-channel mounting is using large toggle or molly wings with hex head tap bolts.

NOTE: Make certain joists are properly located before drilling into drywall. If any existing equipment is on site, ensure it is covered with an anti-static tarp or covering.

9.7 EQUIPMENT INSTALLATION WITHIN RACKS OR CABINETS

Most communication equipment is mounted into standard 19-in EIA racks or enclosed cabinets. Follow the rack and/or equipment manufacturer's instructions when installing equipment into racks or cabinets.

- All supplied bracing hardware **shall** be properly utilized.
- Proper hardware **shall** be used to secure equipment.
- See Chapter 5 for proper equipment grounding.
- Convected heat transfer from one piece of equipment rack to another **shall** be considered. Heat baffles or fan kits may be required.



WARNING

Do not mount heavy equipment at the top of the equipment rack or cabinet. It may cause the rack to become top-heavy and unstable.

9.8 ANCILLARY EQUIPMENT MOUNTING

Any permanent site equipment that is not rack- or cabinet-mounted, should be permanently secured or mounted, including items placed on rack- or cabinet-mounted peripheral trays.

9.9 EQUIPMENT CABLING

This section describes requirements for cabling within equipment cabinets and racks, and requirements for cable runs between equipment cabinets/racks. Cabling within racks and cabinets **shall** conform to the requirements of NFPA 70-2005, Article 300, Article 800, Article 810, Article 820, and Article 830. (See ANSI/TIA/EIA-568(b) and 569(b) and NECA/BICSI 568-2001 for additional information.)

9.9.1 CABLING REQUIREMENTS FOR EQUIPMENT IN RACKS AND CABINETS

All cables **shall** be installed and routed so that personal safety and equipment functionality is not compromised and that all equipment is accessible for servicing. The following requirements apply to cabling installed in racks or cabinets:

9.9.1.1 SECURING CABLES WITHIN RACKS OR CABINETS

- To help prevent damage or accidental disconnection, cables and conductors **shall** be secured at intervals of no more than 914 mm (3 ft.). Attachment **shall** be accomplished in a manner that does not restrict access to the equipment in the rack or cabinet.
- Insulated standoffs are recommended for use in racks or cabinets. The standoffs should be of sufficient length to maintain the proper cable separation.
- Nonmetallic cable ties **shall** be used to secure cables and conductors. Attachment **shall** be tight enough to secure cables without crushing or deforming them.
- Nonmetallic cable ties must be cut with flush cut sidecuts directly adjacent to the locking tab to prevent sharp protrusions.

9.9.1.2 ROUTING CABLES WITHIN RACKS AND CABINETS

- Grounding conductors within racks or cabinets **shall** be routed toward the RGB, MGB, SSGb, or ground bus conductor. Connections to the RGB or ground bus conductor **shall** always be made with the equipment grounding or tap conductors being routed toward the MGB, SSGb, or RGB. See Figure 5-17 on page 5-24 for an example.
- Whenever possible, cable groups of different types should maintain 50.8 mm (2 in.) separation when passing through the cabinet housing. When the 50.8 mm (2 in.) separation cannot be maintained at the through the cabinet housing penetration, separation **shall** be maintained before and after the penetration point. See Figure 5-14 on page 5-22 for an example.
- Cables in racks or cabinets **shall** be sized to length, and **shall** be installed and routed neatly and in a workmanlike manner.
- AC power cords longer than necessary may be looped down and back up a rack or cabinet. Excess lengths of AC power cord **shall not** be coiled on top of racks or cabinets.

9.9.1.3 PROTECTING CABLES WITHIN RACKS AND CABINETS

- Where cables or conductors are routed through holes in metallic surfaces or near sharp edges, the sharp surfaces **shall** be suitably protected with a grommet or similar material to help protect the cable or conductor from damage caused by sharp edges.
- Ensure cables are not crimped or bent when cabinet doors are opened or closed.

9.9.1.4 CABLE BENDING RADIUS WITHIN RACKS AND CABINETS

- Grounding conductors of all sizes **shall** maintain a minimum bending radius of 203 mm (8 in.). The angle of any bend **shall** be not less than 90 degrees.
- The bending radius of CAT-5 cables **shall** be not less than 10 times the outside diameter of the cable. Follow the cable manufacturer's recommendations and see ANSI/TIA/EIA-568(b) and CSA-T529-1995 for additional information.
- All other cables **shall not** have sharp bends which will damage or degrade the performance of the cable. The cable manufacturer's specifications **shall** be followed.

9.9.1.5 CABLE SEPARATION AND GROUPING WITHIN RACKS AND CABINETS

- Cabling in racks or cabinets **shall** be grouped according to function. Groups are defined as:
 - AC power cords
 - DC power cables
 - Ground conductors
 - RF transmission cabling
 - Data, control, signal and timing reference cabling and telephone cabling
- Cable groups within racks and cabinets **shall** be separated by 50.8 mm (2 in.) from other cable groups. See ANSI/TIA/EIA-568(b) and -569(b); and NFPA 70-2005, Articles 800.133, 810.18, 820.133 and 830.133 for additional information.
- When practical, cable groups at or in close proximity to equipment chassis should be separated by 50.8 mm (2 in.) or cross at a 90 degree angle.

9.9.2 COMMUNICATION CABLING REQUIREMENTS FOR PLENUMS AND OTHER AIR-HANDLING SPACES



WARNING

Non-plenum rated power cabling shall not be installed within plenums. Failure to use plenum-rated cables in these areas can result in generation of toxic fumes in the event of a fire.

NOTE: Feasibility and methods of wiring within plenums and risers **shall** conform with jurisdictional codes.

The following requirements specify installation practices that help, should a fire occur, minimize smoke and products of combustion from electrical wiring in areas that handle environmental air. A plenum is defined as a compartment or chamber to which one or more air ducts are connected and that forms part of the air distribution system. See NFPA 70-2005, Article 100 for additional information.

- Wiring systems of any type **shall not** be installed in ducts used to transport dust, loose stock, or flammable vapors (NFPA 70-2005, Article 300.22(A)).
- Wiring systems of any type **shall not** be installed in any duct, or shaft containing only such ducts, used for vapor removal (NFPA 70-2005, Article 300.22(A)).

- Wiring systems may be installed in ducts specifically constructed to transport environmental air only when such wiring consists exclusively of the following. See NFPA 70-2005, Article 300.22(B) for additional information:
 - Type MI (mineral insulated) cable
 - Type MC (metal-clad) cable employing a smooth or corrugated impervious metal sheath without an overall nonmetallic covering
 - Type CMP (communications plenum cable), electrical metallic tubing, flexible metal tubing, intermediate metal conduit, or rigid metal conduit. Flexible metal conduit and liquid-tight flexible metal conduit **shall** only be permitted in lengths not exceeding 1.22 m (4 ft.), to connect physically adjustable equipment and devices permitted to be in the ducts. See NFPA 70-2005, Article 300.22(B) for additional information.
- Wiring installed in other spaces used for environmental air, such as the area above a suspended ceiling or as otherwise defined in NFPA 70-2005, Article 300.22(C), **shall** be installed in accordance with NFPA 70-2005, Article 300.22(C). Such wiring methods include using Type MI (mineral insulated) cable, Type MC (metal-clad) cable without an overall nonmetallic covering, and Type AC (armored cable) cable. See NFPA 70-2005, Article 300.22(C) for additional information.

**WARNING**

Electrical installations installed in hollow spaces, vertical shafts, and ventilation or air-handling ducts shall be installed in a manner such that the possible spread of fire or products of combustion will not be substantially increased. Openings around penetrations through fire resistance-rated walls, partitions, floors, or ceilings shall be firestopped using approved methods to maintain the fire resistance rating. Firestopping such penetrations may be accomplished by using specially manufactured fire seals or fire-barrier caulking. See NFPA 70-2005, Article 300.21, ANSI/TIA/EIA-569(b), and NECA/BICSI 568-2001 for additional information.

- Communications cables installed in vertical runs spanning more than one floor, or cables installed in vertical runs in a shaft **shall** be Type CMR (Communications riser cable) or Type CMP (NFPA 70-2005, Article 800.154(B)).
- A bare grounding conductor may be installed in a plenum area. If a bare conductor is used, it **shall** be properly secured and protected from making incidental contact with other metallic objects not meant to be bonded to the grounding conductor. Plenum-rated insulated sleeving may be used to prevent incidental contact.
- See NFPA 70-2005, Article 645 for details on Information Technology equipment room wiring.

9.9.3 CABLING REQUIREMENTS FOR CABLE TRAYS OR LADDERS

9.9.3.1 CABLE INSTALLATION WITHIN CABLE TRAYS OR LADDERS

- Cables that span a horizontal gap greater than 610 mm (2 ft.) **shall** be supported.
- When installing cables into a cable tray system, cables **shall not** be pulled with such force that the conductor insulation or cable jacket integrity is destroyed or that the cable is deformed.
- Antenna and transmission lines minimum bending radii **shall** be considered when placing these cables within the cable tray. Follow manufacturers' specifications.
- Cables installed within a cable tray system **shall** be fastened securely to transverse members in all horizontal and vertical runs every 914 mm (36 in.).
- The most desirable method to exit the cable runway is to drop out the bottom into a rack/cabinet or a vertical support such that physical separation is maintained.
- AC power cables **shall not** be run within a cable runway system unless they are enclosed within metallic conduit or raceway.

NOTE: Raceways or conduit installed below or along side cable runways may not be supported by the cable runways themselves unless the cable runway system is designed to provide such support.

9.9.3.2 CABLE SEPARATION AND GROUPING WITHIN CABLE TRAYS

- Cable groups **shall** be separated a minimum of 50.8 mm (2 in.) from other cable groups. (See ANSI/TIA/EIA-568(b) and 569(b); NFPA 70-2005, Articles 800-133, 800-18, and 820-133 for additional information.)
- Transmission lines (coax) for transmitting stations **shall** be separated a minimum of 101 mm (4 in.) from electrical lights, power, and signaling circuits (NFPA 70-2005, Article 810.70).
- Groups are defined as:
 - AC power, DC Power, ground conductor and RF transmission cabling
 - Data, control, signal and timing reference cabling
 - Telephone cabling
- At a minimum the above group separation must be maintained. However with adequate cable tray space, logical sub-groups are permitted such as, bundles of DC cabling, bundles of RF cabling, etc.
- AC power cables cannot be run in the same cable tray as CAT-5 or communications cables unless separated by a barrier as defined by NFPA 70-2005. (See "Computer Network Cabling" on page 9-18 for additional information.)

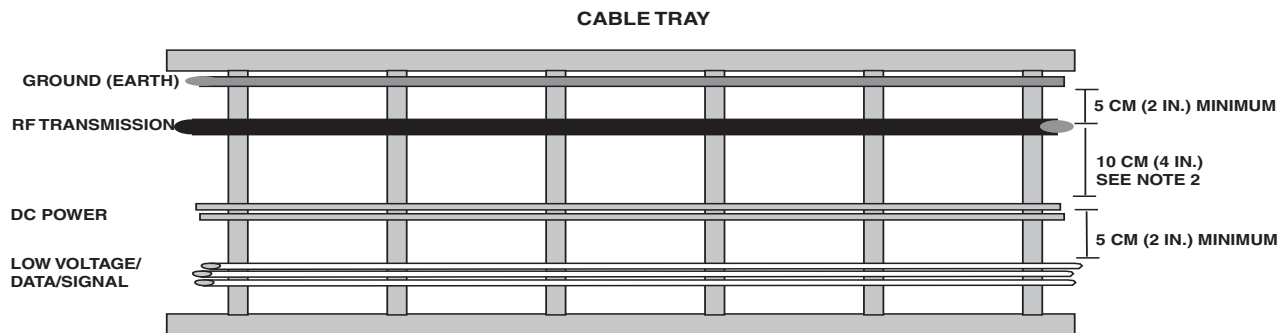
**NOTES:**

1. Each cable type may be single or multiple cables of the same type grouped together.
2. If the ground conductor is installed on the outside of the rack, coaxial RF transmitting cable shall be 10 cm (4 in.) away from any other cables (power and low voltage) as described in NFPA 70-2005, Article 810.70. Receiving coaxial RF cables require a 5 cm (2 in.) separation.

FIGURE 9-6 MINIMUM CABLE GROUP SEPARATION IN CABLE TRAY**9.9.3.3 SECURING CABLES WITHIN CABLE TRAYS**

- Cables and conductors **shall** be secured at intervals of no more than 914 mm (3 ft.).
- Nonmetallic cable ties **shall** be used to secure cables and conductors. Attachment **shall** be tight enough to secure cable, yet not crushing or deforming the cable.
- Cables running vertically on a cable ladder **shall** be secured at a minimum of 914 mm (36 in.). It is preferable to secure them at every rung, but not required.
- When cables span a gap (such as between a cable tray and a ladder) in excess of 610 mm (24 in.), the cables **shall** be supported.
- Certain telephony requirements may exist for cables to be laced. See “Cabling in Telephone Wiring Environments” on page 9-28 for additional information.
- Cable **shall** be sized to length including a sufficient service loop. Excess cable **shall not** be coiled on top of cabinets or cable trays.
- Communications cables **shall not** be attached by any means to the exterior of a conduit or other raceway as a means of support (NFPA 70-2005, Articles 725.58 and 800.133(C)).
- Communications cables **shall not** be laid directly on the tiles or grid work of a false ceiling (ANSI/TIA/EIA-569(b)), NFPA 70-2005, Article 725.7, 800.21, and 820.21).

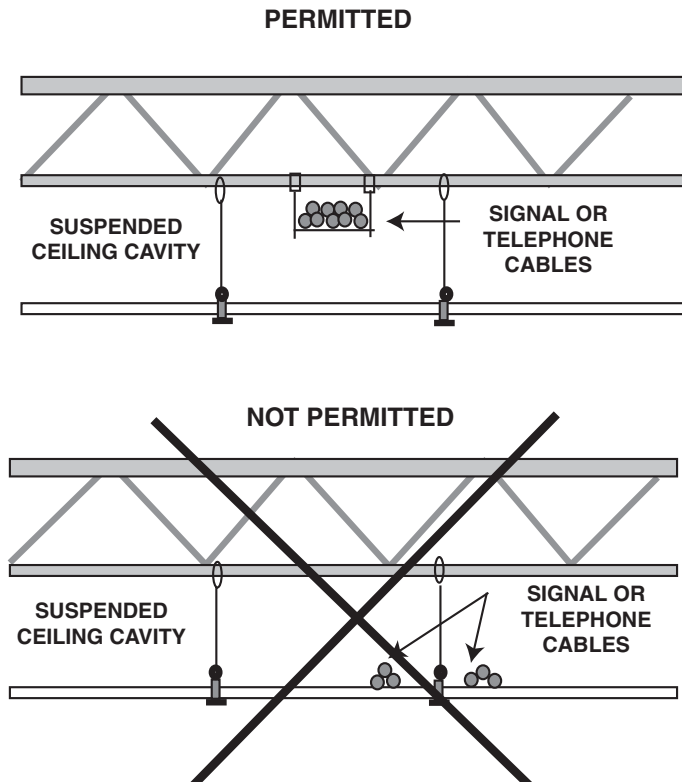

FIGURE 9-7 COMMUNICATIONS CABLES IN SUSPENDED CEILINGS

9.9.4 AC POWER CABLING



WARNING

Facility AC wiring within junction boxes, receptacles, and switches shall be performed by a licensed and bonded electrical contractor. Personnel safety and liability hazards can result from AC wiring performed by installation personnel other than an electrical contractor.

When an open equipment rack is used, hardwiring of power is not always possible. Mounting a dedicated simplex receptacle or receptacle assembly on the rack may be the most convenient method of supplying power, especially if multiple pieces of equipment are mounted on the rack.

These receptacle assemblies can be pre-manufactured and mounted to the top face of an equipment rack. Mounting can also use a fabricated power pole mounted between racks.



WARNING

Under no circumstances shall consumer-grade power outlet strips be used in any installation. Extension cords of any type shall not be used for connecting line power to communications equipment.

9.9.5 DC POWER CABLING

In telecommunications environments, common DC systems are as follows:

- +12 volt systems
- +24 volt systems
- -24 volt systems
- -48 volt systems

Traditional wireline telephone offices most often use -48V, sometimes called -BATT voltage, whereas many cellular, PCS, and other radio systems use +24 to 27 V. There are also instances of -24V systems. In U. S. installations, the most common practice is to use red cabling for the sourcing, fused, ungrounded, “hot” terminal. Black cabling is used for the return, unfused, grounded, terminal. (European installation practice uses blue insulation for the “hot” lead.) Chapter 8, “Power Sources,” discusses power cabling sizing and other installation concerns. The manual for the equipment being installed will also have specifications stating the cabling size required. Careful consideration must be given to cable size and length. See Chapter 6, “Power Sources” and cabling capacity for further information.

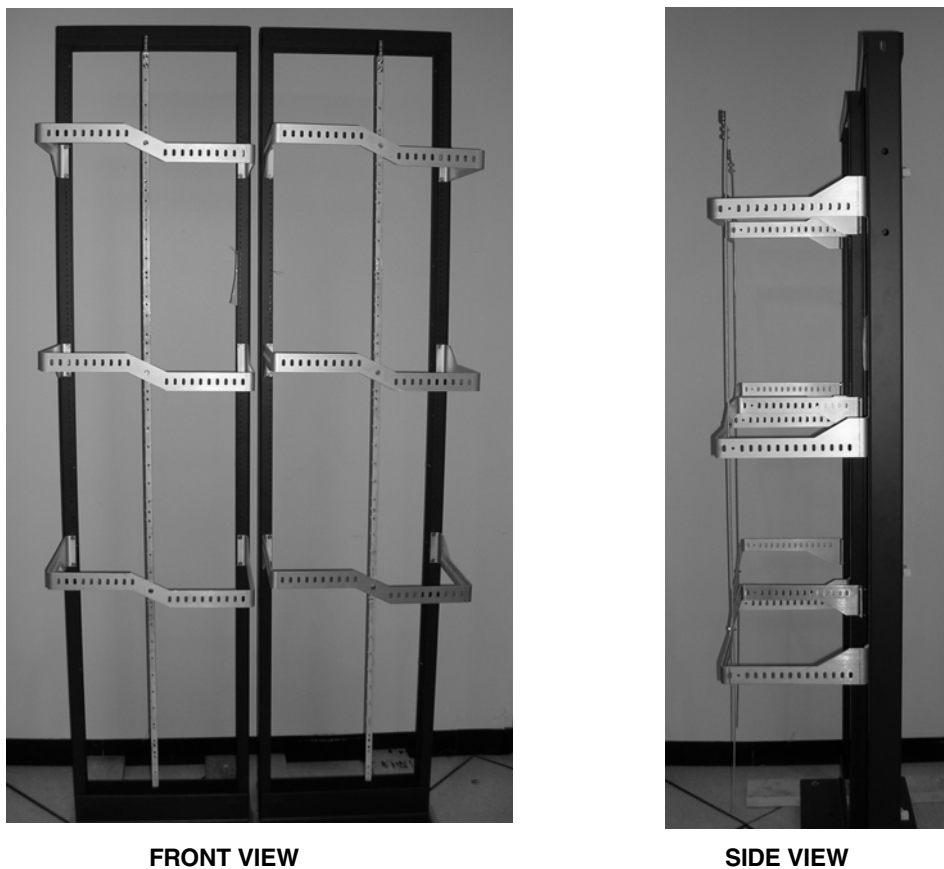

FIGURE 9-8 CABLE MANAGEMENT SYSTEM WITH INTEGRATED RACK GROUND BUS BAR

9.9.6 COMPUTER NETWORK CABLING

Computer network cabling typically consists of Category 5 (CAT 5) cabling terminated with 8-pin modular connectors.

The proper installation of computer network cabling is critical to the safe and reliable operation of the computer network. It is recommended that standards developed by the Telecommunications Industry Association/Electronic Industries Association (TIA/EIA) and the Canadian equivalent (or equivalent standards in other countries) be followed. Applicable NFPA codes, local electrical codes, local building codes and other standards in this manual **shall** also be conformed to when installing computer network cabling.

NOTE: It is recommended that computer network cable installations be performed by a specialist in the installation of computer networks. The specialist should have the expertise, knowledge of applicable local codes, and the test equipment required for a quality installation.

NOTE: This section cites standards from the American National Standards Institute (ANSI), the Electronic Industry Association (EIA), the Telecommunications Industry Association/Electronic Industries Association (TIA/EIA), and the Canadian Standards Association (CSA). These standards should be followed even for sites located outside the U.S.

9.9.6.1 CABLE TYPE

CAT 5 Unshielded Twisted Pair (UTP), 100-ohm cable is the recommended cable type for computer network cabling, and will be the assumed cable type throughout this section. CAT 5 cable is preferred over CAT 3 and CAT 4 cables because of its ability to support 100Mbps (Megabits per second) systems and because of its improved immunity to Electromagnetic Interference (EMI) and Radio Frequency Interference (RFI). See American National Standards Institute/ Telecommunications Industry Association/ Electronic Industries Association ANSI/TIA/EIA-568-B and Canadian Standards Association CSA-T529 for additional information.

9.9.6.2 CONNECTING HARDWARE

UTP cables **shall** be terminated with connecting hardware of the same category rating or higher. This includes all connectors, punch blocks, cross-connect jumpers and patch cords. It is recommended that hardware used to terminate cables be of the insulation displacement (IDC) type. Modular connectors **shall** also be of the proper type for the cable used; solid conductor cable uses a different connector than stranded cable. See ANSI/TIA/EIA-568-B and CSA-T529 for additional information.

9.9.6.3 CABLE AND CONNECTOR WIRING

Appropriate color-coding and jack pair assignments should be followed when wiring modular jacks, connectors, and cables. The same wiring standard **shall** be used throughout the cabling system. ANSI/TIA/EIA T568A and T568B are the recommended standards. Figure 9-9 shows the color coding and Figure 9-10 shows end views of an 8-pin modular female jack for both standards with the pairs and colors identified. See ANSI/TIA/EIA-568-B and CSA-T529 for additional information.

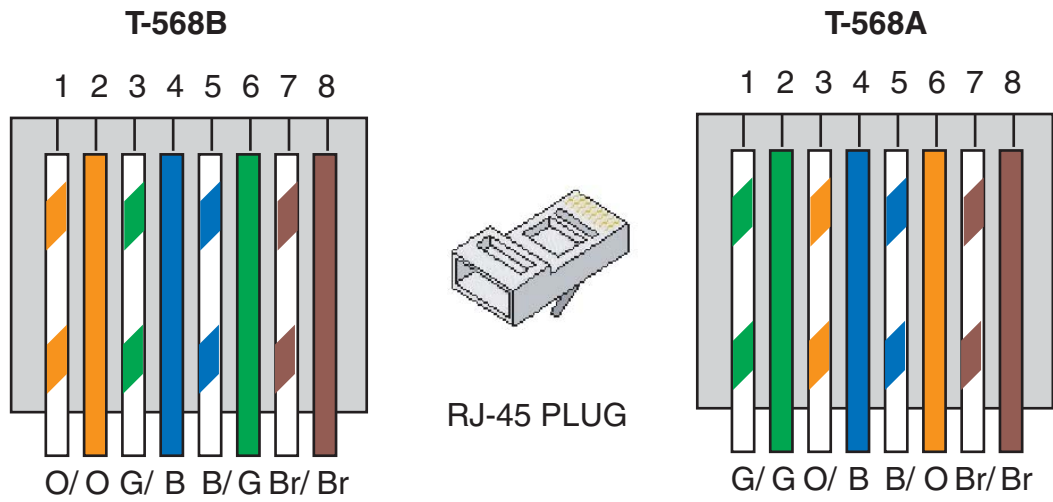
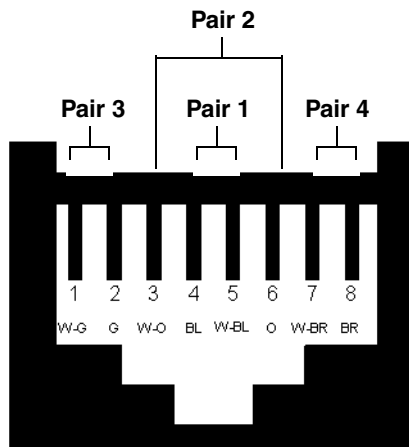
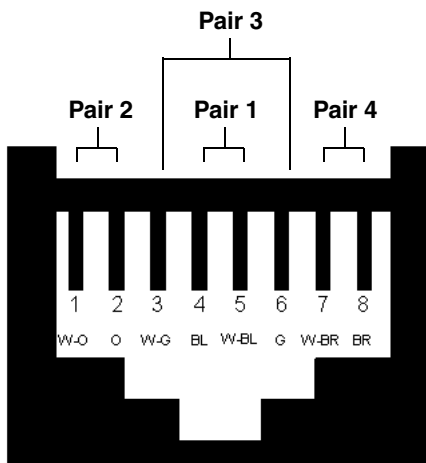

FIGURE 9-9 RJ-45 COLOR CODING



Cable Pair	Color
1 (term 4, 5)	white-blue (W-BL) blue (B)
2 (term 3, 6)	white-orange (W-O) orange (O)
3 (term 1, 2)	white-green (W-G) green (G)
4 (term 7, 8)	white-brown (W-B) brown (BR)

T568A Connections



Cable Pair	Color
1 (term 4, 5)	white-blue (W-BL) blue (B)
2 (term 1, 2)	white-orange (W-O) orange (O)
3 (term 3, 6)	white-green (W-G) green (G)
4 (term 7, 8)	white-brown (W-B) brown (BR)

T568B Connections

NOTE: For both connectors, female jack is shown (view from FRONT (mating) end of connector shown)

FIGURE 9-10 8-PIN MODULAR JACK PINOUT

9.9.6.4 CABLE INSTALLATION AND ROUTING

Observe the following additional considerations for network cabling in addition to the general requirements throughout the rest of this manual:

- Consideration should be given to using some method of cable management and containment for runs of CAT 5 cable. Such methods can be dedicated cable runs, lay-in wireways, cable trays and conduits. See ANSI/TIA/EIA-569-B and CSA-T530 for additional information.
- CAT 5 cable **shall not** be installed in the same conduit, cable tray, outlet box, or similar device with AC power cables, unless separated by a barrier as allowed in NFPA 70-2005, Article 800.52. Doing so can be unsafe and is likely to cause EMI onto the CAT 5 cable, causing network errors. See NFPA 70-2005, Article 800.133, ANSI/TIA/EIA-568-B, 569-B, and CSA-T529, T530 for additional information.
- Avoid routing CAT 5 cable near sources of EMI/RFI. Such noise sources may be electrical power wiring, dimmer switches, radio frequency transmitters, motors, generators, and fluorescent lights. Precautions include increasing the physical distance between the CAT 5 cable and the source of the EMI/RFI; installing the cable inside a grounded metallic conduit; or use of a CAT 5 100-ohm screened twisted pair cable as permitted by ANSI/TIA/EIA-568-B. Routing cables near sources of EMI/RFI can cause data errors and degraded system performance. See ANSI/TIA/EIA-568-B, 569-B and CSA-T529, T530 for additional information.
- Cables **shall** be separated by at least 50.8 mm (2 in.) from AC power conductors. See NFPA 70-2005, Article 800.133 for additional information.
- CAT 5 cables installed in ducts, plenums, and other air-handling spaces **shall** be installed in accordance with other chapters of this manual and NFPA 70-2005, Article 300.22. See also NFPA 70-2005, Article 645.
- CAT 5 cables installed in hazardous areas as defined in NFPA 70-2005, Article 500 **shall** be installed in accordance with NFPA 70-2005, Article 500 and any other applicable electrical and building codes.
- CAT 5 cable **shall not** be attached by any means to the exterior of a conduit or other raceway as a means of support. See NFPA 70-2005, Article 725.58 and NFPA 70-2005, Article 800.133 for additional information.
- Suspended ceiling support rods and wires may be used as a means of support for computer network cabling if used in conjunction with appropriate cable fasteners. See ANSI/TIA/EIA-569-B and CSA-T530 for additional information.
- CAT 5 cables **shall not** be laid directly on the tiles of a false ceiling. See Figure 9-7. (ANSI/TIA/EIA-569(b)), NFPA 70-2005, Article 725.7, 800.21, and 820.21).
- CAT 5 cables **shall not** be run from one building to another building. If the computer network must be extended to another building, a specific cabling system **shall** be engineered. Options for extending from one building to another may include the use of fiber optic cable or a T-1. Computer network cabling entering and/or leaving a building **shall** be properly grounded and protected from surges as required elsewhere in this manual.

9.9.6.5 INSTALLATION PRACTICES

- Avoid unnecessary junction points and cross-connects. Every added junction point and cross-connect can decrease the performance of the network.
- Multiple appearances of the same cable at different locations, referred to as bridge taps, **shall** be avoided (see Figure 9-11). Each cable segment **shall** have only one source and one destination.

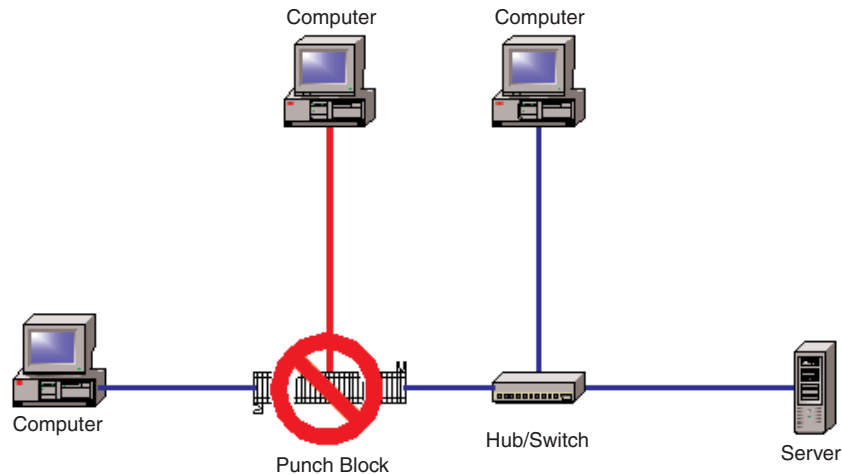

FIGURE 9-11 DISALLOWED “BRIDGE TAP” CONNECTION

- Never untwist the twisted pairs of a CAT 5 cable beyond 12.7 mm (0.5 in.) from the point of termination. Untwisting the wires can decrease the cable’s category performance rating and degrade system performance. See ANSI/TIA/EIA-568-B and CSA-T529 for additional information.
- Do not make sharp bends in CAT 5 cable. The bend radius for CAT 5 cable **shall not** be less than ten times the outside diameter of the cable. Bending the cable with a shorter bend radius can affect the electrical characteristics of the cable and degrade system performance. See ANSI/TIA/EIA-568-B and CSA-T529 for additional information.
- Do not pull a CAT 5 cable using a force greater than 110 Newtons (25 lb-force), or as suggested by the cable manufacturer. Pulling a cable with too much force can change the cable’s electrical characteristics and degrade its performance. See ANSI/TIA/EIA-568-B and CSA-T529 for additional information.
- Do not over-tighten CAT 5 cable with cable ties or other supports. Over-tightening cable ties or other supports can change the electrical characteristics of the cable and degrade the system performance. Velcro-style cable ties are recommended. See ANSI/TIA/EIA-568-B and CSA-T529 for additional information.

9.9.6.6 TOPOLOGY

Computer network cabling **shall** utilize a “Star” topology, unless the specific design of the network calls for a different topology. Figure 9-12 shows a star topology example. See ANSI/TIA/EIA-568-B and CSA-T529 for additional information.

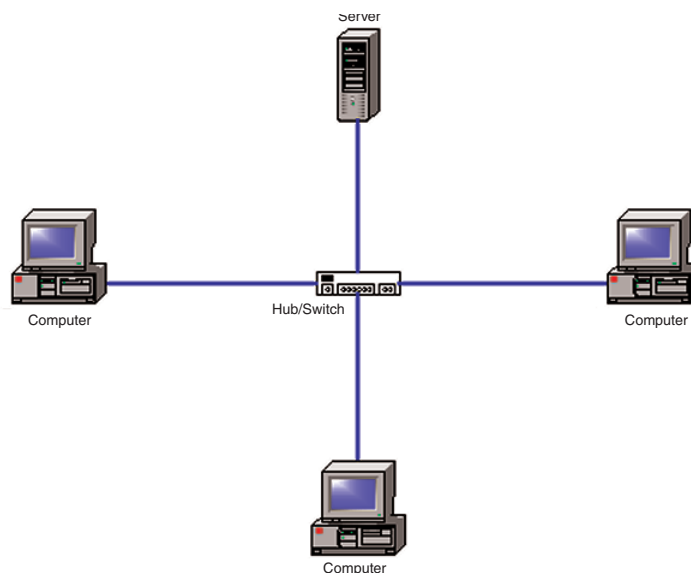

FIGURE 9-12 STAR TOPOLOGY

- CAT 5 segment lengths **shall not** exceed 100 m (328 ft.). This includes 90 m (295 ft.) of building cabling and up to 10 m (32.8 ft.) of equipment cords, cross-connects and patch cords. Of the 10 m (32.8 ft.) allowed for equipment cords, cross-connects and patch cords, a maximum of 3 m (9.8 ft.) should be used from the computer workstation to the information outlet. See ANSI/TIA/EIA-568-B and CSA-T529 for more details. Figure 9-13 shows the maximum cabling lengths between various network elements.

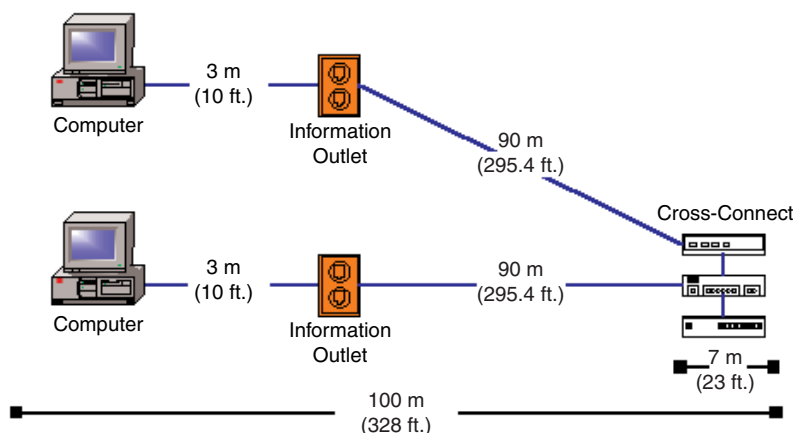

FIGURE 9-13 NETWORK SEGMENT LENGTHS LIMITATIONS

- For simplifying installation and reducing cable runs, a single CAT 5 cable may be run from the equipment room hub/switch to an additional hub/switch in the computer workstation area for distribution to the individual computers. This can reduce the number of cables required between the equipment room and the individual computers. Figure 9-14 shows an example of a single cable run. See ANSI/TIA/EIA- 569-B for additional information.

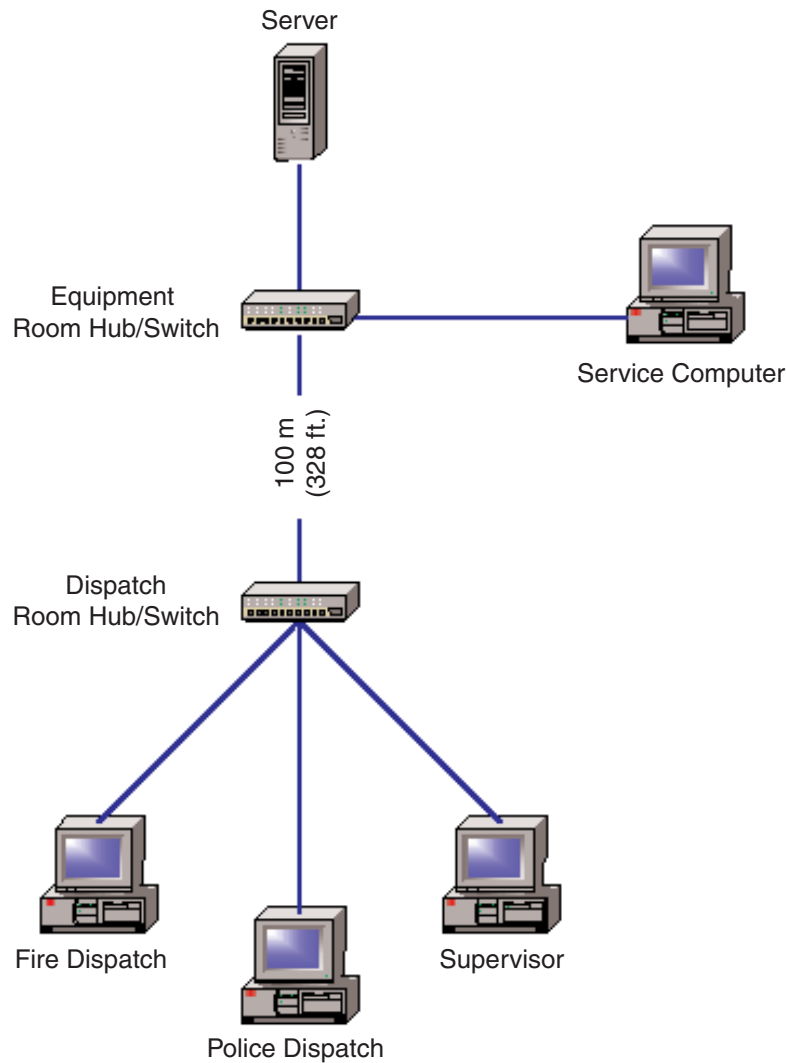

FIGURE 9-14 ADDITIONAL HUB/SWITCH USED IN SINGLE CABLE RUN

- If cable segments need to be extended beyond 100 m (328 ft.), an additional hub/switch may be installed. Each individual segment between hubs/switches **shall** not exceed 100 m (328 ft.). Figure 9-15 shows the cabling and network elements for distances exceeding 100 m (328 ft.). Note that no more than the one intermediate hub/switch **shall** be used. If the required distance is greater than as shown in Figure 9-15 on page 9-25, a specific cabling system **shall** be engineered. See ANSI/TIA/EIA- 569-B for additional information.

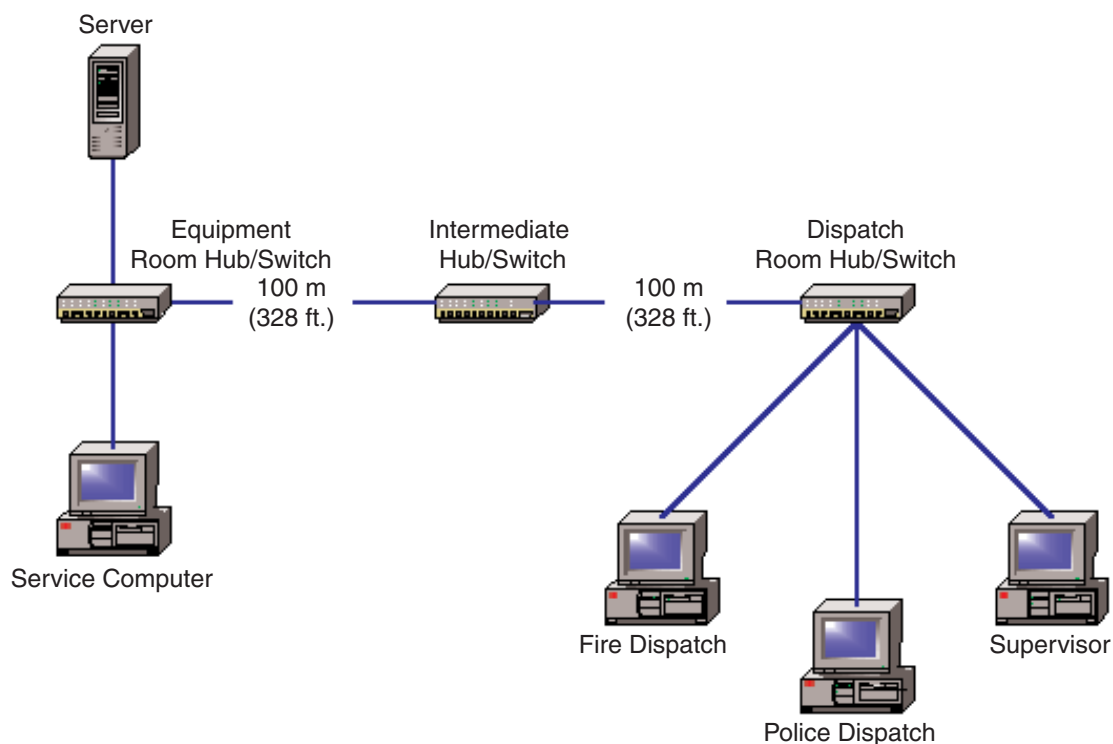

FIGURE 9-15 ADDITIONAL HUB/SWITCH USED FOR DISTANCES GREATER THAN 100 M

9.9.6.7 GROUNDING

Grounding **shall** comply with Chapter 5, “Internal Grounding (Earthing),” of this manual, NFPA 70-2005, Article 250; ANSI-J-STD-607-A-2002, and CSA-T527.

9.9.6.8 LABELING

Cables **shall** be labeled at both ends and at any pull boxes or junctions as described in “Cable Labeling” on page 9-30. See also ANSI/TIA/EIA-606-A and CSA-T528 for detailed labeling guidelines and suggestions.

9.9.6.9 TESTING NETWORK CABLING

Every effort should be made to ensure a quality installation of the computer network cabling system. Even the best installation effort cannot guarantee a properly working system. It is therefore required that a computer network cabling system be tested for proper performance.

The procedures and specifications in the TIA/EIA Telecommunications System Bulletin (TSB) 67 **shall** be used for this testing. TSB 67 has four primary parameters to test. Below is an overview of the four test parameters needed to assure a properly working system.

9.9.6.9.1 WIRE MAP

The wire map test is used to verify wire pair to pin termination at each end of the cable and check for installation connectivity errors. Each of the 8 conductors in the cable are tested for:

- Conductor continuity to the remote end of the cable
- Shorts between any two or more conductors in the cable
- Crossed pairs in the cable
- Reversed pairs in the cable
- Split pairs in the cable
- Any other wiring errors in the cable

9.9.6.9.2 LENGTH

The length test is used to determine the maximum physical length of the cable segments.

9.9.6.9.3 ATTENUATION

Attenuation is the measure of signal loss in the cable segment.

9.9.6.9.4 NEAR-END-CROSSTALK (NEXT) LOSS

NEXT loss is a measure of signal coupling from one wire pair to another within a single UTP cable segment.

9.9.7 OPTICAL FIBER CABLING



WARNING

Never look into an optical fiber cable. Optical fiber cables use invisible laser light that is dangerous and can cause damage to the eye.

Optical fiber cable are grouped into three general categories as described below. (See NFPA 70-2005, Article 770.9 for additional information.)

- Non-conductive - These cables contain no conductive materials.
- Conductive - These cables contain noncurrent-carrying conductive members, such as metallic strength members, metallic vapor barriers, and metallic armor or sheath.
- Composite - These cables contain optical fibers and current-carrying electrical conductors. These cable may also contain noncurrent-carrying conductive members, such as metallic strength members and metallic vapor barriers.

Observe the following general considerations for the installation of optical fiber cabling:

- Optical fiber cable installations **shall** conform to ANSI/TIA/EIA-568-B.
- Bend radius **shall not** be shorter than 10 times the diameter of the optical fiber cable, or as recommended by the cable manufacturer.

- Optical fiber cables **shall not** be installed in such a way that it prevents access to electrical equipment and removal of panels, including suspended ceiling panels. (See NFPA 70-2005, Article 770.21, and Figure 9-7 for additional information.)
- Optical fiber **shall** be installed in a neat and workmanlike manner. Cables **shall** be supported in such a manner that the optical fiber cable will not be damaged by normal use of the building. (See NFPA 70-2005, Article 770.24 for additional information.)
- Conductive optical fiber cables entering or leaving the building **shall** be have the noncurrent-carrying metallic members grounded as close as practical to the building entry. (See NFPA 70-2005, Article 770.93 and Chapter 5, “Internal Grounding (Earthing),” for additional information.)
- Optical fiber cables installed in plenums and other air-handling spaces **shall** be Plenum-rated cable and installed in accordance with NFPA 70-2005, Article 770. Plenum-rated optical fiber cable may be OFNP (Optical Fiber Non-conductive Plenum) or OFCP (Optical Fiber Conductive Plenum).
- Optical fiber cables installed in vertical runs penetrating more than one floor, or cables installed in vertical runs in a shaft **shall** be Riser or Plenum-rated cable. Riser rated optical fiber cable may be OFNR (Optical Fiber Non-conductive Riser) or OFCR (Optical Fiber Conductive Riser). (See NFPA 70-2005, Article 770 for additional information.)
- Non-conductive optical fiber cable **shall** be permitted to occupy the same cable runway or raceway with conductors for electric light, power, Class 1, nonpower-limited fire alarm, or medium power network-powered broadband communications circuits operating at 600 Volts or less. (See NFPA 70-2005, Article 770.133 for additional information.)
- Conductive optical fiber cable **shall not** be permitted to occupy the same cable runway or raceway with conductors for electric light, power, Class 1, nonpower-limited fire alarm, or medium power network-powered broadband communications circuits. (See NFPA 70-2005, Article 770.133 for additional information.)
- Composite optical fiber cables containing only current-carrying conductors for electric light, power, Class 1 circuits rated 600 Volts or less **shall** be permitted to occupy the same cabinet, cable runway, outlet box, panel, raceway, or other termination enclosure with conductors for electric light, power, or Class 1 circuits operating at 600 Volts or less. (See NFPA 70-2005, Article 770.133 for additional information.)
- Non-conductive optical fiber cables **shall not** occupy the same cabinet, outlet box, panel, or similar enclosure housing the electrical terminations of an electric light, power, Class 1, nonpower-limited fire alarm, or medium power network-powered broadband communications circuit, unless the optical fiber cable is functionally associated with the other cables. (See NFPA 70-2005, Article 770.133 for additional information.)
- Where exposed to contact with electric light or power conductors, the non-current-carrying metallic members of optical fiber cables entering buildings **shall** be grounded as close to the point of entrance as practical or **shall** be interrupted as close to the point of entrance as practical by an insulating joint or equivalent device (NFPA 70-2005, Article 770.93).
- Conductive and non-conductive optical fiber cable **shall** be permitted in the same cable runway, enclosure, or raceway with conductors of Class 2 and Class 3 remote-control, signaling, and power-limited. circuits in compliance with NFPA 70-2005, Article 725; power-limited fire alarm systems in compliance with NFPA 70-2005, Article 760; communications circuits in compliance with NFPA 70-2005, Article 800; community antenna television and radio distribution systems in compliance with NFPA 70-2005, Article 820; and low-power network-powered broadband communications circuits in compliance with NFPA 70-2005, Article 830. (NFPA 70-2005, Article 770.133).
- Where fiber optic cabling is used, the fiber optic cable **shall** be labeled to distinguish it from electrical signal cabling. (See Figure 9-16.)



COLORED ARMOR



LABEL

FIGURE 9-16 FIBER OPTIC CABLE IDENTIFICATION

9.9.8 RF CABLING

RF cabling typically consists of 6.35 mm (0.25 in.) or 12.5 mm (0.5 in.) coaxial cables of foam filled or superflexible construction.

RF cabling **shall not** be run nearer than 50.8 mm (2 in.) to conductors of other wiring systems (NFPA 70-2005, Articles 810.18, 810.70, and 820.133). Bend radius considerations **shall** be observed as specified below, or as otherwise specified by the cable manufacturer.

Minimum bend radius for superflexible cable sizes:

- 6.35 mm (0.25 in.) diameter cable: 25.5 mm (1 in.) bend radius
- 12.5 mm (0.5 in.) diameter cable: 31.7 mm (1.25 in.) bend radius

Minimum bend radius for foam-filled cable sizes:

- 12.5 mm (0.5 in.) diameter cable: 127 mm (5 in.) bend radius
- 22.2 mm (0.875 in.) diameter cable: 254 mm (10 in.) bend radius
- 31.7 mm (1.25 in.) diameter cable: 381 mm (15 in.) bend radius
- 41.3 mm (1.625 in.) diameter cable: 508 mm (20 in.) bend radius

9.9.9 CABLING IN TELEPHONE WIRING ENVIRONMENTS

NOTE: The following considerations apply only in cases where customer work must meet specifications stipulated by a telephone utility. If no special stipulations are stated by the telephone company, best commercial practices such as Telcordia specifications may be used for telephone company cabling within the communication site. When installing cabling that connects with telephone company assets or a demarcation point, inquire about any lacing requirements before work is performed.

9.9.9.1 ELECTRICAL INTERFACE REQUIREMENTS

Connection to telephone company assets may require the use of surge suppression for customer signal circuits that interface to telephone company circuits. Inquire through the telephone company regarding these requirements before connecting to telephone company circuits.

9.9.9.2 CABLING LACING REQUIREMENTS

When installing a system for telephone company or possibly other utility companies, special cabling methods **may** be required. Observe the following considerations for the installation of telephone company cabling:

- Lacing, rather than nylon cable ties, **shall** be used as the preferred means of cable attachment to cable tray, to eliminate the possibility of sharp edges found on cut cable ties.
- The lacing method specified by the telephone company **shall** be used. Typical lacing is shown in Figure 9-17.



FIGURE 9-17 TELEPHONE COMPANY LACING METHODS

- Lacing is typically 4- or 9-ply waxed polyester twine.
- Lacing of horizontal cables in cable trays should be performed every 914 mm (3 ft.).
- Lacing of vertical cables to a cable ladder should be performed at every rung of the cable ladder. Any cable hanging between horizontal/vertical runways and racks cannot be unsupported for more than 610 mm (24 in.).

9.9.10 DISTRIBUTION FRAME CONFIGURATIONS

A distribution frame (Figure 9-18 on page 9-30) provides a centralized cross-connection point for audio, data, and alarm and control wiring between different pieces of equipment at a site and between the site and external lines. Distribution frames **shall** be implemented using one of the following methods:

- Distribution punch blocks affixed to a plywood panel that is mounted on a wall or a rack.
- Distribution punch blocks mounted on open-rack frames available from various manufacturers. These frames can be anchored to the floor; they save wall space at the cost of floor space.
- Typically, a distributed (as opposed to centralized) method is used. Pre-wired cross-connect panels (each 1 rack unit in height) distribute connections on a rack-by-rack basis. Typically, remote sites require one panel and the prime site is equipped with one to three panels, depending on the application.

- Cables should be dressed up into the cable runway or down into the under-floor raceway as dictated by the site design.

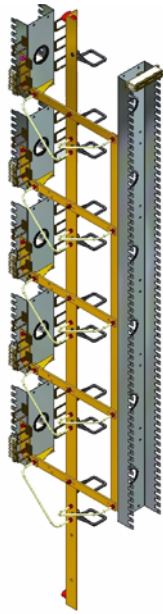

FIGURE 9-18 TYPICAL DISTRIBUTION FRAME

9.9.11 DISTRIBUTION FRAME CROSS-CONNECT WIRING

- Cross-connect wires **shall** be AWG #22 - #24 (0.644 mm - 0.511 mm) plastic-insulated **solid** copper wire. Stranded wire **shall not** be used.
- Individual wires **shall** enter the punch terminal from the top so that the wire tail points down after punch-down. (CAT3, 4, 5, or 6 data wiring **shall** enter punch terminals from the middle such that one wire points up while the other points down. In this manner, the cable twist that maintains the cable impedance stays intact.)
- The wiring **shall** dress down the source block column, across the bottom of the frame, and up the destination block column. Approximately 50.8 mm (2 in.) of service loop at each end of the punched down wire **shall** be allowed.
- Wiring **shall** be properly secured using industry-standard methods.

9.9.12 CABLE LABELING

Cabling **shall** be identified with a standardized, double-ended system to facilitate cable and equipment connection identification. (See ANSI/TIA/EIA-606 for additional information.) Observe the following when devising a cable labeling system:

- Labeling **shall** identify the direction along the cable where terminating equipment is located.
- Labeling **shall** indicate the destination ends of the cable, including equipment name and connector reference designator or name. This applies to connectorized, lugged, or punched down cable terminations regardless of the application (RF, audio, or control).

- Labeling **shall** be imprinted on white opaque material (preferably plastic or plasticized paper) using indelible black ink.
- Label placement **shall** be between 101 to 152 mm (4 to 6 in.) from each end of the cable (or the most logical point that would allow the label to be easily read).
- Labeling should wrap entirely around the cable. It should be secure enough to assure label retention if cable is to be pulled through conduit.
- Information printed on each label should be brief but clearly understandable. Use industry-standard abbreviations and acronyms to conserve label space.



FIGURE 9-19 EXAMPLE OF CABLE LABELING

9.10 ELECTROSTATIC DISCHARGE CONSIDERATIONS

Installation and repair of certain equipment will require removal and replacement of Field Replaceable Units (FRUs) within the equipment for purposes of setting configurations or installing FRUs specific to site applications. Whenever equipment must be opened, electrostatic discharge (ESD) precautions **shall** be adhered to. In general, the following requirements **shall** be met:

- An ESD-protected work area **shall** be present.
- An ESD wriststrap **shall** be worn when handling ESD-sensitive modules.
- ESD-protected packaging **shall** be available for containing modules removed from equipment.

All precautions specifically stated for the equipment being worked on **shall** be adhered to in accordance with the respective documentation for the equipment.

It is recommended that replacement FRUs be stored in their anti-static packaging, in an anti-static cabinet or enclosure to ensure that they are protected from ESD until they are needed for equipment repair.

See Appendix B for general ESD information.

THIS PAGE INTENTIONALLY LEFT BLANK.

ELECTROMAGNETIC ENERGY INFORMATION

This appendix discusses the following topics:

- “Environmental Evaluation,” on page A-2
- “Engineering Considerations,” on page A-14
- “Work Practices,” on page A-20
- “Signage,” on page A-24
- “Personal Protective Equipment (PPE),” on page A-26
- “EME Action Thresholds Summary,” on page A-27

NOTE: This appendix specifically references the United States FCC, but there are similar authorities having jurisdiction located around the world. Ensure that requirements of the relevant authorities having jurisdiction are implemented in your region.

A.1 INTRODUCTION

This appendix provides information to assist in understanding the concepts required to comply with FCC guidelines for human exposure to Electromagnetic Energy at antenna sites. This information is **not** intended to replace a structured training program, but is intended to provide basic information and methodology in structuring an Electromagnetic Energy compliance program. The methods presented in this appendix represent one approach for meeting FCC requirement; other methods may also meet FCC guidelines.

In August 1996, the Federal Communication Commission (FCC) adopted new guidelines for evaluating the environmental effects of Radio Frequency (RF) energy from transmitters on wireless communication sites. While there is no scientific evidence that RF emissions from these sites operating within established safety guidelines pose a health risk, fields close to antennas on transmitter sites must be understood and care must be taken to assure safe operation during maintenance. The guidelines adopted by the FCC provide considerable margins of protection from any known health risk.

This text discusses some of the issues involved in analyzing and understanding the Electromagnetic Energy (EME) environment that may exist on a complex communications site. A complex site is not only a site with hundreds of transmitters, antennas, and some broadcast, but any site with more than one RF transmitter. Considerable investigation has been done to understand the levels of exposure associated with such facilities, but little has been written on the implementation of procedures to ensure operating conditions in compliance with the FCC guidelines.

Modern communication sites typically contain many transmitters serving various functions or services, such as cellular, PCS, ESMR, paging, basic two-way radio, broadcast, etc. With each of these services requiring separate transmitters, in the past each service would typically develop its own sites and exist alone. However, with the dramatic growth of these services has come a growing incentive and need for transmitter collocation (the grouping of transmitters for different communications services at a single site). This collocation naturally results in correspondingly greater densities of EME fields about the site.

The drive for collocation comes from the need for more sites to satisfy public demand for more communications services, as well as public reaction to the proliferation and location of those sites. This will create communications sites more dense than has ever been dealt with before. In order to accommodate this natural growth in antenna density, more locations that consolidate communication transmitters are likely.

While collocation is a logical response to the marketplace factors outlined above, it presents challenges to the companies providing these services. As more transmitters are added to a site, the density of RF generators and EME increases. This is not unlike the situation found on a hilltop surrounding a large metropolitan area. The best hilltops have a high density of broadcast and communications sites. Because these are usually located on a common ridge or peak, the RF density may at times approach recognized exposure limits.

This appendix discusses some of the issues that must be considered in the management of a complex communications site. These considerations are important in order to ensure the operation of sites within recognized exposure limits. The RF density increases with the increase in the number of transmitters. However, operating conditions in compliance with the FCC guidelines can help be assured by the use of basic principles discussed here.

A.2 ENVIRONMENTAL EVALUATION

The possible health effects associated with exposure to EME have been studied for more than half a century. Scientists first identified the exposure threshold above which RF energy may cause adverse biological effects. The only established adverse effect of RF energy relates to the heating of tissue. Standard-setting bodies then set recommended exposure limits that are substantially below this threshold by at least a factor of 10 or more. With this substantial built-in margin of protection, these standards constitute reliable science-based guidelines for safe human exposure. Internationally, EME exposure standards exist in many countries. In the United States, one accepted standard comes from the American National Standards Institute C95 committee formed in the late 1950's. This committee has undergone many changes and implemented several standards. In 1988 the Institute of Electrical and Electronics Engineers (IEEE) became the sole sponsor of the C95 Committee, and the committee became the IEEE Standards Coordinating Committee (SCC), SCC28. In 1991 IEEE adopted their current standards as IEEE C95-1991. These standards were subsequently recognized by ANSI (American National Standards Institute) in 1992 as the ANSI/IEEE C95-1992 standard for safety levels of radio frequency exposure. The exposure limits in the ANSI standard are similar in many respects to those set by the National Council on Radiation Protection and Measurements (NCRP), an independent organization chartered by the U.S. Congress.

The Federal Communication Commission recently adopted guidelines which generally followed the recommendations of expert health and safety agencies such as the EPA, FDA, OSHA, NIOSH, and others, to adopt field and power density limits as recommended by the NCRP Report No. 86 and the SAR limits from the ANSI/IEEE C95.1-1992. (See FCC Report and Order (FCC 96-326) and Second Memorandum and Order (FCC 97-303) for additional information. These can be found on the FCC Office of Engineering and Technology website: www.fcc.gov/oet/rfsafety.)

A.2.1 EXPOSURE STANDARDS AND LIMITS

With the publication of the SCC28 standard as ANSI/IEEE C95.1-1992, a number of new elements were added to prior ANSI standards. These changes included modification of the exposure limits and the classification of exposure environments as Occupational/Controlled and General Population/Uncontrolled. Exposure limits in the new guidelines adopted by the FCC are specified in terms of Maximum Permissible Exposure (MPE) as a function of frequency; MPEs are given in units of electric and magnetic field strength and power densities. For exposure to multiple frequencies, the fraction (or percentage) of the MPE produced by each frequency is determined and these fractions (or percentages) must not exceed unity (or 100 percent).

If the RF fields at a specific location are composed of four frequencies and their fields represent the percentages of the applicable MPE for Occupational/Controlled environments as identified by the FCC are shown below, the resulting exposure can be expressed as 85% of the allowable Occupational/Controlled MPE and continuous exposure would be in compliance with the FCC limits. An example is shown below.

Frequency (MHz)	Measured Power Density	MPE
155.025	0.25 mW/cm ²	25%
465.0125	0.54 mW/cm ²	35%
955.0125	0.48 mW/cm ²	15%
851.0125	0.28 mW/cm ²	10%
Total Exposure:		85%

Different limits apply to different circumstances (see Figure A-1), based on whether a person at or near a specific site knows or is informed and has control of potential RF exposure. Occupational/Controlled Environment limits apply to individuals who should know that there is a potential for exposure as a requirement of employment, or as the incidental result of transient passage through areas that may exceed exposure levels beyond the General Population/Uncontrolled environment MPEs. For example, a maintenance technician who performs work on transmitters should be aware (due to training and the nature of his work) that transmitters produce RF energy. Because of the knowledge and understanding that exposure is possible, this individual would be evaluated against the Occupational/Controlled environment limits. General Population/Uncontrolled Environment limits apply to individuals assumed to have no knowledge of, or control over, their possible exposure to RF energy. If the technician in the example above brought his family to the same area, the situation would change. Because the family members would not be assumed to have knowledge or understanding of the RF environment, their exposures would be judged against the limits for General Population/Uncontrolled environments. The technician, however, would be evaluated against the Occupational/Controlled environment limits. Simple understanding or precautions can assure that RF levels at or near an antenna site do not exceed maximum permitted exposure levels. The MPE exposure levels for General Population/Uncontrolled environments are five times lower than the MPE exposure levels for Occupational/Controlled environments. The technician, in the above example, could be exposed to a power density of 3 mW/cm² from a 900 MHz transmitter while the family members could only be exposed to 600 μW/cm².

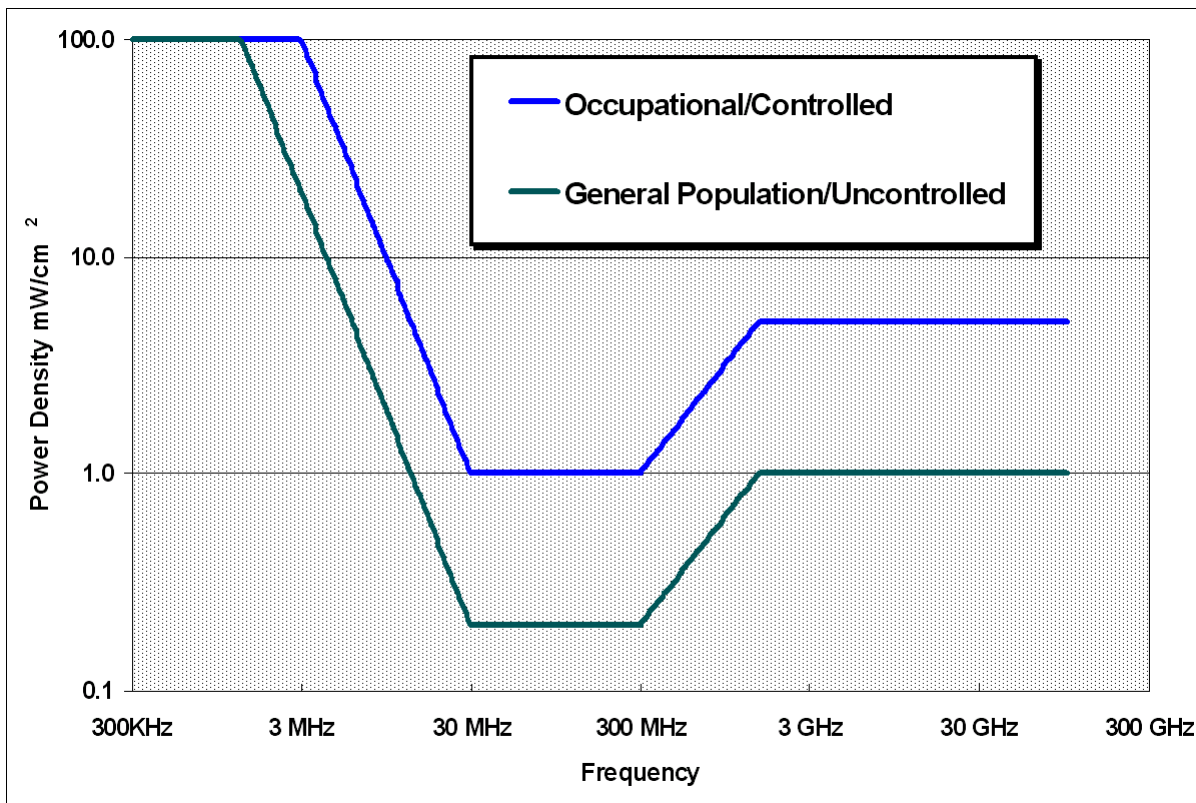

FIGURE A-1 FCC ADOPTED MAXIMUM PERMISSIBLE EXPOSURE LIMITS

A.2.2 COMPLIANCE ANALYSIS

A.2.2.1 SPATIAL-PEAK

The maximum RF energy across the area of the human body (about 1.8 m (6 ft.) high) that an individual can be exposed to, is considered the Whole Body Peak (WBP). This level should be considered as the highest level that is found in the area of interest. If, during the evaluation of an area for exposure, there are no WBP exposures above the MPE being considered, the area is considered below the limits and requires no additional evaluation.

A.2.2.2 SPATIAL-AVERAGING

If, during the evaluation of an area for potential exposure, it is determined that there are areas where peak levels (WBP) will exceed the MPE, then spatial-averaging is required. Spatial-averaging considers the whole area of the human body in the evaluation of exposure. If there is an area that has RF fields above the applicable MPE, additional vertical measurements should be taken to understand the levels between ground level and 1.8 m (6 ft.) high.¹ The average of these vertical measurements is the Spatial-averaged exposure, which is used to evaluate compliance with the MPE.

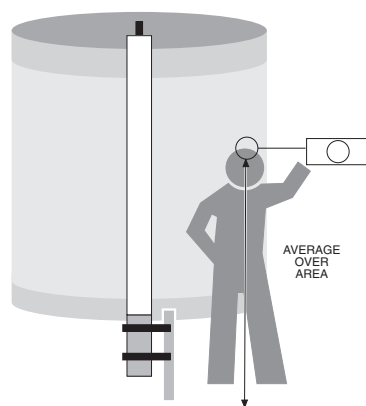

FIGURE A-2 SPATIAL AVERAGING

A.2.2.3 TIME-AVERAGING

MPEs in the guidelines are in terms of a time-averaged exposure, typically either 6-minute for Occupational/Controlled MPE or 30-minutes for General Population/Uncontrolled MPE. The averaging times are used to regulate the energy absorption rate in an individual exposed to RF fields so that the total energy delivered over the averaging time does not exceed FCC guidelines. This permits short duration exposure to much higher level fields as long as the average value over the prescribed time remains within the MPE.

1. The ANSI/IEEE C95.1 - 1992 standard uses a height of 2.0 meters.

The FCC MPE is time and spatially averaged. It is therefore permissible to exceed the numeric values of the MPE for brief periods of time and in some locations of space as long as the average exposure does not exceed the limits over the time and space indicated.

While time averaging is considered an acceptable mechanism for managing high exposure levels, it requires considerable attention and consideration. There is potential for error and thus, the use of time averaging alone generally should be avoided. If situations are encountered where levels exceed the exposure permitted with spatial-averaging, then other means **shall** be utilized to reduce exposure. There are situations however, where time averaging may prove to be an acceptable method available to control exposure. One of these situations is tower climbing. While on a tower, a climber may move through fields that are in excess of the limits for continuous exposure. If a steady rate of ascent is maintained the time-weighted averaged exposure can be maintained below the limit allowed in the guidelines.

A.2.3 EXPOSURE EVALUATION

Evaluating possible RF exposure levels can be done using both theoretical models and physical testing. Modeling a site allows the tester to be aware of situations and anticipate locations where close physical examination is required.

The maximum exposure allowed by the FCC limits is 100% of the MPE, averaged over both time and body height. To provide a margin of tolerance to ensure compliance, in many cases an additional factor of 3 dB or 50% should be adopted as an action threshold. Any levels above 50% of the applicable MPE **shall** have action procedures to maintain compliance.

A.2.3.1 RF MODELING

Modeling is the theoretical calculation of RF fields based on the situation. With a minimum amount of data, the field strength can be estimated before actual testing begins. To fully apply modeling, the characteristics of the antenna radiating in free space must first be understood. The field radiates from an antenna like a ripple in the water after a pebble is thrown. The closer to the source, the more curved the wave front will be; further from the source the circle becomes very large and the wave front has less curvature. Far from the source, the field appears planar. The field will still be curved but within the limits of observation it appears to occupy a flat plane in space, e.g., plane-wave radiation.

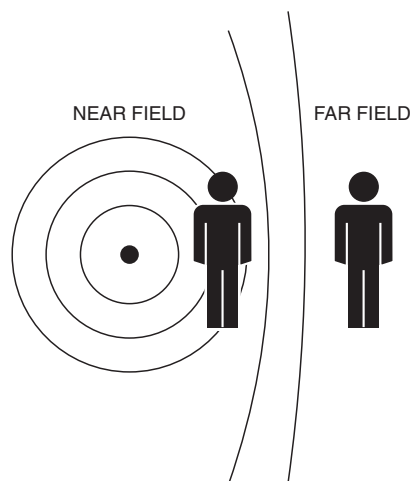

FIGURE A-3 RF MODELING

Close to the antenna is a region referred to as the **near field**. Within this region the spatial characteristics of the RF fields are very complex. The average power density within the near field varies inversely with the distance from the antenna. In other words, as distance from the antenna increases, the power density is reduced inversely with distance, D . This is the so-called **$1/D$** region.

Further from the antenna is the **far field**. In the far field, the beam has developed and propagates in a behaved manner. In the far field as distance from the antenna increases, the power density decreases inversely with the square of distance. This is the so-called **$1/D^2$** region. This signal intensity characteristic is commonly used to predict coverage. Far field calculation of signal strength is the normal approach for estimating signal strength a mobile receiver will receive.

From the standpoint of anticipating the power density to which a person will be exposed from an antenna, both the near and far fields must be understood. If RF levels are predicted very near an antenna based on the square of the distance (as is indicated in the far field formula), the calculated levels increase faster than what really occurs close to the antenna. There is a point called the crossover point where the two fields meet. Before this point the power density drops off linearly and after this point the signal reduces as an inverse square relationship. If both formulas are considered, there is a point of intersection. This crossover point is defined as the boundary of the near field and far field.

The power density decreases much faster in the far field than the near field. There is a distance from the antenna where the field strength of near field and far field are equal or intersect. The point of intersection (crossover point) is the boundary for the two zones.

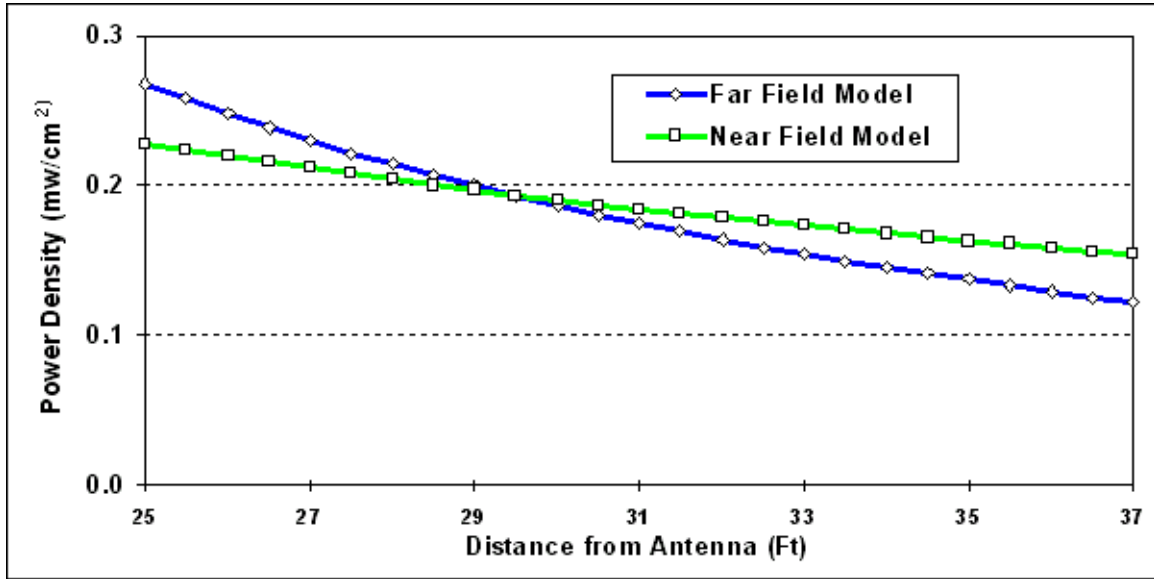
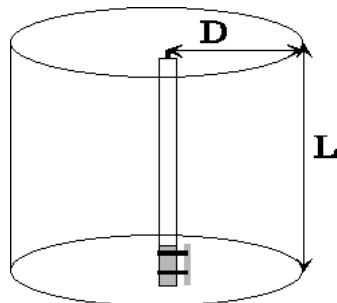

FIGURE A-4 EXAMPLE OF NEAR FIELD/FAR FIELD CROSSOVER

The data in Figure A-4 represent the crossover for a 6 dBd gain omni antenna that is 2.74 m (9 ft.) in length. As the aperture length and gain change, the crossover point will also change greatly. For the example above, the crossover point is approximately 9.14 m (30 ft.). For an antenna with 10 dBd of gain and an aperture length of 3.96 m (13 ft.), the crossover point will be over 30.5 m (100 ft.). A 3 dBd gain antenna with an aperture length of 457 mm (1.5 ft.) will have a crossover point of only 914 mm (3 ft.).

A.2.3.1.1 CYLINDRICAL MODEL

For vertical antennas, with omnidirectional horizontal patterns, the power density in the near field can be estimated using the circular radiation pattern and the height of the antenna. The area of a cylinder placed over this antenna is assumed to be uniformly exposed to the power radiated by the antenna; no RF energy emanates from the top or bottom. This power density is approximately the same as the average power density an individual of a specific height would be exposed to when standing next to the antenna. This formula is referred to as the Cylindrical Model because it utilizes a cylinder for the modeling (see Figure A-5).



$$S = \frac{P}{2\pi DL}$$

- S = Power Density (mW/cm²)
- P = Total Power into Antenna (mW)
- D = Distance from Antenna (cm)
- L = Length of Antenna Aperture (cm)

FIGURE A-5 CYLINDRICAL MODEL

Shorter antennas result in higher fields and exposure for a constant power. The greater the power, the higher the EME field. The shorter the aperture, the higher the EME field. The closer to the antenna, the higher the EME field.

A.2.3.1.2 SPHERICAL MODEL

In the far field, the radiation pattern becomes developed and does not change with distance from the antenna. The maximum radiating power density becomes related to the gain of the antenna. In the far field, the power density decreases as the square of the distance. With an isotropic point source (omnidirectional in all directions) the power density can be envisioned as the source power distributed over a sphere having a radius equal to the distance from the antenna. When the antenna has gain, the maximum power density in the far field can be calculated using the formula below:

$$S = \frac{PG}{4\pi D^2}$$

S = Power Density (mW/cm²)

P = Total Power into Antenna (mW)

G = Gain Ratio of Antenna based on an Isotropic radiator

D = Distance from Antenna (cm)

A.2.3.2 ROOFVIEW™ EME MODELING SOFTWARE

¹RoofView is a modeling software package that allows a theoretical study of site situations. The software creates a mosaic map of the area showing the EME levels (see Figure A-6). The calculations can use different methods, different standards, antenna heights, and uptime for evaluation. There are two versions:

- **RoofView** is the building version showing EME situations on a single plane.
- **TowerCalc** is used to model towers. This will allow the EME situation on any level of the tower to be understood.

The software runs on Excel 5.0 for Windows 3.1 and NT and Excel 7 for Windows 95. The information needed to create a model and generate a zoning map is:

- Transmitter Power into Antenna
- Frequency
- Antenna mount designation

1. Trademark RoofView™ and TowerCalc™ are licensed to Richard Tell Associates, Inc., Las Vegas NV. Additional information can be found on Website: www.radhaz.com

- Antenna location on roof
- Antenna Characteristics
 - Gain
 - Aperture Length
 - Mounting Height

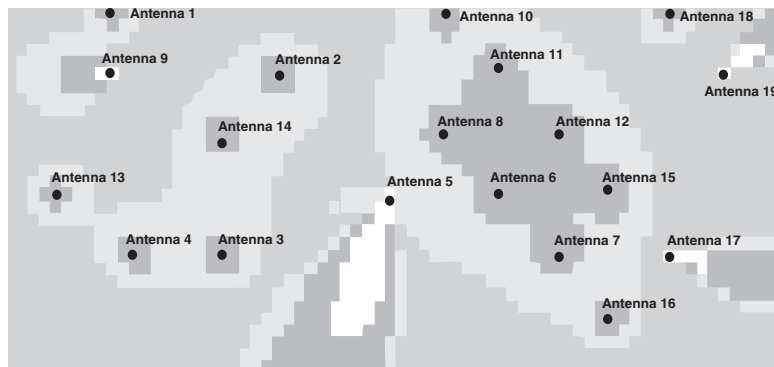

FIGURE A-6 EME ZONE MAP OF A COMPLEX ROOFTOP ANTENNA SITE

RoofView calculates and plots a pictorial representation of EME levels. Antenna fields can be expressed directly as a percentage of user selectable MPEs. This is analogous to running a range prediction coverage map. During RF system design an understanding of coverage is important. During site design EME evaluation is important.

A.2.4 EME ZONING

After the exposure levels are determined an evaluation and classification **shall** be performed. The classifying of the exposure allows site managers to understand the complete situation and develop procedures to ensure exposure to employees and contractors is maintained below the acceptable limits.

Classifying exposure focuses on comparing the levels found against the Occupational/Controlled MPE. As the term indicates, MPE is the maximum permissible exposure an individual should encounter. To further classify areas, a standard color coding can be adopted to clearly show the EME levels.

On a site where RF transmitters and their associated antennas are located, it is usually necessary to restrict the access of the general population. This area frequently is bounded by walls, fences, and other natural or man made structures. Within this area three zones (Green, Yellow, and Red) will be used to determine the requirements for compliance to the FCC guidelines.

A.2.4.1 GREEN ZONE

The green zone is any area where the time (as appropriate) and spatial-average is below 20% of the Occupational/Controlled MPE. The areas so classified afford the highest level of protection for individuals working in RF fields. There is no time limit and no special EME safety practices are required for these areas. Individuals working in this zone may need only basic EME awareness. This can be conveyed with signs, plaques, or awareness videos to provide the information necessary to create an awareness and understanding of the environment.

Green Zones denote the lowest EME levels at the site. This area is usually associated with equipment rooms, ground areas around towers, and other areas significantly removed from transmitting antennas. The green zone is unique because the exposure levels are below the General Population/Uncontrolled environment MPEs. Care and proper consideration in site design **shall** be done to ensure these levels are maintained. On high-density sites annual (or more frequently if required) evaluations **shall** be done to ensure compliance.

Equipment rooms and areas around the base of towers **shall** always be required to have fields low enough to allow a green classification. The verification and certification of this low level may be required on some sites. If locations are discovered in excess of these levels, changes and modifications must be incorporated to maintain green-zone status. Some methods to maintain green-zone levels are:

- Proper maintenance of RF transmitters. This includes ensuring all shields are maintained properly and installed correctly.
- Not allowing transmit antennas inside equipment rooms or near the ground level of sites.
- Ensuring all microwave dishes are directed away from facilities.
- Proper use and installation of transmission lines and connectors. When waveguide carrying high power is used, verification of fitting integrity must be performed to ensure there is no RF leakage.

A.2.4.2 YELLOW ZONE

The yellow zone is any area where the spatial-average is between 20% to 100% of Occupational/Controlled MPE. While the fields in this area are within acceptable limits, caution must be exercised because nearby locations may exceed the limits. Therefore, individuals in these areas should have heightened awareness and understanding of their potential for exposure. Normally, there will never be a yellow zone without another zone of higher level in the vicinity. Personnel without EME awareness training **shall not** frequent this area regularly. Only personnel with the proper knowledge and understanding of EME compliance procedures **shall** be allowed to work in areas designated as yellow zones. Appropriate Caution signs **shall** be posted to inform personnel of the EME situation.

Yellow zones **shall** be posted to ensure all personnel entering understand the area is controlled. The EME levels in a yellow zone are below the MPE for Occupational/Controlled environments, but not for General Population/Uncontrolled environments. **Only** individuals who have the knowledge and requirement **shall** be given access.

A.2.4.3 RED ZONE

The red zone is any area where the spatial-averaged levels fall above 100% of Occupational/Controlled MPE. When locations are found to require red zoning, special procedures, engineering, or restricted access must be implemented to ensure compliance. Some procedures that can be implemented are:

- Restrict Access
- Lock-out/Tag-out of transmitters during maintenance of antenna system
- Control of antenna types used for site design
- Re-engineer site to reduce EME fields
- Measure and consider uptime. (“Uptime” is the percentage that a transmitter will likely be keyed. See “Uptime,” on page A-18 for detailed information.)

A.2.5 CHARACTERIZATION ZONING

The level of RF energy to which one is exposed is called Exposure. The quantity of exposure depends on the duration and strength of the field. In most cases, the characteristics of a site will determine the EME exposure potential. Understanding these characteristics will aid in predicting and preventing levels that exceed the FCC Guidelines and allow the site manager to establish the proper procedures for personnel who frequent these areas.

A.2.5.1 BUILDINGS

Building sites are normally in dense, metropolitan cities. The buildings used are normally the highest structures in the city and offer the unique opportunity of height without the need for a long feedline. The facility which houses the radio transmitters is normally close to the antennas which reduces the loss between the antenna and transmitter, allowing maximum power to the antenna. While this maximum power provides extended range, it increases the EME levels around the antennas. The main determinants of EME are frequency, power into the antenna, and aperture height. The greater the power, the higher the EME field. The shorter the aperture, the higher the EME field for a given power.

On buildings, the antennas are generally mounted on the roof. This mounting arrangement is normally laid out on a single plane and distributed in a grid arrangement, within the confines of the roof. The mounting is normally on a pipe structure and the separation can be as close as 914 mm (3 ft.) in some cases. This arrangement provides for maximum mounting density, but it may leave little space for the workers performing maintenance. Any worker attempting to change an antenna, repair a cable, or perform general maintenance may be exposed to high levels of RF energy from other antennas surrounding the work area. Proper engineering design should be used to prevent this situation. By reducing all the fields on a building the potential for high exposure is eliminated and provides the best compliance resolution.

A.2.5.2 TOWERS

Towers are antenna supporting structures that can be found in various locations ranging from central metropolitan, to isolated rural locations. Normally, the towers are designed to elevate the antennas in accordance with the intended coverage area. This can vary from 30.5 m (100 ft.) for cellular to 610 m (2000 ft.) for two-way communications. Regardless of the height of the supporting structure, the characteristics are the same. The application of the antennas that are being supported determine these characteristics. Cellular towers usually have directional antennas mounted on a single face to define a sector. There may be several faces and several directional antennas per face. A two-way tower can have several antennas mounted in a star configuration to maximize the density of antennas at a position on the tower. Additionally there can be several star mounts on a single tower.

With respect to EME, the cellular configuration presents less exposure to people working on the tower than the two-way tower configuration because the RF radiation of the directional antenna is aimed away from the tower. There is a significant power difference between the front and the back side of the antenna. This difference is called front-to-back ratio. While the front-to-back ratio can be as great as 25 dB in the far field it is less well developed in the near field. There is still reduction of the exposure of the worker in the near field behind, as compared to the front of the antenna, but the amount may be considerably less than the advertised far field front-to-back ratio.

The situation on two-way towers is significantly different. As workers climb up the tower they may encounter several antenna mounts at various locations on the tower. These mounting areas can contain various types of transmitters ranging from paging transmitters with hundreds of watts of power to large antennas for transmitters in the 35 MHz frequency range. While the antennas and the resulting mounting arrangement can be considerably different, in some conditions the EME levels may approach or exceed the FCC guidelines. In the case of the paging transmitter, the antenna will normally be an omni configuration with an aperture length of 1.2 m to 4.6 m (4 to 15 ft.). The antenna will be mounted from 1.2 m to 1.8 m (4 to 6 ft.) from the tower. Fields directly adjacent to the aperture will present the highest levels. Because of this, workers **shall** use caution while working or stopping directly in front of these antennas unless the transmitters are deactivated. If the antenna is grouped with other antennas at the same level more than one transmitter may need to be deactivated. Another important characteristic of paging is the duty cycle of the transmitter. The importance of duty cycle will be discussed in detail later.

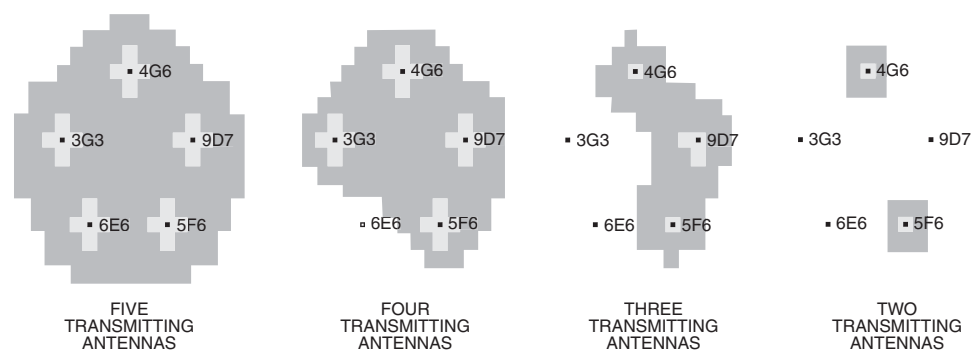

FIGURE A-7 EME ZONE MAP OF A TOWER MOUNTED STAR CLUSTER MOUNT OR CANDELABRA (RESOLUTION 1 SQ. FT.)

Star cluster mounts (see Figure A-7) or candelabras present a significant issue in the management of EME on towers. If there are five to eight antennas mounted in a circle and these antennas are located 1.5 m (5 ft.) from the tower, there is the potential for an EME level in the center that exceeds the limits. Because the center is the tower, workers must ensure they understand the fields while entering this area. Figure A-7 shows the computed effects of several transmitters using the EME modeling program described above. Each square pixel represents 929 cm² (1 sq. ft.) of resolution. This simulates the effects of five PD-10017 antennas with 100 W into the antenna at 900 MHz. A worker entering this area may be exposed to EME levels above the applicable MPE and **shall** take appropriate steps, such as moving quickly through the area, to assure compliance with recognized exposure guidelines. What makes this situation difficult to manage is the fact that the field and the resultant high EME levels from all the antenna fields overlap and add. While this situation can exist, the fields are reduced by the cable loss associated with the height of the candelabra, and are therefore more manageable. Most candelabras are mounted on top of a tower.

Because of the cable loss associated with towers, the power into the antenna is significantly lower than buildings and hilltop sites. This loss between the transmitter and antenna reduces the power and ultimately the fields produced. Higher frequencies have higher line loss, which significantly reduces the power at the antenna. This fact is very important and proves to significantly reduce the fields produced on tall towers.

Candelabra and star mounts present unique compliance and maintenance situations due to the additive nature of EME exposure at these locations. Insertion losses of transmission lines reduce the power into the antennas and reduce the likelihood of strong fields on clusters located at high levels on tall towers. For equal transmitter power, the higher the frequency, the higher the insertion loss; thus EME levels are lower on tall towers.

A.3 ENGINEERING CONSIDERATIONS

A.3.1 ANTENNA ELEVATION

One common technique for reducing the RF levels expected on large roof tops is to elevate the antennas above the roof. Elevating the antennas raises the EME fields above the roof and reduces the power density to which an individual at roof level will be exposed. The results of elevating antennas are illustrated in Figure A-8. These data are based on the EME fields produced by an 850 MHz SMR antenna. Ten 150 Watt transmitters through a combiner drive the antenna. The resultant 550 Watts of power is fed into a 3.96 m (13 ft.) omni antenna. This type of antenna configuration is not unusual on rooftops.

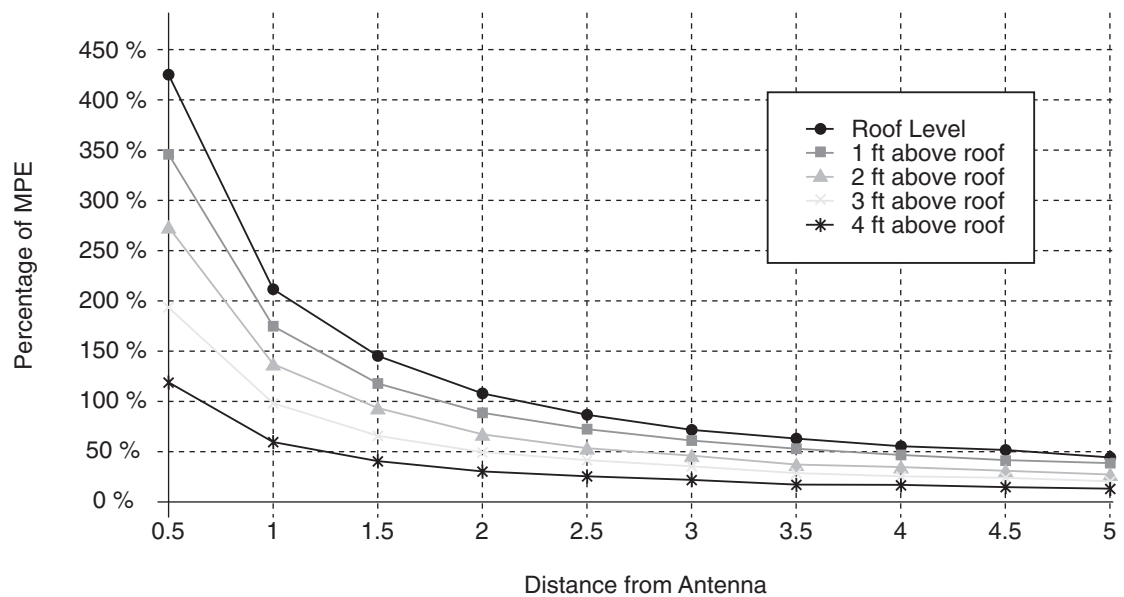

FIGURE A-8 EXPOSURE VS. ANTENNA HEIGHT ABOVE ROOF

The resultant exposure possible can be above the MPE when the antenna is mounted at the roof level. From the chart, fields in excess of 200% of the Occupational/Controlled MPE are encountered within 305 mm (1 ft.) of the antenna. While this seems extremely close, a technician walking down the center of an antenna grid with 1.2 m (4 ft.) centers will be 610 mm (2 ft.) from any antenna at any time. At a distance of 610 mm (2 ft.) from this antenna mounted at roof level, it is possible for the exposure to be over 100% of the same MPE. If this situation is compounded with several antennas having the same power density, the levels in this walking area could be above the MPE. For this reason every effort should be given to reducing the fields at the roof level. The most effective technique for reducing the fields on a building, while maintaining constant radiated power, is raising the antenna. Raising the antenna 1.2 m (4 ft.) above the roof reduces the EME field strength at the roof level to about 50% of the MPE at 305 mm (1 ft.) from where the antenna was. If the antenna is raised 1.8 m (6 ft.) above the roof the fields are reduced more than 90%.

The most effective technique for reducing EME levels is elevating antennas on buildings and extending antennas away from the tower.

A.3.2 EXTENDING ANTENNAS AWAY FROM TOWERS

Tower contractors climbing the tower must pass through fields created by active antennas on the tower. Antennas mounted on short sidearms or mounted directly to the tower produce high levels of exposure to tower climbers. It is a good engineering practice to mount omnidirectional antennas a minimum of 1.52 m (5 ft.) from the tower.

A.3.3 COLLOCATED BROADCAST TRANSMITTERS

Areas with broadcast transmitters can have fields created by grating lobes from the antenna or fields developed directly by the main radiating beam. On broadcast-only sites these are the only field that must be considered in EME analysis. On collocated sites, the EME fields are a combination of the fields generated by two-way transmitters and broadcast stations. If the exposure from each contributor is considered independently and then added, the total MPE situation can be evaluated. The fields from the broadcast transmitter act like a blanket covering the area. If the fields from a preexisting broadcast station create a level of 15% Occupational/Controlled MPE there is only 85% of the MPE budget remaining. This requires the levels from the two-way transmitters to be lower than what otherwise would be required to maintain compliance. In some conditions extra cooperation between the broadcasters and two-way licensees may be necessary to ensure site compliance. In the areas that receive grating lobes from the broadcast transmitters, careful measurements must be done before compliance can be analyzed.

Consideration must be given to anyone working on antenna systems. If a person must climb into the fields of the broadcast antenna, coordination ahead of time must be done to reduce the transmitter power. Special consideration and care **shall** be utilized when a person is required to climb through a field known to exceed 100% Occupational/Controlled MPE. On some sites the broadcast towers are mounted adjacent to the two-way tower. In this situation the fields from the broadcast transmitter will be very intense on the two-way tower. Maintenance activities must be coordinated when the broadcast station is collocated. The FCC requires broadcasters to cooperate during maintenance situations; however, they may elect special times to conduct maintenance.

A.3.4 LOCATION OF DIRECTIONAL ANTENNAS

Directional antennas in the horizontal plane present a focused pattern for maximum coverage into a specific area. Even in the near field the levels in the beam of the antenna can be significantly higher than behind or on either side. Consideration must be given to the area and location the antenna is directed. Directional high-powered transmitting antennas should be located where the energy in excess of the Occupation/Control MPE is directed away from any area frequented by workers. Additionally directional antennas **shall not** be installed where they can produce fields higher than the General Population/Uncontrolled MPE in uncontrolled areas.

A.3.5 ANTENNA SELECTION

Antenna selection is important because it is directly linked to EME levels. The requirement for more antennas within a given horizontal space has created new designs of antennas. Within one radome several antennas can now be stacked on top of each other. The standard configurations are double (two), triple (three) and Quad (four) co-linear arrays. Aperture length directly affects the power density created. In the near field, a 4.6 m (15 ft.) antenna driven with 500 Watts will have one-third the power density of an antenna 1.52 m (5 ft.) long. Remember that near the antenna, the power density is related to the surface area of a cylinder placed over the antenna. A cylinder having one-third the height will have one-third the surface area and, hence will result in three times the power density. This is complicated even more when the 1.52 m (5 ft.) antenna is placed with other antennas in a common radome. This allows the power density, created by each antenna, to combine and increase the potential exposure of an individual. The technique of using triple and quad antennas is becoming increasingly popular as the space on hilltops and towers becomes scarcer. Paging transmitters, sectored antenna systems, and digital networks represent only a few of the services requiring individual antennas. There is a finite antenna density that can be accomplished within a given area. Creative methods of combining or increasing the antenna structures must be developed. Consideration should be given to connecting lower power transmitters to the bottom portion of triple and quad radome antennas.

A.3.6 MOUNTING DENSITY OF ANTENNAS

While the RF fields from one antenna may be below the MPE allowed, the combination of fields from several antennas can produce levels exceeding the Occupation/Control MPE. This can be easily seen in Figure A-9 and Figure A-10 which show the fields produced by one antenna and the fields produced by five antennas mounted at roof level with all transmitters keyed simultaneously.

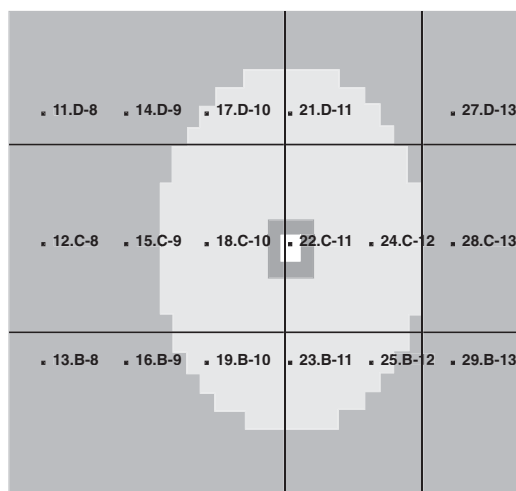

FIGURE A-9 COMPOSITE RF FIELDS WITH ONE ANTENNA TRANSMITTING

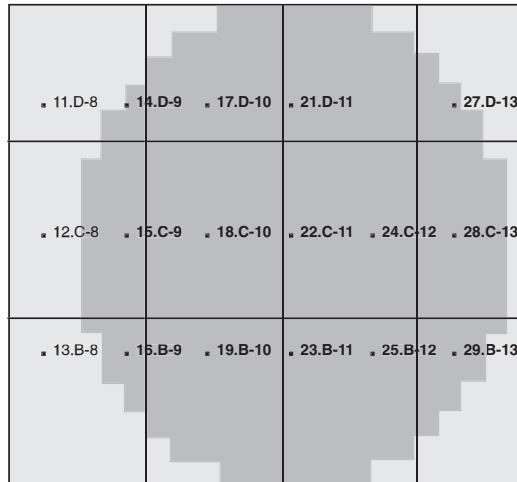

FIGURE A-10 COMPOSITE RF FIELDS WITH FIVE ANTENNAS TRANSMITTING

The combined fields produce levels exceeding the MPE allowed in all areas surrounding the antennas. In these situations, some means of controlling exposure must be used. These techniques may include RF protective clothing, re-engineering the antenna system, or power shutdown or reduction when working in the area. While power shutdown or reduction may appear to be an effective technique, either may be impractical for wireless communications services. It is normally reserved for broadcast transmitters. One preferred method of addressing this is to elevate the antennas above the roof area.

A.3.7 UPTIME

Complex antenna sites have a “personality” that makes them unique. The personality of the site is not only determined by the RF power, frequency, and manufacturer of the equipment, but by the operational characteristics. The RF level and frequency can be determined by understanding the equipment specifications, but operational characteristics can only be quantified by monitoring the usage. Because of the high number of pagers, paging transmitters will have a very high transmitter duty cycle. Trunking (SMR) transmitter activity will depend on customer loading density. This can range from transmitters rarely transmitting, to transmitters rarely not transmitting. Private customer equipment will have a very diverse usage characteristic that can not be predicted. The important point in understanding the characteristics of different services is that they can seldom be predicted.

Additionally, characteristics for transmitters will change due to cultural elements. Transmitters located in Las Vegas will have considerably different uptime characteristics than transmitters located in San Antonio, Texas or New York City. Tests have shown that a site will vary significantly from one time period to another. Sample measurements on a roof of a large building showed a variation in transmitter activity of over 30% between 11:00 a.m. and 2:00 p.m.

Uptime relates to all of the transmitter activity of a site. Uptime can seldom be predicted or characterized precisely, and thus usually must be measured. The amount of Uptime directly affects the EME exposure levels on a site.

In the consideration of site activity, there is an upper level of 100% uptime, or when all transmitters are keyed and actually energized. Actual usage would be the most accurate consideration, but least practical to implement. Actual usage varies greatly over time and antenna. Each antenna has an uptime characteristic based on density of combining, transmitter usage, and activity.

While the use of Uptime could provide a better approach to predicting the actual levels that could be encountered, it proves to be impractical. Determining the Uptime characteristics can be very complex and change with time. Only by constantly monitoring and adjusting the model can uptime be used. Uptime cannot be theoretically calculated, it must be measured. Measurement of uptime involves high speed scanning of frequencies over a long period of time. Only after thousands of activity observations taken over days of monitoring will the worst case, actual, and instantaneous uptime be understood. This complex procedure creates uncertainty. Practically, the uptime that should be used in the analysis of complex sites usually is 100% or total uptime.

A.3.8 ANTENNA SITE DOCUMENTATION

Any evaluation is only as accurate as the data used to make the evaluation. Antenna site documentation is important and **shall** be done in a standardized manner. For the analysis of EME fields, there are two methods of documentation. One proves to be considerably more exact but both allow an engineer to understand the EME situation and apply the proper compliance procedures, if necessary.

A.3.8.1 ACTUAL DOCUMENTATION

Actual documentation provides an accurate picture of the site situation. Actual documentation can be used by engineers for purposes other than EME analysis. Proper documentation requires a detailed description of transmitters, cable, antennas, and location on the tower. Specifically, the following information is required:

- Transmitter frequency by antenna mount
- Power out of transmitter
- Network loss between transmitter and antenna
- Antenna characteristics and specifications
- Antenna location and standoff
- Uptime characteristics
- Areas frequented by personnel
- Layout of antenna field (roof or tower)

A.3.8.2 CATEGORIZATION DOCUMENTATION

Determining which transmitter is connected to which antenna on a site via which coaxial cable can be very expensive and in many cases is not necessary. Categorization documentation evolves determining the lowest loss coax and the highest-powered transmitter in any particular band. It is then assumed that all antennas for that band have this combination attached. By understanding the frequency, spacing, height and antenna characteristics of all antennas on the tower an approximation of the worst case EME situation can be determined. If this preliminary investigation proves to be compliant, then the actual situation will be compliant. Thus, this worst case scenario evaluation will assist in determining if a more detailed evaluation is required. This method of EME analysis requires a trained site auditor to only determine the components affecting EME compliance. This procedure will not provide the exact levels of the fields, but can be used to determine sites that require additional investigation using actual documentation.

Understanding the EME environment for a given site requires that an inventory of all generators of RF energy and the EME exposure potential be maintained for all facilities. This requires standardized documentation practices and regular updating.

A.4 WORK PRACTICES

The way an antenna site is managed, controlled, and operated directly relates to the quality of the site. All of the customers on a site not only have physical investments, but also rely on uninterrupted service. The requirements placed on all contractors, customers, and employees determine the quality of a site.

A.4.1 TRAINING AND QUALIFICATION VERIFICATION

A very specific part of worker contracting is verification of qualification and training. All contractors **shall** have a basic understanding of EME awareness and show an understanding of site standards. All contractors are expected to be experts in their field and to be fully aware of changes in governmental regulations. Without regular training a contractor cannot expect to be fully aware of changing hardware, technology, and government regulations.

A.4.2 PHYSICAL ACCESS CONTROL

Antenna sites must have physical access control. The minimum requirement is locked gates to prevent vehicular access, and locks on the facility. In most situations towers should have specific access control. Access to the site **shall not** allow access to the tower. Tower climbing prevention **shall** be accomplished with fencing around the tower, climb prevention on the tower, or locking barriers on the tower. Unauthorized climbing must be prevented to ensure individuals climbing a tower understands the EME situation, are qualified, and possess the correct climbing equipment. The facility should be equipped with card access, where appropriate, to provide a direct history of traffic at the site. Card access will provide specific information on who comes and goes from the site.

A.4.3 POLICING

Any policy controlling site administration must be enforced before compliance can be assured. Every effort **shall** be given to ensuring all contractors understand, comply and support the policies of the site. Violation of policy **shall** be grounds for disqualification of a contractor. It is a privilege to work on a site and the policies must be followed.

A.4.4 CHAIN OF AUTHORITY AND REPORTING REQUIREMENTS

There should be site books or a site folder located at each facility. These documents will outline the policies and procedures for the site including a contact roster for emergencies and notifications. Additionally, any specific site situations or policies can also be contained in the site book.

A.4.5 UNDERSTANDING SITE RESPONSIBILITIES UNDER SHARED CONDITIONS

There are situations where occupancy and management of a site involves other agencies or entities. This may be a situation where a site is located on a building, collocated with broadcast companies, shared hilltop, etc. In each of these situations, others can make decisions that can affect the safety and operation of the site. Every effort should be given to developing consolidated procedures that require the compliance of all parties. This protects their interests and safety as well as contractors and employees using the site. Control measures **shall** be coordinated to allow safe tower maintenance. When other transmitters are involved, power reduction, lock-out/tag-out, or restricted time for maintenance may have to be used to assure RF exposure is controlled.

A.4.6 GENERAL PROCEDURES

General procedures relate to normal practices that are common to all sites. These can be found posted at all sites on the “Guidelines for working in radio frequency environments” placard. These guidelines are:

- All personnel **shall** have electromagnetic energy (EME) awareness training

All workers entering a RF controlled area **shall** understand their potential exposure and steps they can take to reduce their EME exposure. Awareness is a requirement of all workers. This includes not only field engineers, maintenance technicians and site designers, but also others such as site acquisition personnel, building management, and service oriented personnel (such as electrical, telephone, elevator and air conditioning mechanics as well as roof repair, painting and window washing crews). The FCC report and Order specifically indicates the requirement to make personnel at a transmitter site “fully aware” of their risk of exposure. Awareness training increases worker sensitivity to potential exposure, thereby assisting proper compliance regarding exposure limits. Awareness can be given in different formats, some may be video, formal classroom, and informal discussions.

- All personnel entering this site must be authorized

Only personnel who have been trained and understand the EME situation and other safety requirements associated with site work **shall** be allowed access without escorts. When untrained individuals access the sites, trained escorts are required.
- Obey all posted signs

This guideline emphasizes the importance of observing and understanding the instructions on posted signs at the transmitter site. All safety signs play an important role in any safety program and just as any of these signs convey a specific message related directly to safe work in a particular environment, postings at transmitter sites are no different. For example, certain areas may be designated “NO ACCESS” unless certain antennas are shut down. It is important that these signs be understood and obeyed, to assure EME exposure below the FCC guidelines. The requirement for RF protective clothing for workers is another precaution that could be identified on signs designating areas of potential exposure in excess of FCC limits.
- Assume all antennas are active

Because most telecommunications transmissions are intermittent, the status of many transmitters that may be operating at a particular site will be unknown. It is important to assume that all antennas may be energized and to maintain a safe working distance from each of them. Only with special instruments to detect the presence of RF energy can it be determined a particular antenna is not energized at any given moment. While EME measurement surveys may have been performed on the site, these surveys do not assure that a specific antenna is not active at a given time.
- Before working on antennas, notify owners and disable appropriate transmitters

Before working on an antenna, workers must ensure that all attached transmitters are deactivated. Most antennas at a transmitter site are being used for important communications. They may be used for emergency and safety purposes like fire protection, rescue dispatch and police communications. Although all attached transmitters must be turned off before touching and working on an antenna, in any case touching or working on an antenna **shall not** be attempted before contacting the owners or operators. Coordinating with the individuals responsible for use of the transmitter will make sure that turning off the equipment will not cause a serious disruption of the service. Sometimes, this coordination may mean that the work will have to be performed at night or in the early hours of the morning. Lockout/Tagout tags should be used to make sure someone else does not inadvertently turn on the transmitter while work on the antenna is being performed.
- Maintain minimum 914 mm (3 ft.) clearance from all antennas

Studies have shown that the EME fields close to two-way radio transmitting antennas can be strong enough to exceed the limits specified by the FCC guidelines. A 914 mm (3 ft.) clearance is a practical approach to assure that exposure remains within FCC limits. This ensures a distance is always maintained unless work is required on an antenna. Work on a **specific** antenna **shall only** be accomplished after the attached transmitters have been turned off. A small increase in distance from an antenna can have a substantial effect on reducing the EME exposure. This is particularly important when working near other active antennas. This also applies when doing work on roof or tower mounted equipment like air conditioners, tower lights or window washing rigs.

- Do not stop in front of antennas

When moving about at the transmitter site workers **shall** avoid stopping near any antenna; they should continue on until they reach an area that is removed from their immediate vicinity. If they are going to take a break from work, or have lunch, they should select a place on the roof that will provide as much distance between them and the nearest antennas as practical. When climbing a tower, workers should select rest points away from antennas. Workers should always try to keep below or behind antennas to minimize their exposure to the main beam of the antenna. By continuing to move past high EME fields the average exposure will be minimized.

- Use personal RF monitors while working near antennas

Special care must be exercised when working on or very near antennas. Although the EME fields cannot be sensed directly, transmitter activity can be detected close to an antenna with a personal RF monitor. Wearing such a monitor will allow workers to ensure that all connected transmitters have been turned off before they begin maintenance. As they approach an antenna, if the monitor alarms, they **shall** get away from the antenna, determine which transmitters are still on and disable them.

- Never operate transmitters without shields during normal operation

Some work at antenna sites involves troubleshooting and repair of the radio transmitters. The shields within transmitter power amplifiers are there to prevent strong RF fields from radiating out of the transmitter cabinet. Operating the transmitter without shields could cause interference and exposure of the technician performing the service to EME levels in excess of the FCC guidelines. While shields must be removed for many maintenance tasks, they **shall** always be properly reinstalled before returning the transmitter to normal operation.

- Do not operate base station antennas in equipment room

At any time, transmitting antennas **shall not** be operated inside the equipment rooms, even for short term testing. This includes mobile magnet mount antennas attached to the top of transmitter cabinets as temporary installations. Using transmit antennas inside equipment rooms can increase the exposure to EME levels above FCC guidelines and create undesirable radio frequency interference.

A.4.7 SITE SPECIFIC PROCEDURES

Site specific procedures that are unique to a particular site may need to be available to assure compliance to the FCC Guidelines. These can include:

- Special access
- Potential high EME exposure situations
- Special maintenance procedures for antenna repair
- Maintenance procedures unique to the site
- Special security procedures
- Special reporting procedures related to other tenants and owners

A.4.8 OPERATING PROCEDURES

The conduct of contractors should be controlled and coordinated by the antenna site manager. All contractors, whether customer controlled or contracted directly with the management, must follow specific procedures. These procedures relate to safe operations that will be followed during installation and maintenance of antenna systems. Site procedures will prevail over contractor accepted practices and standards. Contractors must follow the guidelines for the site.

A.5 SIGNAGE

Various signs may be required on antenna sites. The minimum requirement is to post an EME caution and/or warning signs, as appropriate, wherever EME levels can exceed those associated with a green zone. This sign **shall** be posted in a location that can be easily viewed by individuals that enter the areas of concern. Some areas that may be effected are building tops, towers, areas around broadcast, etc. This assures notice and understanding that the area has active RF transmitters. The sign **shall** conform to the ANSI standards.

Posting of signs provides a convenient method to convey to individuals important information. While signs can be effective if used properly, they can convey the wrong message and create undue alarm if used incorrectly. For this reason different signs are recommended for specific applications. These signs represent the best methodology available in conveying important information.

The standards used in creating these signs are:

Signal word- This word designates the degree of safety alerting, e.g. Warning, Caution, and Notice.

Symbol - The advisory symbol for identifying incident electromagnetic energy consists of black wavefronts radiating from a stylized point source. This symbol is defined in NEMA/ANSI Z535.3-1991.

Text Message - The text message **shall** convey three things:

- What the safety issue is
- What action should be considered
- What authority the issue is based upon

These are used to designate the possible issues that can be encountered at an antenna site. These signs have specific implementation guidelines as outlined below. Improper implementation could result in inaccurate information being conveyed or unnecessary alarm being created.

Examples of signs that have been implemented in the United States are shown below.

- Site Guidelines

The site guidelines are posted inside the equipment room to make all workers aware of the normal requirements for site operation. The major intent is to ensure that compliance is maintained at the site. Having the sign visually available informs and reminds all personnel and others who have proper access of the rules for the site. This also qualifies as awareness information.

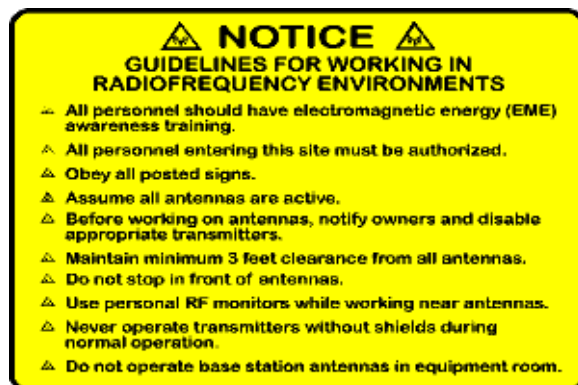

FIGURE A-11 SITE GUIDELINES PLACARD

- Notice

The notice sign is used to distinguish the boundary between the General Population/Uncontrolled and the Occupational/Controlled areas. This boundary will usually be the fence for the property, gate entrance, or roof door to the equipment room. The limits associated with this notification must be less than the Occupational/Controlled MPE. All sites have standard guidelines posted that must be obeyed and understood by all workers. These guidelines will ensure the area is maintained below Occupational/Controlled MPE. EME awareness training is recommended for all workers.

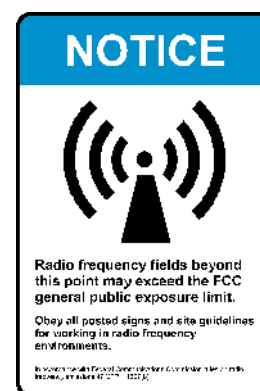

FIGURE A-12 NOTICE SIGN

- Caution

The caution sign identifies RF controlled areas where RF exposure can exceed the Occupational/Controlled MPE. Generic guidelines apply in all situations and will be posted at all sites; however, site specific guidelines may be associated with some areas to ensure work is always performed in compliance with the FCC guidelines. Such site specific guidelines may require reduction of RF power before work begins or the use of RF protective clothing. In all cases workers **shall not** enter and work in these areas without understanding and obeying the necessary procedures. All authorized workers for RF controlled areas must have EME awareness training.

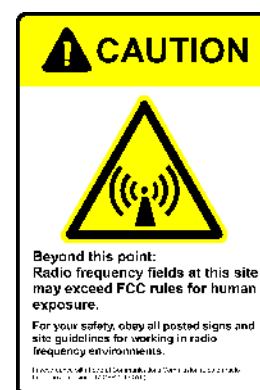

FIGURE A-13 CAUTION SIGN

- Warning

The warning sign denotes the boundary of areas with RF levels substantially above the FCC limits, normally defined as those greater than ten (10) times the Occupational/Controlled MPE.

Telecommunication contractors and employees **shall not** enter these areas unless special procedures are followed. These situations typically are associated with broadcast transmitters operating at high power. If work is required in these areas, the broadcast transmitter must be shut down for the duration of the maintenance. Engineering evaluation must be performed to determine the proper special procedures required before this area can be entered.

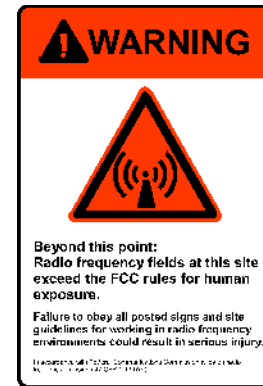

FIGURE A-14 WARNING SIGN

A.6 PERSONAL PROTECTIVE EQUIPMENT (PPE)

A.6.1 PROTECTIVE CLOTHING

There may be situations where field analysis shows areas that are not in compliance with the Occupational/Controlled MPE. After all options are considered and if the situation cannot be controlled with engineering or work practice solutions, implementation of Personal Protective Equipment (PPE) may be the only solution. An example of this type of situation may be a rooftop that has collocated broadcast in the vicinity of a heavily congested antenna field. In certain situations where building architectural concerns are a priority there may be no simple solution available to reduce the fields. The only solution may be the use of RF protective clothing as a means to reduce EME exposure.

RF protective clothing was introduced into the United States several years ago by a German manufacturer (NSP)¹ and sold under the name Naptex™. The suit consists of work coveralls with an integral hood for head protection. The suit is constructed of a polyester yarn, which is wound coaxially around stainless steel fibers. This provides uniform consistency of material and attenuating metal. Tests^{2,3} have shown that the suit can effectively provide between 10 dB and 12 dB of reduction in EME absorption within the body at virtually any frequency over the telecommunications spectrum. This would indicate that use of the suit could compensate for exposure to EME fields as great as 1000% above the FCC Occupational/Controlled MPE values. Additional testing has shown the use of the suit without the hood in fields under 300% of the Occupational/Controlled MPE values at 900 MHz provides compliance with the peak SAR limits of 8 W/kg. The acceptable levels that the hoodless suit can be safely used increase as the frequency is reduced. Contractors **shall** be notified if RF Protective Clothing or the hood is required for compliance.

1. See NSP Website: www.nspworldwide.com
2. Tell, R. A. (1995). *Engineering Services for Measurement and Analysis of Radio frequency (RF) Fields*. Technical report for the Federal Communication Commission, Office of Engineering and Technology, Washington, DC, FCC/OET RTA 95-01 [NTIS order no. PB95-253829].
3. Tell, R. A. (1996). *SAR Evaluation of the Naptex suit for use in VHF and UHF bands*. Presented at the International RF Safety Workshop, Schwangau, Germany, September 25-26.

A.6.2 PERSONAL MONITORS

Work on specific antennas **shall only** be accomplished after the appropriate transmitters have been turned off and locked out. This prevents anyone from accidentally activating the transmitters while others are performing maintenance. However, with the large number of transmitters combined into single antennas it becomes considerably more difficult to confirm that all transmitters are deactivated. The ideal method would be to have a RF light on the top of the antenna. The light would be off to confirm that there was no RF activity. A more practical approach would be to use a personal monitor. A personal monitor is an RF threshold detector that alarms when RF exceeds the threshold of the device, normally 50% Occupational/Controlled MPE. These devices are designed to detect a wide range of frequencies and can be used in most environments. When approaching an antenna that requires maintenance, the monitor **shall** be placed near the antenna for a period of time, about 30 seconds should suffice. If the antenna is still active the monitor will alarm. This will show that there are still transmitters active, or if an alarm does not sound, will confirm that all transmitters were deactivated. This provides a positive confirmation and allows the worker to ensure they are working on inactive antennas.

Some manufacturers of personal monitors propose they can be worn to indicate compliance. This use should be considered carefully because, when the device is used in accordance with its instructions, compliance is only confirmed at the location of the monitor. If, for example, the monitor is worn on the belt of a tower climber, the possibility of entering high fields without the monitor being activated exists. When climbing the head and shoulders can enter high fields without the monitor mounted on the belt alarming. This could provide a false indication of safety.

A.7 EME ACTION THRESHOLDS SUMMARY

As a summary, Figure A-15 describes the actions needed to be taken at the various EME thresholds.



EME Action Thresholds			
Controlled MPE		Post Warning Sign	Only broadcast contractors allowed
1000%			
		EME protective hood High level EME site-specific awareness	Rf Qualified And Trained Worker
300%			
		Post Notice sign Post EME Site Guidelines General EME awareness	General Site Worker
100%			
20%		No procedures required	General Public

FIGURE A-15 EME ACTION THRESHOLDS

SOIL RESISTIVITY MEASUREMENTS

Soil resistivity directly affects the design of a grounding (earthing) electrode system and is the prime factor that determines the resistance to earth of a grounding electrode or grounding electrode system. Therefore, prior to the design and installation of a new grounding electrode system, the proposed location **shall** be tested to determine the soil's resistivity.

(See BS 7430:1998, IEEE STD 81, and MIL-HDBK-419A for more information.)

The terms “grounding” and “earthing” are used synonymously throughout this appendix.

B.1 SOIL RESISTIVITY VARIABILITY AND FACTORS AFFECTING SOIL RESISTIVITY

Soil resistivity varies widely by region due to differences in soil type and changes seasonally due to variations in the soil's electrolyte content and temperature. Therefore, it is recommended that these variations be considered when assessing soil resistivity. To help ensure expected grounding (earthing) electrode system resistance values are achieved throughout the year, worst-case soil resistivity values should be considered when designing a grounding electrode system.

Table B-1 lists ranges of soil resistivity for various types of soil. The values in Table B-1 are the expected values that should be seen when measuring soil resistivity.

NOTE: An ohm-centimeter ($\Omega\text{-cm}$) is the resistance in ohms (Ω) of a one inch cube of soil, measured from opposite sides of the cube.

TABLE B-1 SOIL RESISTIVITY FOR VARIOUS SOIL TYPES

Soil Type	Resistivity ($\Omega\text{-cm}$)		
	Minimum	Average	Maximum
Ashes, brine, or cinders	590	2,370	7,000
Concrete (below ground)		3,000	
Clay, gumbo, loam, or shale	340	4,060	16,300
Clay, gumbo, loam, or shale with varying portions of sand and gravel	1,020	15,800	135,000
Gravel, sand, or stone with little clay or loam	59,000	94,000	458,000

NOTE: “Gumbo” is soil composed of fine-grain clays. When wet, the soil is highly plastic, very sticky, and has a soapy appearance. When dried, it develops large shrinkage cracks.

The resistivity of soil is primarily determined by the soil’s electrolyte contents. Electrolytes consist of moisture, minerals, and dissolved salts. In general, soil resistivity decreases (improves) as electrolytes increase. Figure B-1 shows soil resistivity changes as a function of soil moisture content. The resistivity of the soil decreases rapidly as the moisture content increases from very little moisture to approximately 20 percent moisture.

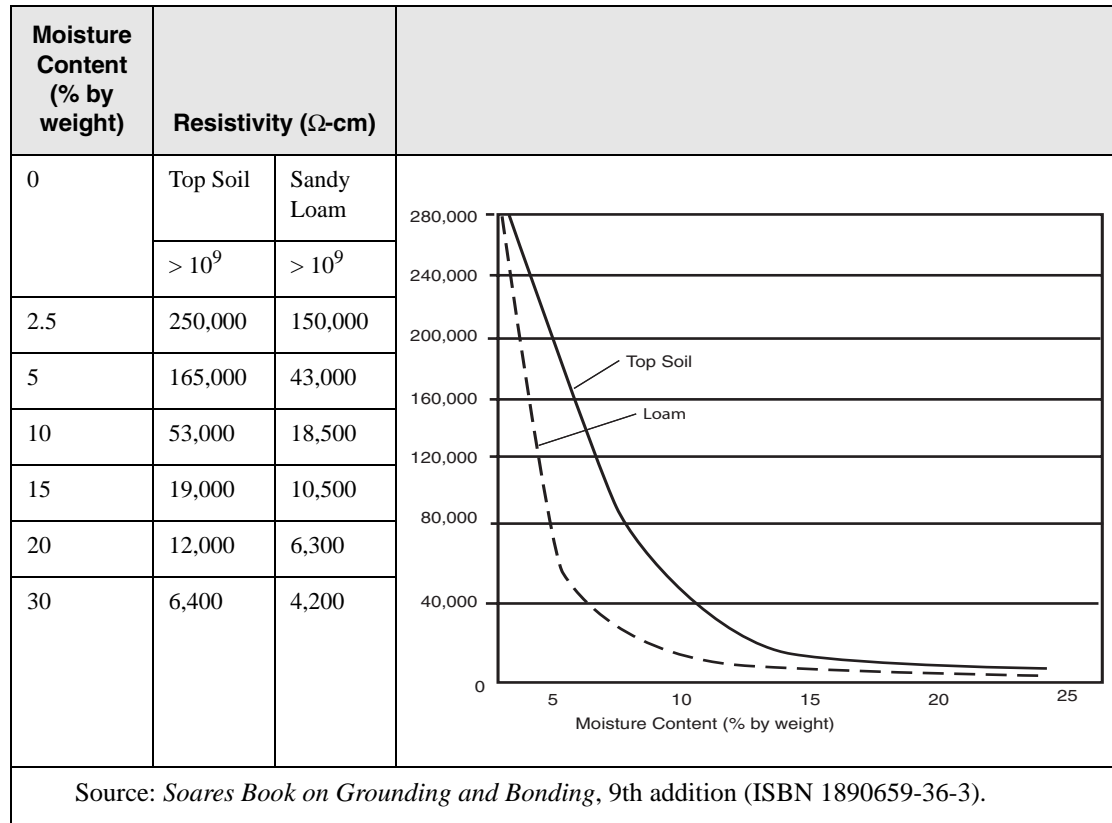

FIGURE B-1 SOIL RESISTIVITY CHANGES AS A FUNCTION OF SOIL MOISTURE

The resistivity of soil is also affected by its temperature. In general, soil resistivity increases as temperature decreases. Figure B-2 shows soil resistivity changes as a function of soil temperature. As shown in the figure, the greatest rate of change in soil resistivity is at the point where moisture in the soil freezes.

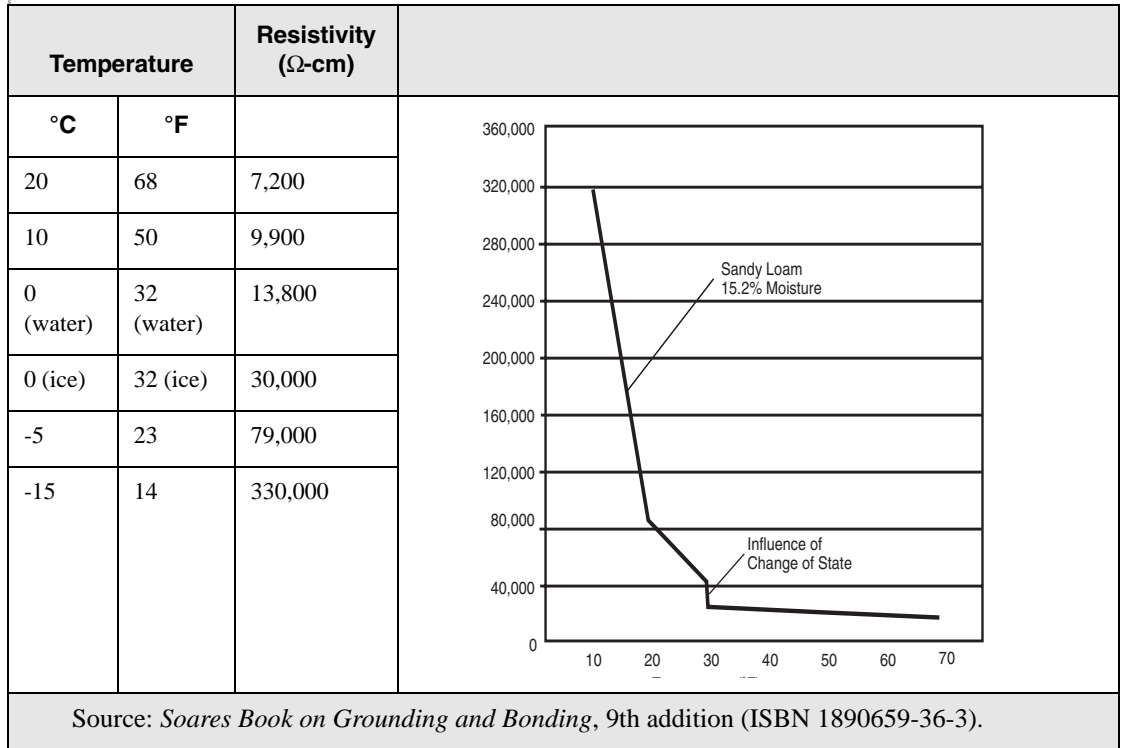
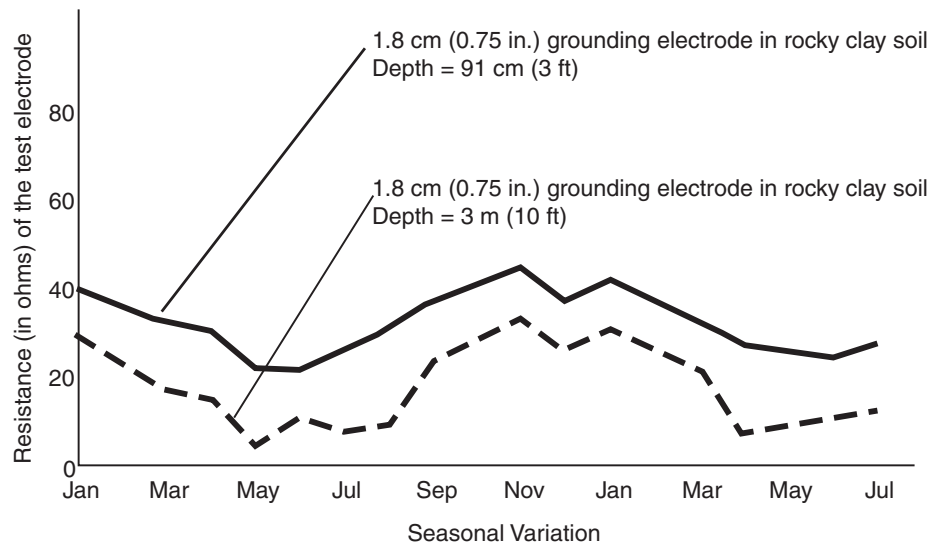

FIGURE B-2 SOIL RESISTIVITY CHANGES AS A FUNCTION OF SOIL TEMPERATURE

Because the resistivity of soil is directly affected by its moisture content and temperature, it is reasonable to conclude that the resistance of any grounding electrode system will vary throughout the different seasons of the year. Figure B-3 shows the seasonal variations of the resistance to earth of a grounding electrode.



Source: Soares Book on Grounding and Bonding, 9th addition (ISBN 1890659-36-3).

FIGURE B-3 SEASONAL VARIATIONS IN GROUNDING ELECTRODE RESISTANCE

Temperature and moisture content both become more stable as distance below the surface of the earth increases. Therefore, in order to be effective throughout the year, a grounding electrode system should be installed as deep as practical. Best results are achieved when ground rods, or other grounding electrodes, reach permanent moisture.

B.2 TESTING METHODS

Two methods of obtaining soil resistivity data are typically used, as follows:

- Four-point (Wenner) method (See BS 7430:1998, IEEE STD 81, and MIL-HDBK-419A for more information.)
- Random core samples

Where possible, the testing should be performed using the four-point testing method; this is the method described in this specification. The area indicating the lowest soil resistivity will be the optimum location for placement of the grounding (earthing) electrode system. A suggested best practice is to perform the test during different seasons of the year whenever possible. The worst-case measured soil resistivity should then be considered in order to design a grounding electrode system that will meet the resistance design goal throughout the year.

Random core sampling should be used only when the four-point test cannot be accomplished, such as in metropolitan areas, areas where buried metallic objects may cause misleading readings, or where surface area is insufficient for proper test performance. Random core sampling **shall** be performed by a geotechnical firm. The random core sample test results can then be used in the section “Interpreting Test Results” on page B-10, or provided to an engineering firm so they can design an appropriate grounding electrode system.

NOTE: The same core samples taken for foundation design can also be used for conducting the random core sample testing.

Core samples should be taken from at least five different test areas as shown in Figure B-5 at depths of 1.52, 3, and 6.1 m (5, 10, and 20 ft.).

B.3 SITE PREPARATION CONSIDERATIONS

NOTE: Do not test an adjacent location if the site location is inaccessible when the testing is scheduled. Reschedule the test so it can be done on the site itself.

Soil resistivity tests must be performed on the actual site, after the following preparation and conditions have been met:

- The site has been leveled to where the foundation will be placed.
- Soil added to the site is satisfactorily compressed before conducting the test, so it will behave as undisturbed soil.
- No precipitation has occurred within 72 hours.

B.3.1 REQUIRED TEST EQUIPMENT AND SUPPLIES

The required test equipment and supplies for performing a soil resistivity test are as follows:

- Ground (Earth) Resistance Tester designed for four-point testing, including all necessary accessories provided by the manufacturer. Accessories should include:

- Operator's manual
- Four test rods (typically supplied with tester)

The test rods should be stainless steel, 610 mm (24 in.) maximum length, 16 mm (0.375 in.) diameter, utilizing a preferred surface penetration of 229 mm (9 in.). Test rods typically come with a four-point testing kit, in lengths from 381 mm (15 in.) to 610 mm (24 in.).

- Four test leads (typically supplied with tester)

The test leads connect the tester to the test rods. If the leads do not use labels or different colors to correlate the test lead connections between the rods and tester terminals, use tags or four different colors of tape to correlate the connections.

IMPORTANT: The connections must be kept in the correct order to maintain symmetry of testing procedures and maintain consistent results.

- Small sledgehammer
- Tape measure
- Safety glasses
- Gloves
- A photocopy of Table B-3 on page B-15. This will be needed to record and keep track of several measurements across the site.

B.3.2 SAFETY



WARNING

Follow the manufacturer's warning and caution information when using the ground resistance tester. Follow furnished instructions when inserting and removing test rods into soil.

- It is required that personnel attempting to measure the resistivity of earth receive prior formal training on the subject and on its associated safety hazards. All applicable laws, rules and codes regulating the work on electrical systems **shall** be complied with at all times.
- Make certain the procedure is fully understood before proceeding with test.

B.3.3 PERFORMING SOIL RESISTIVITY TEST

Perform the test at the location where the site will be built. This procedure describes how to obtain test results for various depths, and how to measure the soil resistivity over the entire site.

IMPORTANT: Buried underground metallic objects such as pipes, cables or tanks can provide an alternate path for test current from a soil resistivity meter, resulting in inaccurate measurements. Therefore, do not test in areas with buried underground metallic objects.

B.3.3.1 MEASURING AT VARIOUS DEPTHS

The soil is typically not homogenous from the surface to the depth being tested and resistivity varies at different depths. Because of this, the four-point test (performed at various depths and at various locations throughout the site) is used to provide a composite result of the soil resistivity.

The testing depth of a soil resistivity test is determined by the spacing between the four test rods which correspondingly connect to tester terminals C1, P1, P2, and C2. The recommended practice is to test the soil at various depths in order to determine the best depth for the grounding (earthing) electrode system. For example, if the test rods are 1.52 m (5 ft.) apart, the measurement will be an average of the soil from the surface down to 1.52 m (5 ft.). As the spacing between the rods is increased, results for correspondingly deeper samples are directly obtained. Table B-2 lists the soil depths measured for different rod spacing distances.

TABLE B-2 SOIL DEPTH MEASURED AS A FUNCTION OF ROD SPACING

Rod Spacing	Soil Depth Measured
1.52 m (5 ft.)	1.52 m (5 ft.)
3 m (10 ft.)	3 m (10 ft.)
6.1 m (20 ft.)	6.1 m (20 ft.)
9.1 m (30 ft.)	9.1 m (30 ft.)
12.2 m (40 ft.)	12.2 m (40 ft.)

B.3.3.2 TESTING THEORY AND ROD ARRANGEMENT

Figure B-4 shows the rod arrangement required for testing. The test requires inserting four test rods into the test area, in a straight line, equally spaced and all at a depth of 229 mm (9 in.). A constant current is injected into the earth from the earth resistance tester through the two outer test rods. The voltage drop resulting from the current flow through the earth is then measured across the inner two test rods. Most testers are designed to provide a direct reading in ohms. This value is then used in one of the following formulas to calculate the soil resistivity (ρ) of the tested area.

$$\rho = 191.5 \times A \times R$$

Where:

ρ = soil resistivity in Ω -cm

A = Distance between test rods (in feet)

R = Resistance obtained from tester (in ohms)

OR

$$\rho = 628 \times A \times R$$

Where:

ρ = soil resistivity in Ω -cm

A = Distance between test rods (in metres)

R = Resistance obtained from tester (in ohms)

The calculated soil resistivity is the average soil resistivity between the soil surface and the depth of the soil equivalent to the rod spacing.

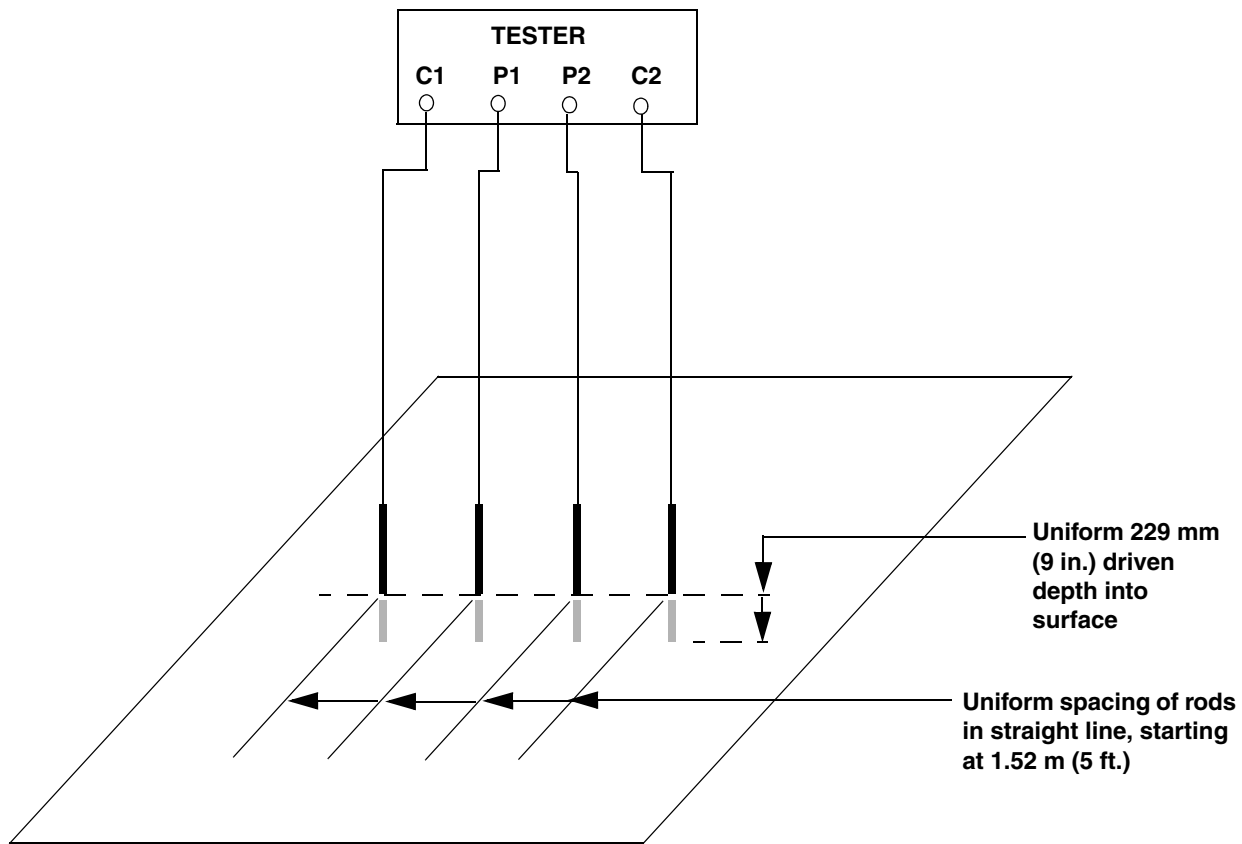

FIGURE B-4 ROD ARRANGEMENT AND SPACING

B.3.3.3 SAMPLES REQUIRED TO DEVELOP ACCURATE SITE RESISTIVITY PROFILE

Because stray currents, buried water pipes, cable sheaths and other factors usually interfere and distort the readings, measurements should be taken along at least three directions. Figure B-5 shows the recommended multiple sampling pattern to develop an accurate profile. Note that the more divergent the samples taken, the more accurate the generated soil model will be.

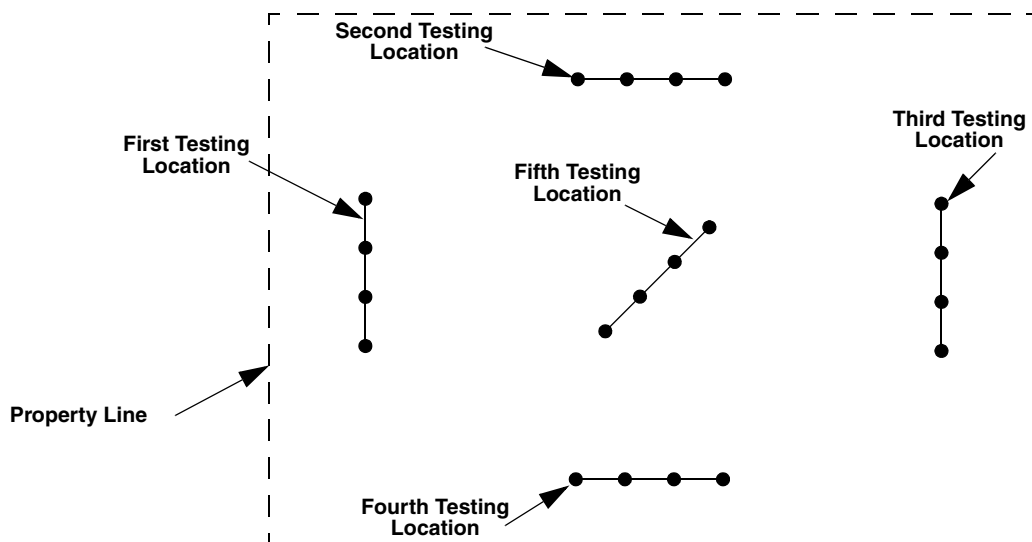

FIGURE B-5 RECOMMENDED MULTIPLE SAMPLING PATTERN ACROSS SITE

B.3.3.4 SOIL RESISTIVITY MEASUREMENT PROCEDURE

Perform the following procedure to obtain soil resistivity readings.



WARNING

Follow the manufacturer's warning and caution information when using the ground resistance tester. Follow furnished instructions when inserting and removing test rods into soil.

1. On tester, verify that the jumper strap between the C1 and P1 terminals is disconnected (if applicable).
2. Starting at the "First Test Location" shown in Figure B-5, drive four test rods into the soil to a depth of 229 mm (9 in.), in a straight line, and spaced 1.52 m (5 ft.) apart (as shown in Figure B-4).

NOTE: The test rods must be connected in the order specified in Step 3. If the test rods are connected incorrectly an inaccurate reading will result.

3. Using test leads, connect the C1, P1, P2 and C2 terminals to their respective test rods, as shown in Figure B-4.
4. Turn the tester on. Press the test button and read the display.

NOTE: If the reading is not stable or displays an error indication, double-check the connection and the meter range setting. If the range is correct, try adjusting the test current. An effective way of decreasing the test rod resistance to ground is by pouring water around the rod. The addition of moisture is insignificant; it will only achieve a better electrical connection and will not influence the overall results.

5. Record the measurement obtained in the appropriate “Meter Readings” space on the photocopy of the “Soil Resistivity Worksheet” on page B-15.
6. Remove the test rods from the soil.
7. In the same location on the site and along the same line as previous test, repeat steps 2 through 6 for remaining spacings listed on the Soil Resistivity Worksheet.
8. Prepare to take measurements for the next test location shown in Figure B-5. Repeat steps 2 through 7 for this location.
9. Repeat steps 2 through 8 for all remaining test locations specified in Figure B-5.
10. On the Soil Resistivity Worksheet copy, calculate and record soil resistivity (ρ) for each of the 25 readings taken in the steps above.

B.3.4 INTERPRETING TEST RESULTS

Depending on the type of grounding electrode system to be installed, proceed to the applicable paragraph below. Test results are interpreted in accordance with MIL-HDBK-419A.

- “Calculating Single Grounding Electrode System Resistance” on page B-10
- “Calculating Multiple Grounding Electrode System Resistance (Electrodes In Straight Line)” on page B-19
- “Multiple Grounding Electrode System Resistance Calculation (Electrodes In Ring Configuration)” on page B-24
- “Calculating Multiple Grounding Electrode System Resistance (Ground Rod Grid Configuration)” on page B-24

NOTE: The interpreted test results are typically conservative because the effects of the horizontal connecting conductors (typically ground rings) are not considered in the following calculations. Consideration of the horizontal connecting conductors requires complex calculations that are beyond the scope of this manual. An engineering firm may be required to perform calculations that consider the effects of the horizontal connecting conductors.

B.3.4.1 CALCULATING SINGLE GROUNDING ELECTRODE SYSTEM RESISTANCE

For a single grounding (earthing) electrode system, the resistance can be easily calculated using a nomograph. Example calculations are shown in Figure B-6 on page B-12 through C-14.

If calculations show excessive resistance for a given electrode depth and diameter, recalculate substituting a larger diameter electrode and/or deeper electrode depth. In this manner, the proper size and depth of grounding electrode for a particular site can be determined. Figure B-6 Sheet 3 shows an example where grounding is improved by substituting a larger-diameter electrode at a deeper depth.

Perform the following procedure to calculate the resistance of the single grounding electrode.

1. Make a photocopy of Figure B-7 on page B-17.
2. On **d** scale of nomograph, plot a point corresponding to the diameter of the grounding electrode to be used.

3. On **L** scale of nomograph, plot a point corresponding to the depth of grounding electrode to be used.
4. Draw a line connecting the **d** and **L** points.
5. Plot ρ value from Soil Resistivity Worksheet on the ρ scale of nomograph.
6. Where the line connecting the **d** and **L** points intersects the **q** line, draw a new line from this point to the point plotted on the ρ scale. Extend this line to the **R** scale. This is the resistance for a single grounding electrode.

B.3.4.2 EXAMPLE WORKSHEET AND NOMOGRAPH

Figure B-6 (sheets 1 through 3) shows example readings and calculations from a completed worksheet and nomograph.

- Sheet 1 shows example readings, as entered from field Ground Resistance Tester measurements and the resulting Soil Resistivity calculations.
- Sheet 2 shows an example of a completed nomograph.
- Sheet 3 shows a second nomograph filled-in with calculations for grounding electrode resistance improvement using a larger-diameter electrode at a deeper depth.

Location "1 of 5" 3 m (10 ft.) spacing is measured on Ground Resistance Tester. In this example, tester reads "2.1 Ω".

"2.1" is written down in "Meter Readings" column for Location "1 of 5" (10 ft. spacing) in Worksheet.

ρ value for Location "1 of 5" 10 ft spacing is calculated using formula on Worksheet.

ρ value of "4021.5" is written down in "Soil Resistivity Calculations" column for Location "1 of 5" (10 ft spacing) in Worksheet.

Location	Spacing (Test Depth)	
	1.52 m (5 ft.)	3 m (10 ft.)
Meter Readings (steps 2 through 5)		
1 of 5	4.2	2.1
2 of 5	4.5	2.5
3 of 5	4.2	2.3

1 of 5	$\rho = 4021.5$	$\rho = \mathbf{4021.5}$
2 of 5	$\rho = 4308.8$	$\rho = 4787.5$
3 of 5	$\rho = 4021.5$	$\rho = 4404.5$

FIGURE B-6 EXAMPLE WORKSHEET AND NOMOGRAPH (SHEET 1 OF 3)

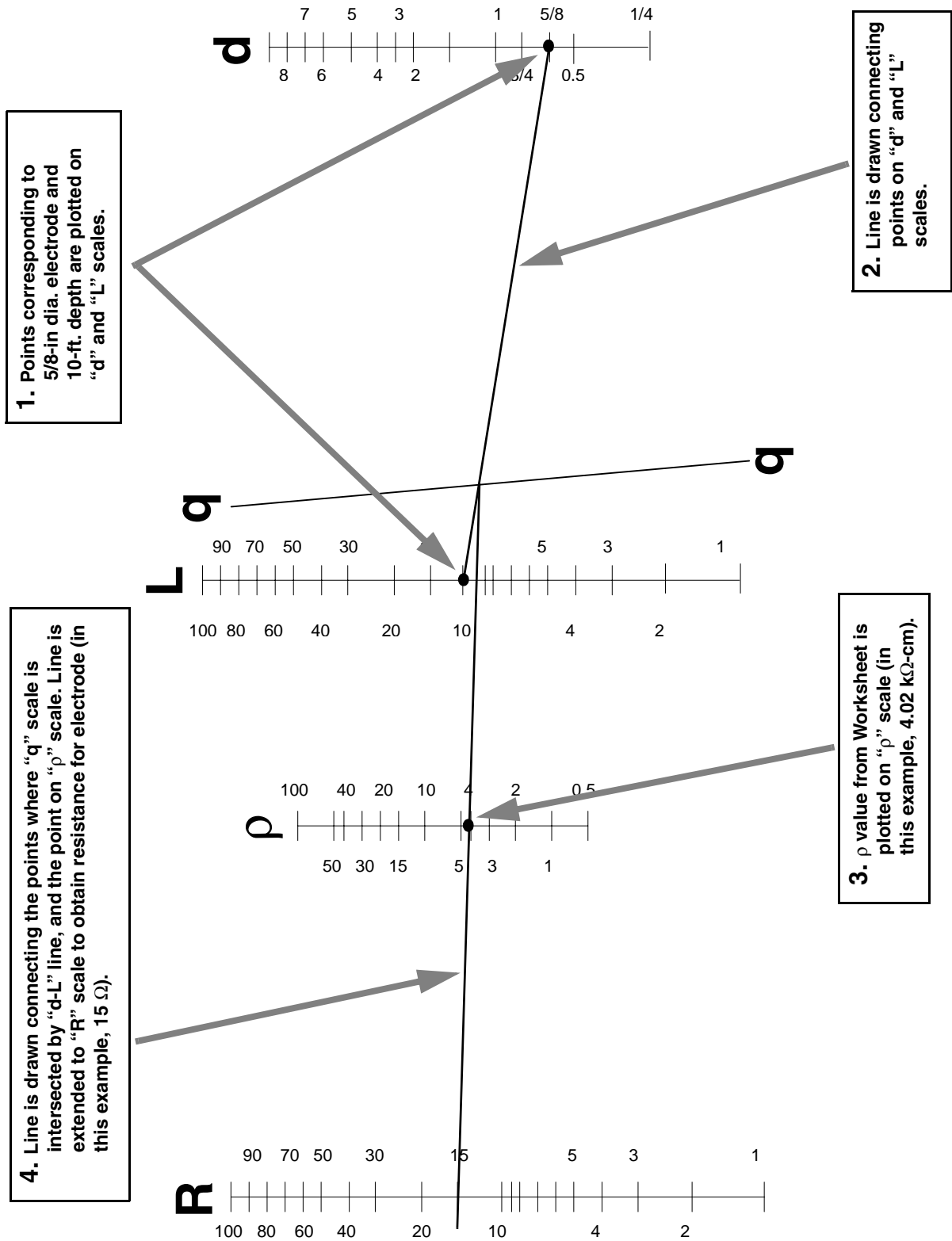

FIGURE B-6 EXAMPLE WORKSHEET AND NOMOGRAPH (SHEET 2 OF 3)

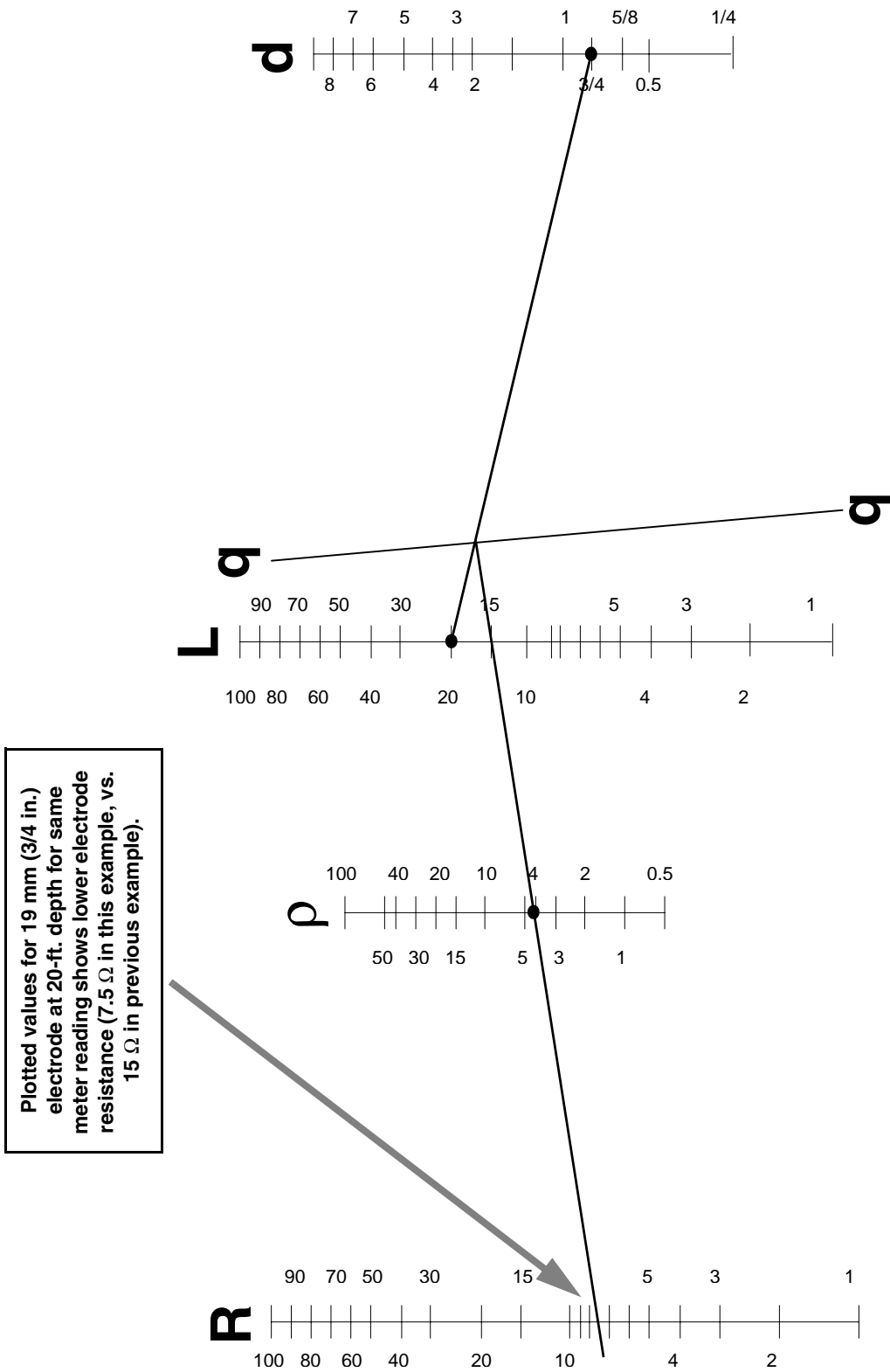

FIGURE B-6 EXAMPLE WORKSHEET AND NOMOGRAPH (SHEET 3 OF 3)

TABLE B-3 SOIL RESISTIVITY WORKSHEET

Location	Spacing (Test Depth)				
	1.52 m(5 ft.)	3 m(10 ft.)	6.1 m(20 ft.)	9.1 m(30 ft.)	12.2 m(40 ft.)
Meter Readings (steps 2 through 5)					
1 of 5					
2 of 5					
3 of 5					
4 of 5					
5 of 5					
Soil Resistivity Calculations (step 10)					
$\rho = 191.5 \times A \times R$ $\rho =$ soil resistivity in Ω -cm A = Distance between test rods (in feet) R = Resistance obtained from tester			OR	$\rho = 628 \times A \times R$ $\rho =$ soil resistivity in Ω -cm A = Distance between test rods (in metres) R = Resistance obtained from tester	
1 of 5	$\rho =$	$\rho =$	$\rho =$	$\rho =$	$\rho =$
2 of 5	$\rho =$	$\rho =$	$\rho =$	$\rho =$	$\rho =$
3 of 5	$\rho =$	$\rho =$	$\rho =$	$\rho =$	$\rho =$
4 of 5	$\rho =$	$\rho =$	$\rho =$	$\rho =$	$\rho =$
5 of 5	$\rho =$	$\rho =$	$\rho =$	$\rho =$	$\rho =$
Test completed by:			Notes:		
Date:					
Client / Project:					
Site Location/ID:					
Ground Resistance Tester Model: _____ S/N: _____ Calibration date: _____					
Soil Description:					
Ambient Conditions Temperature: _____ Present conditions (dry, rain, snow): _____ Date of last precipitation: _____					

THIS PAGE INTENTIONALLY LEFT BLANK.

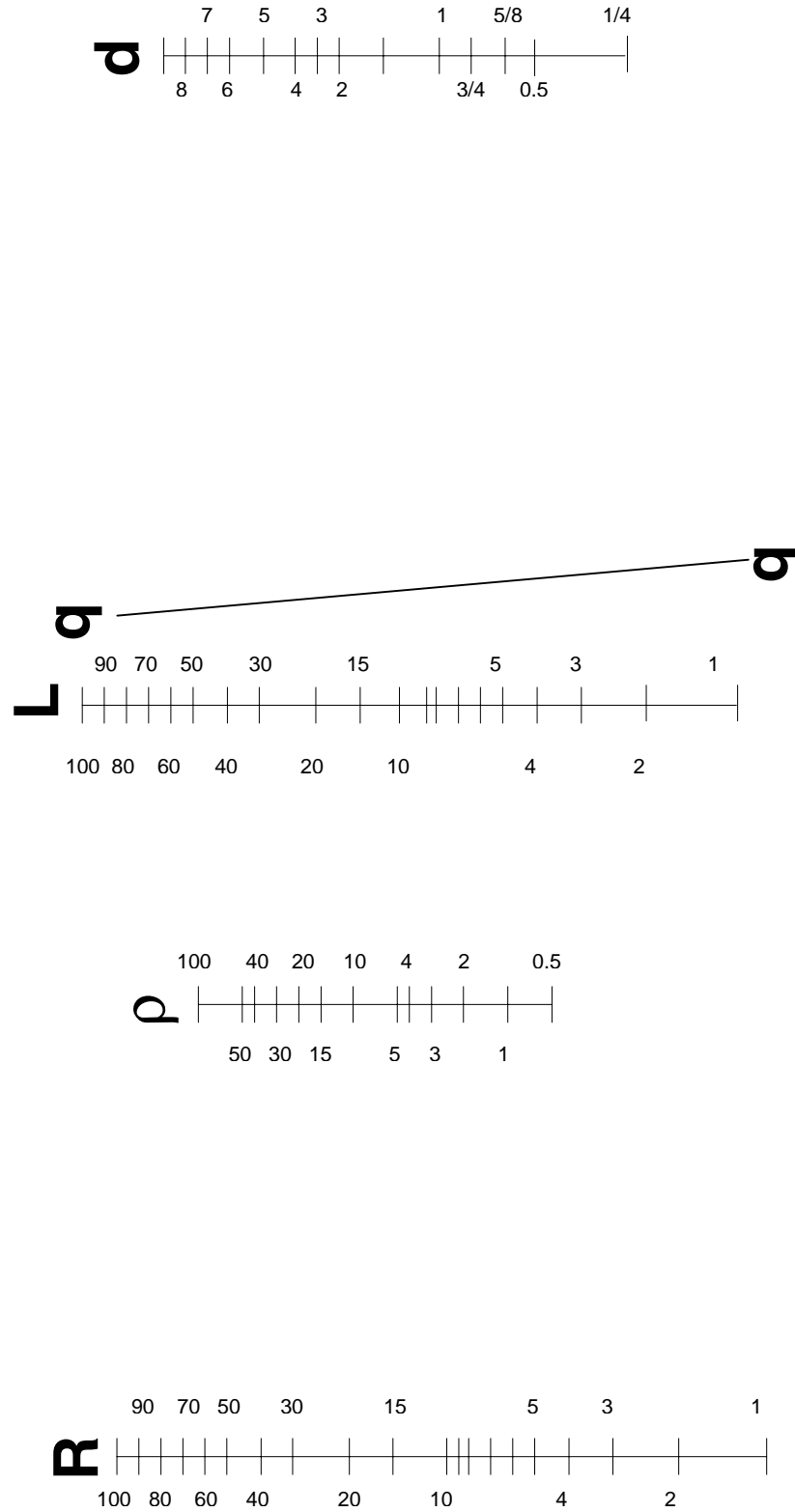

FIGURE B-7 SOIL RESISTIVITY NOMOGRAPH

THIS PAGE INTENTIONALLY LEFT BLANK.

B.3.4.3 CALCULATING MULTIPLE GROUNDING ELECTRODE SYSTEM RESISTANCE (ELECTRODES IN STRAIGHT LINE)

For a multiple grounding (earthing) electrode system with multiple parallel electrodes in a straight line (as shown in Figure B-8), the system resistance can be calculated as described in the following procedure.

1. Perform soil resistivity test as described in “Soil Resistivity Measurement Procedure” on page B-9.
2. Using the worst-case value obtained, calculate the resistance of one ground rod as described in “Calculating Single Grounding Electrode System Resistance” on page B-10. Write down this number.
3. Sketch a proposed layout of the ground rod arrangement using equally spaced rods in a line.

NOTE: The stipulations regarding rod spacing specified in “Ground Rods” on page 4-11 must be observed when planning rod layout.

4. Make a photocopy of Figure B-9 on page B-21.
5. Using the copy of Combined Resistance Graph (Ground Rods Arranged in Line or Ring), calculate the effective resistance of the proposed layout as follows:
 - 5.1 Noting the number of rods to be used, locate this number on the Number of Rods axis of the graph.
 - 5.2 Note the spacing of the rods in the proposed layout in terms of spacing as related to length of rods. In graph, “s=L” is spacing equal to length of rod “s=2L” is spacing equal to twice the length of rod, and so on. Locate the spacing line on graph (s=L, s=2L, s=3L, s=4L) corresponding to proposed spacing.
 - 5.3 At the point on the graph where the Number of Rods line intersects the appropriate spacing line, note the Combined Resistance number at the left.
 - 5.4 Multiply the Combined Resistance number by the resistance of a single ground rod noted in step 2 of this procedure. This is the worst-case resistance of the proposed grounding electrode system.

B.3.4.4 EXAMPLE LAYOUT AND GRAPH

Assuming a layout as shown in Figure B-8 with the following characteristics:

- Eight rods (each of 8-ft. length) are spaced at 4.9 m (16 ft.) points (or “2L” in terms of the graph) along a line.
- Worst-case soil resistivity measurement (step 1 above) is 4021.5 Ω -cm.
- Resistance of single rod tested (step 2 above) is 15 Ω

System resistance is calculated as follows:

1. Using Figure B-14: because eight rods are used, “8” line on **Number of Rods** in graph is selected.
2. Because rod spacing is 4.9 m (16 ft.), or “2L” of rod length, “s=2L” line on graph is selected.
3. At the intersection of the “8” line and the “s=2L” line, draw a horizontal line to the **Combined Resistance** axis at left. Note the point where the horizontal line crosses the **Combined Resistance** axis (in this case, at approximately “18” (or 18% of single rod resistance)).

- Single rod resistance of $15\ \Omega$ is then multiplied by 18% (0.18) to obtain the effective resistance of the system:

$$15\ \Omega \times 0.18 = 2.7\ \Omega$$

In this example, effective overall resistance of the proposed system would be $2.7\ \Omega$.

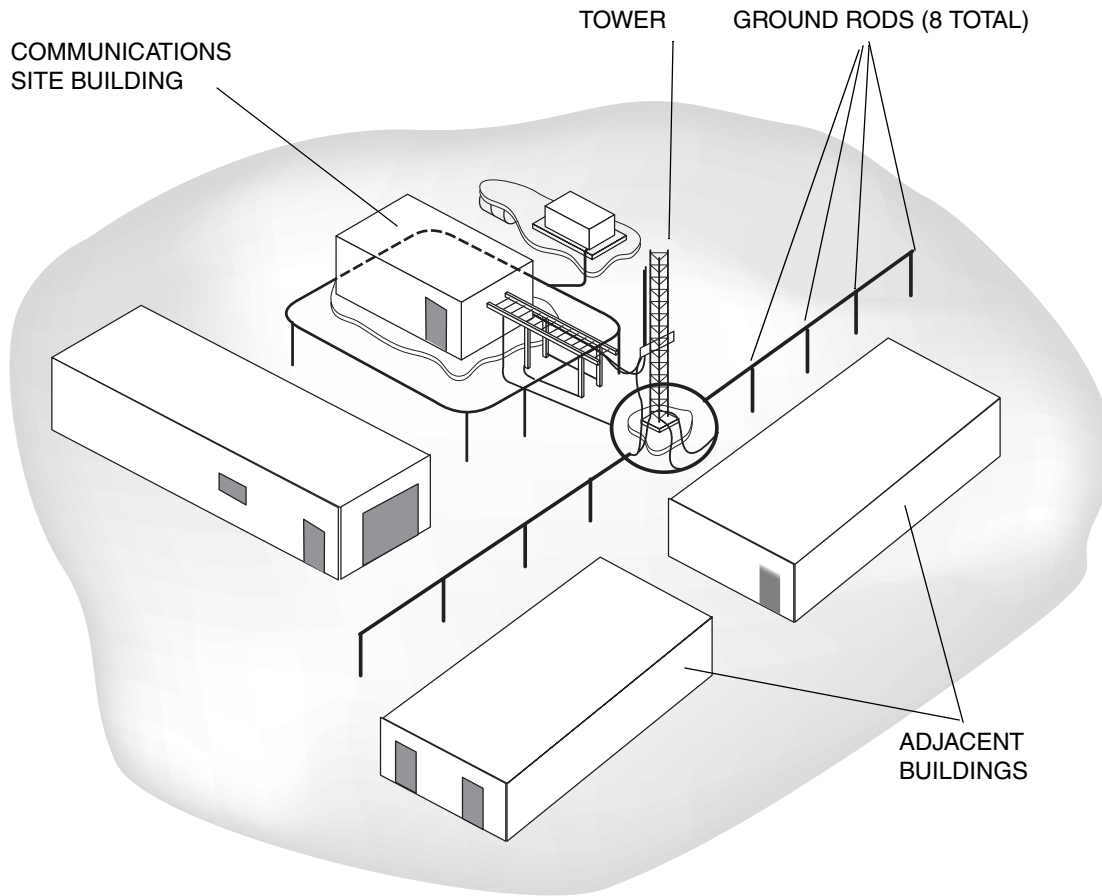

FIGURE B-8 EXAMPLE OF MULTIPLE GROUNDING ELECTRODES IN STRAIGHT LINE

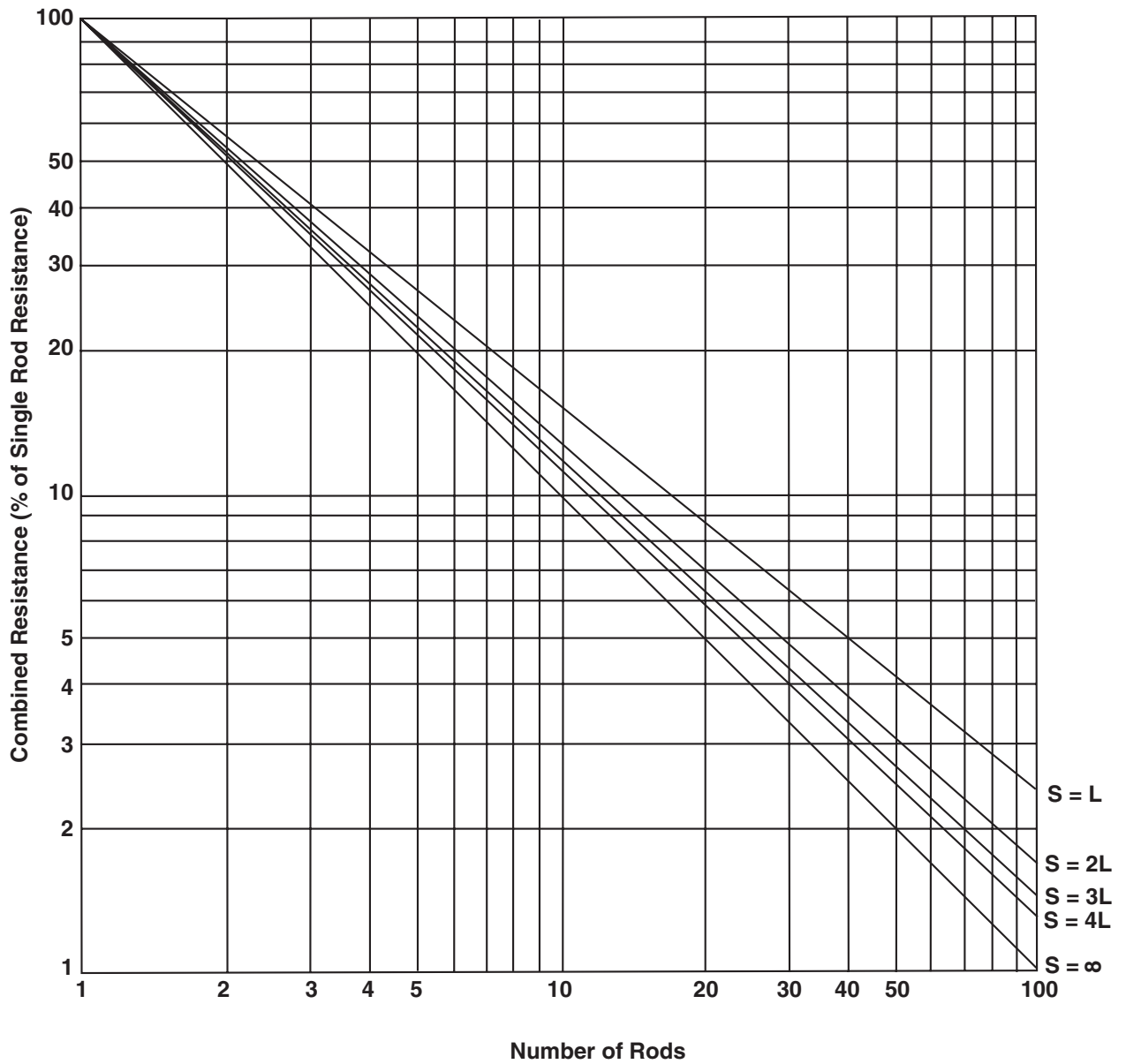

FIGURE B-9 COMBINED RESISTANCE GRAPH (GROUND RODS ARRANGED IN LINE OR RING)

THIS PAGE INTENTIONALLY LEFT BLANK.

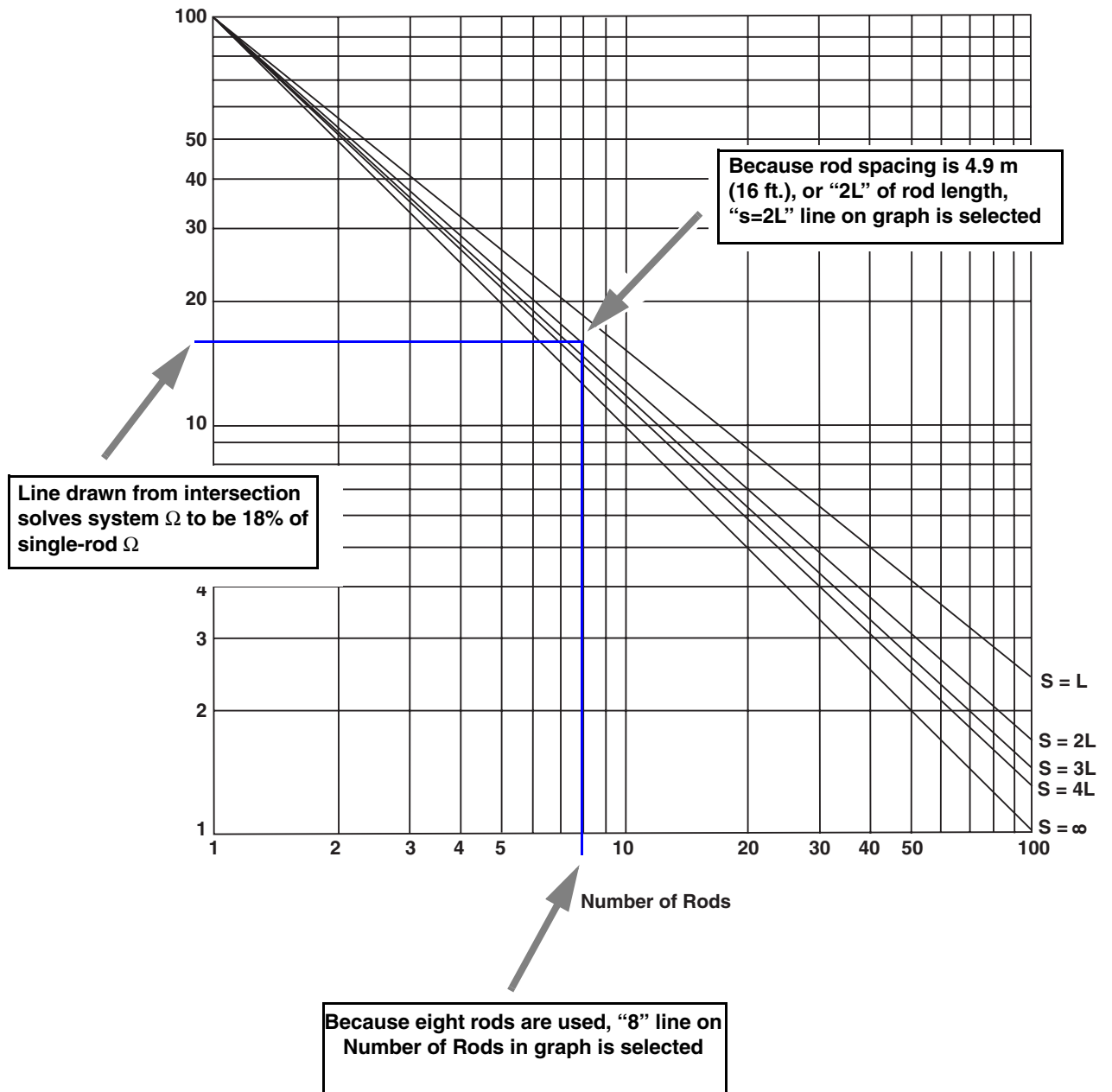

FIGURE B-10 EXAMPLE CALCULATION OF GROUND RODS ARRANGED IN STRAIGHT LINE

B.3.4.5 MULTIPLE GROUNDING ELECTRODE SYSTEM RESISTANCE CALCULATION (ELECTRODES IN RING CONFIGURATION)

For a multiple grounding (earthing) electrode system with multiple electrodes installed in a ring configuration (as shown in Figure B-11), the system resistance is calculated in the same manner as electrodes placed in a straight line.

When planning a ring configuration layout and performing calculations, note the following:

- All rods in the system **shall** maintain equal or greater separation from adjacent rods.
- The distance between rods **shall** be figured in a direct path to adjacent rods, not the circumference distance of the ring.

NOTE: The stipulations regarding rod spacing specified in “External Building and Tower Ground Ring” on page 4-22 must be observed when planning rod layout.

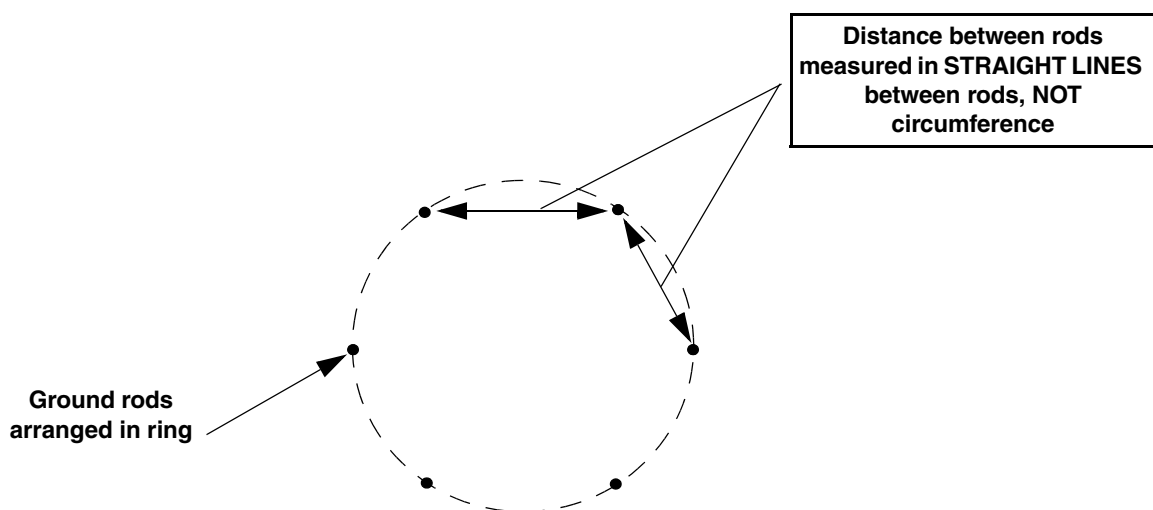

FIGURE B-11 RING CONFIGURATION PLANNING AND RESISTANCE MEASUREMENT CONSIDERATIONS

B.3.4.6 CALCULATING MULTIPLE GROUNDING ELECTRODE SYSTEM RESISTANCE (GROUND ROD GRID CONFIGURATION)

For a multiple grounding (earthing) electrode system consisting of a ground rod grid configuration (as shown in Figure B-12), the system resistance can be calculated as described in the following procedure.

1. Perform soil resistivity test as described in “Soil Resistivity Measurement Procedure” on page B-9.
2. Using the worst-case value obtained, calculate the resistance of one ground rod as described in “Calculating Single Grounding Electrode System Resistance” on page B-10. Write down this number.
3. Sketch a proposed layout of the ground rod arrangement using equally spaced rods across the proposed area.

NOTE: The stipulations regarding rod spacing as specified in “Ground Rods” on page 4-11 must be observed when planning rod layout.

4. Calculate the area of the proposed grid system in square feet.

NOTE: This procedure requires that grid measurements be entered in square feet. If metric measurements have been made, the measurements must be converted to feet. (See Appendix E for conversion formulas.)

5. Make a photocopy of Figure B-13 on page B-27.
6. Using the copy of Combined Resistance Graph (Ground Rods Arranged in Grid), calculate the effective resistance of the proposed layout as follows:
 - 6.1 Noting the number of rods to be used, locate this number on the **Number of Rods** axis of the graph.
 - 6.2 Note the square footage of the proposed rod layout. Locate the curve on the graph most closely corresponding to the proposed square footage.
 - 6.3 At the point on the graph where the **Number of Rods** line intersects the appropriate square footage curve, note the **Resistance Ratio** number at the left.
 - 6.4 Multiply the **Resistance Ratio** number by the resistance of a single ground rod noted in step 2 of this procedure. This is the worst-case resistance of the proposed grounding electrode system.

B.3.4.7 EXAMPLE LAYOUT AND GRAPH

Assuming a layout as shown in Figure B-12 with the following characteristics:

- 16 rods equally spaced across a 30 × 30 ft. grid (900 sq. ft.).
- Worst-case soil resistivity measurement (step 1 above) is 4021.5 Ω-cm.
- Resistance of single rod tested (step 2 above) is 15 Ω

System resistance is calculated as follows:

1. (See Figure B-14 on page B-29.) Because 16 rods are used, the point corresponding to “16” on **Number of Rods** in graph is selected. Draw a line vertically from the “16” point on the graph.
2. Because the grid is 900 sq. ft., a point just below the **1,000** sq. ft. curve on graph is plotted on the line drawn on the graph.
3. At the point plotted in the previous step, (intersection of “900” sq. ft. and “16” rods), draw a horizontal line to the **Resistance Ratio** axis at left. Note the point where the drawn horizontal line crosses **Resistance Ratio** axis (in this case, at approximately “.17”).
4. The single rod resistance of 15 W is then multiplied by 0.17 to obtain the effective resistance of the system:

$$15\Omega \times 0.17 = 2.55 \Omega$$

In this example, the effective overall resistance of the proposed ground system would be 2.55 Ω.

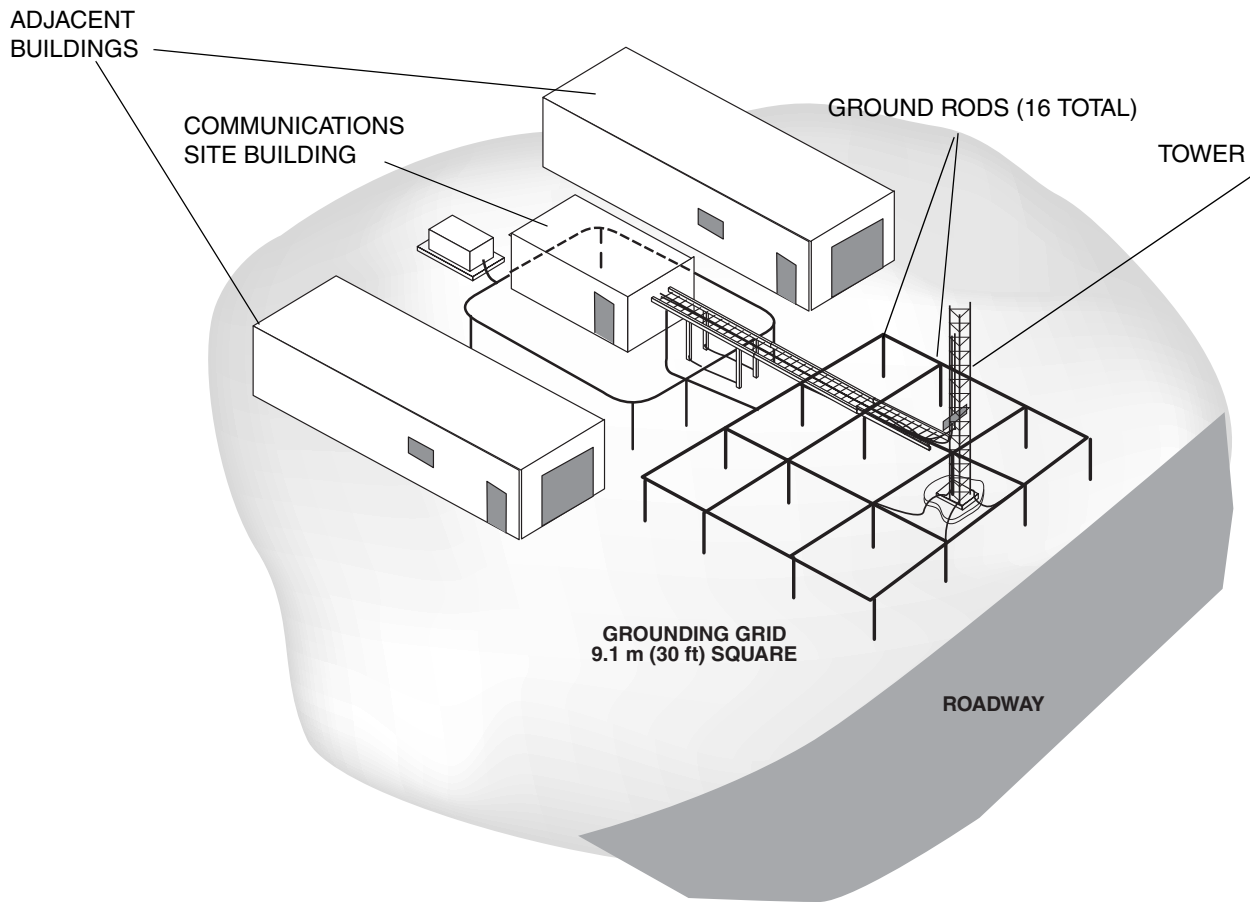

FIGURE B-12 EXAMPLE OF MULTIPLE GROUNDING GROUND ROD GRID CONFIGURATION

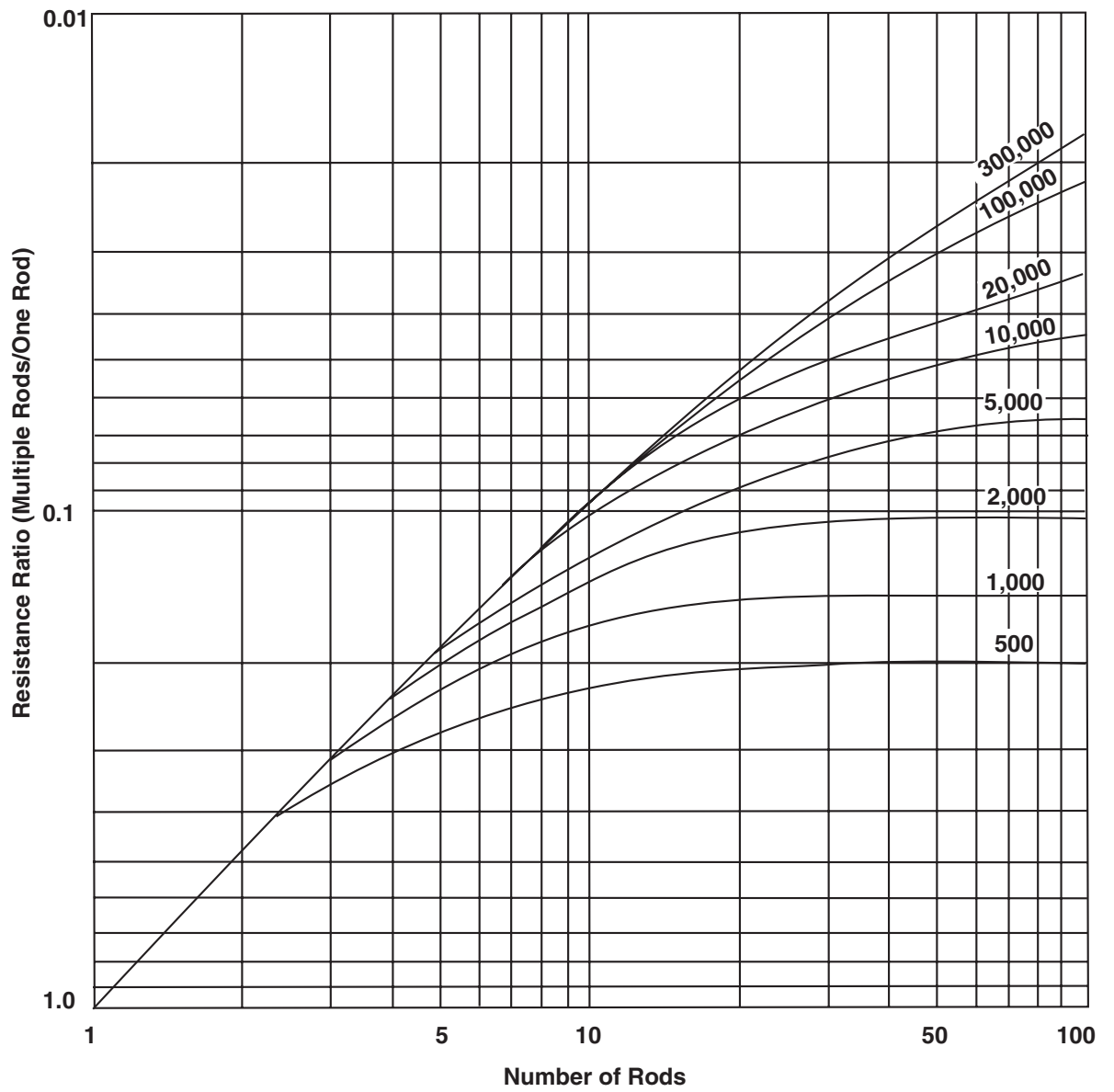

FIGURE B-13 COMBINED RESISTANCE GRAPH (GROUND RODS ARRANGED IN GRID)

THIS PAGE INTENTIONALLY LEFT BLANK.

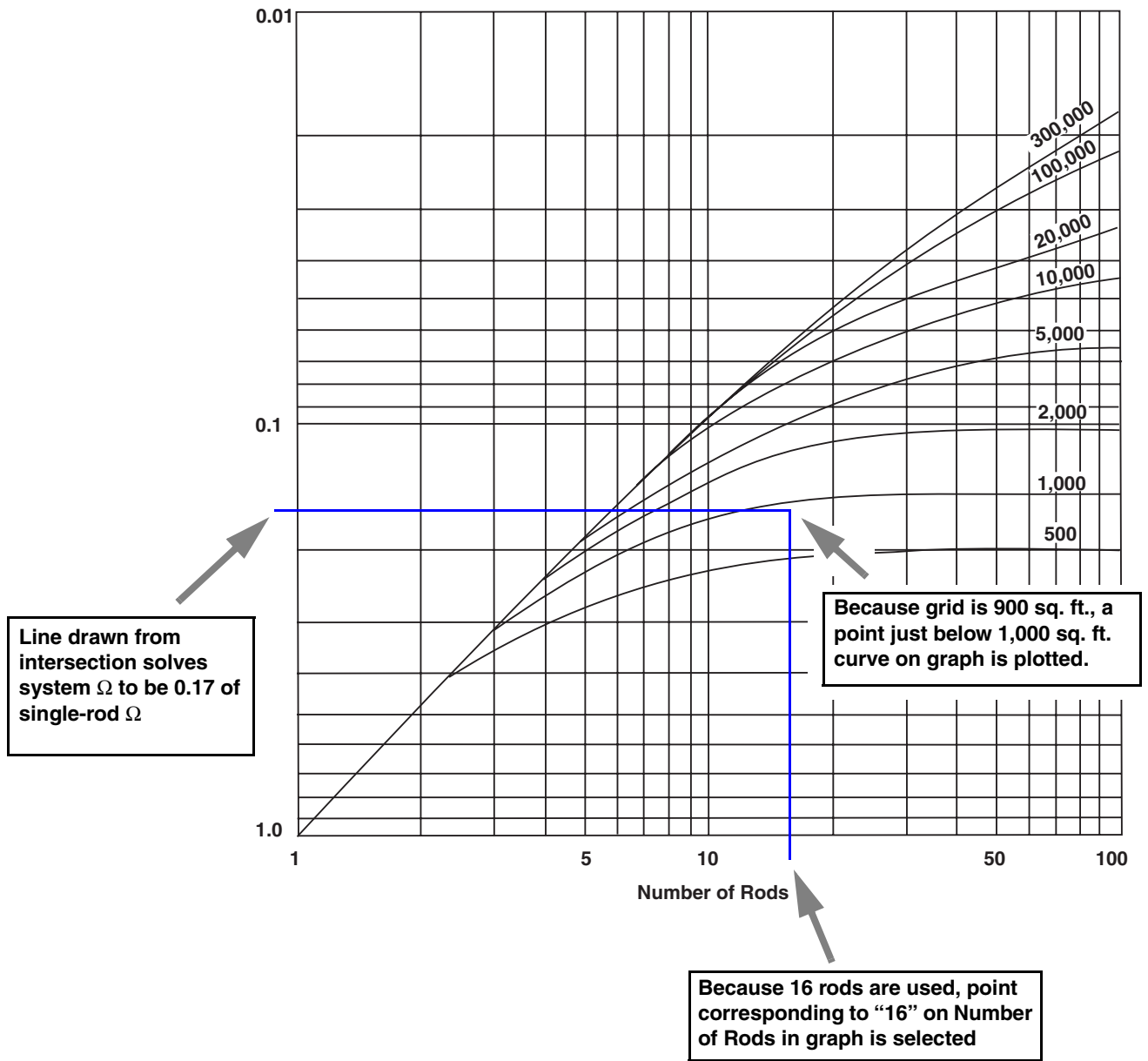

FIGURE B-14 EXAMPLE CALCULATION OF GROUND ROD GRID CONFIGURATION

B.3.4.8 CALCULATING RESISTANCE OF COMPLEX GROUND ROD SYSTEMS

Complex ground rod systems consist of multiple subsystems bonded together to form an overall site ground rod system. Figure B-15 on page B-33 shows a typical complex ground rod system.

Resistance of a complex ground rod system can be calculated by breaking down the system into subsystems. Typically, a ground rod system can be broken down into the following individual subsystems:

- Building ground ring
- Tower ground ring
- Tower radial grounding conductors

For a complex ground rod system consisting of the above subsystems or similar multiple subsystems, the overall system resistance can be approximated as described in the following procedure.

NOTE: Adjacent subsystems should not be laid out closer than the ground rod spacing distance used within a particular subsystem. This is because as subsystems become closer than this distance, the adjacent subsystems begin to “act” as a single subsystem rather than two subsystems.

1. Perform soil resistivity test as described in “Soil Resistivity Measurement Procedure” on page B-9.
2. Using the worst-case value obtained, calculate the resistance of one ground rod as described in “Calculating Single Grounding Electrode System Resistance” on page B-10. Record this number; it is needed for following calculations.
3. Sketch a proposed layout of the ground rod arrangement using equally spaced rods across the proposed area.

NOTE: The stipulations regarding rod spacing as specified in “Ground Rods” on page 4-11 must be observed when planning rod layout.

4. Calculate the resistance of the building ground ring subsystem as described in “Multiple Grounding Electrode System Resistance Calculation (Electrodes In Ring Configuration)” on page B-24. Write down the result.
5. Calculate the resistance of the tower ground ring subsystem as described in “Multiple Grounding Electrode System Resistance Calculation (Electrodes In Ring Configuration)” on page B-24. Write down the result.
6. Calculate the resistance of the tower radial grounding conductor subsystem as follows:
 - 6.1 Calculate and record the resistance of each **individual** tower radial grounding conductor as described in “Calculating Multiple Grounding Electrode System Resistance (Electrodes In Straight Line)” on page B-19.

NOTE: If the radial grounding conductor does not contain ground rods, the resistance to earth of the radial grounding conductor can be calculated as follows:

BURIED
HORIZONTAL
LENGTH OF WIRE
(STRAIGHT)
 $D \ll L$

$$R = \frac{\rho}{\pi L} \left[\ln \left(\frac{2L}{(2aD)^{1/2}} \right) - 1 \right]$$

R = RESISTANCE OF ELECTRODE IN OHMS

ρ = SOIL RESISTIVITY IN METRE-OHMS

L = WIRE LENGTH IN METRES

a = WIRE RADIUS IN METRES

D = WIRE DEPTH IN METRES

- 6.2 Using the results obtained in above step, calculate the **combined (parallel) resistance of the tower ground radials as follows:**

$$R_{\text{total}} = \frac{1}{1/R_{\text{radial 1}} + 1/R_{\text{radial 2}} + \dots + 1/R_{\text{radial n}}}$$

NOTE: The ground rods associated with the tower ground ring are not included in the calculation of the tower radial grounding conductors.

7. Noting the resistances determined for the subsystems, calculate the combined (parallel) resistance of **all of the subsystems** as follows:
- subsystem 1 (building ground ring subsystem; step 4)
 - subsystem 2 (tower ground ring subsystem; step 5)
 - subsystem 3 (tower ground radial subsystem; step 6)

$$R_{\text{total}} = \frac{1}{1/R_{\text{subsystem 1}} + 1/R_{\text{subsystem 2}} + 1/R_{\text{subsystem 3}}}$$

NOTE: Total resistance does not include incidental influence from site fencing, buried fuel tanks, or other objects not included in these calculations. More complex grounding systems, or highly accurate results where other objects exist, will require the assistance of an appropriate engineering consultant.

B.3.4.9 EXAMPLE CALCULATION OF COMPLEX SYSTEM

Assuming a layout as shown in Figure B-15 with the following characteristics:

- Worst-case soil resistivity measurement (step 1 above) is 4021.5 Ω -cm.
- Building ground ring (step 4 above) using four rods, each with a resistance of 15 Ω . Building ground ring subsystem calculates to approximately 4.35 Ω .
- Tower ground ring (step 5 above) using three rods, each with a resistance of 15 Ω . Tower ground ring subsystem calculates to approximately 5.55 Ω .
- Tower radial grounding conductor subsystem (step 6 above) as shown in Figure B-15. Total resistance of this subsystem is as follows:
 - Radial "A" has three ground rods. Resistance of this radial calculates to approximately 5.55 Ω .
 - Radial "B" has two ground rods. Resistance of this radial calculates to approximately 8.1 Ω .
 - Radial "C" has two ground rods. Resistance of this radial calculates to approximately 8.1 Ω .

Tower ground radial calculates to 2.34 Ω , as shown below using the formula provided in step 6:

$$R_{\text{tower radial}} = 2.34 \Omega = \frac{1}{1/(5.55\Omega) + 1/(8.1\Omega) + 1/(8.1\Omega)}$$

Overall system resistance is calculated as follows:

1. The individual resistances of the three subsystems are noted:
 - **Building ground ring = 4.35 Ω**
 - **Tower ground ring subsystem = 5.55 Ω**
 - **Tower ground radial = 2.34 Ω**
2. The combined (parallel) resistance of all of the subsystems is now calculated as follows:

$$R_{\text{total}} = 1.19 \Omega = \frac{1}{1/(4.35\Omega) + 1/(5.55\Omega) + 1/(2.34\Omega)}$$

In this example, the calculated effective overall resistance of the proposed system would be **1.19 Ω** .

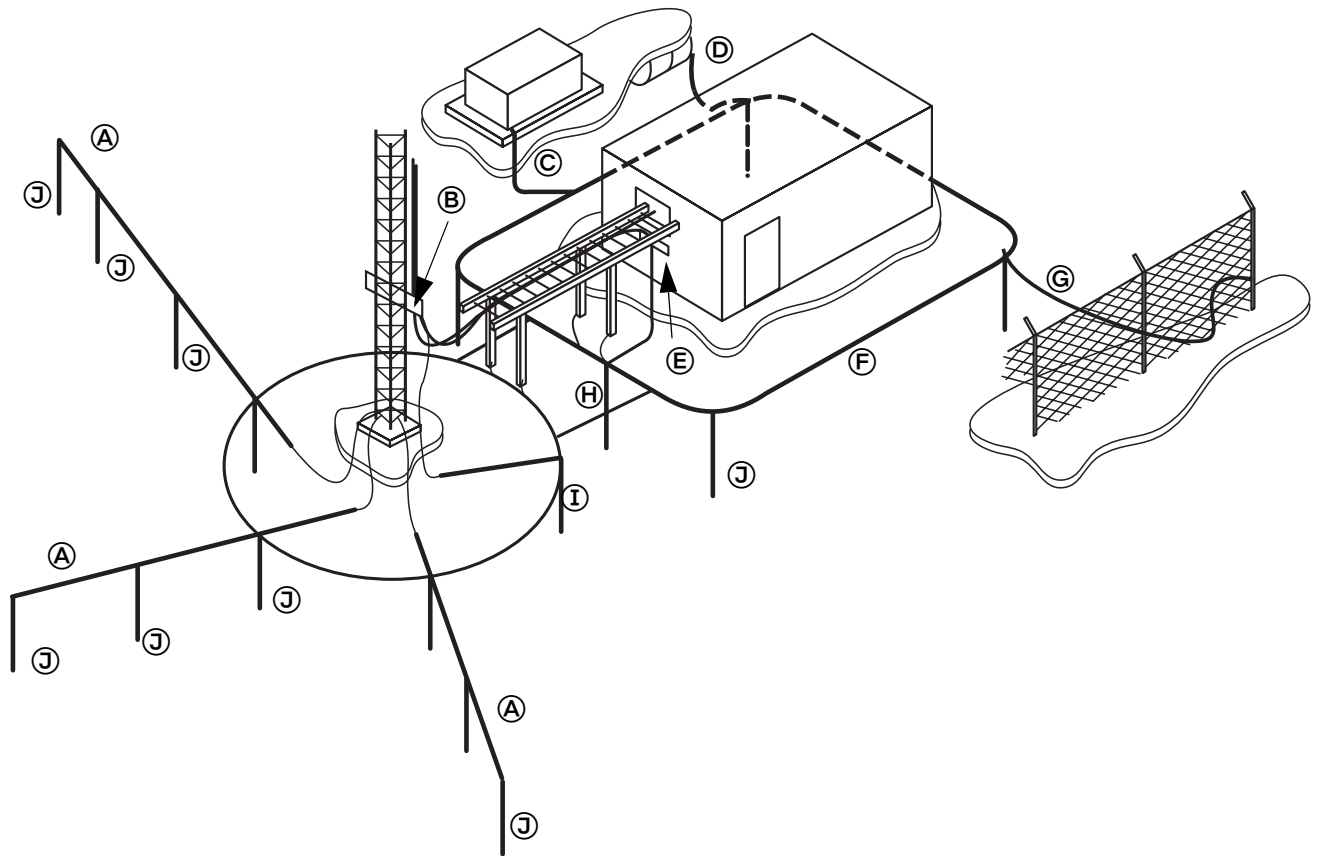

- A: Grounding Radials**
- B. Tower Ground Bus Bar and Down Conductor**
- C. Generator Grounding Conductor**
- D. Buried Fuel Tank Grounding Conductor**
- E. External Ground Bus Bar**
- F. Shelter Ground Ring**
- G. Fence Grounding Conductor**
- H. Ground Ring Bonding Conductors (2 minimum)**
- I. Tower Ground Ring**
- J. Earthing Electrodes (Ground Rods)**

FIGURE B-15 TYPICAL COMPLEX GROUNDING ELECTRODE SYSTEM

THIS PAGE INTENTIONALLY LEFT BLANK.

PROTECTING AGAINST ELECTROSTATIC DISCHARGE IN EQUIPMENT ROOMS AND DISPATCH CENTERS

C.1 BACKGROUND INFORMATION

Static electricity is defined as an electrical charge that is caused by an imbalance of electrons on the surface of a material. This imbalance of electrons produces an electric field that can influence other objects at a distance. Electrostatic Discharge (ESD) is defined as the transfer of electrical charge between bodies at different electrical potentials.

ESD can severely affect the performance and reliability of electronic equipment. ESD failures may occur at a site and not immediately be detected because voltage levels that can cause component failure are below the perception threshold of the individual. (IEEE STD 1100-1999, section 6.4.3.3)

Electrostatic charges are built up on the human body by triboelectric charging. Triboelectric charging takes place when two materials come in contact and are separated and a transfer of positive or negative ions takes place. Just by walking across an unprotected floor when the humidity level is low, a person can create a triboelectric charge buildup in the range of 25,000 volts and up. Cathode-ray tube video terminals can also generate intense electric fields that can transfer high amounts of electrostatic charges on the human body. Normally, discharges from the hand are usually imperceptible below potentials of 3000 volts; for sensitive areas such as the face, the threshold of perception may be 500 volts or lower (ANSI T1.321-R2000, section 4).

Electrostatic buildup and discharge in a dispatch room can be very annoying to the operator especially when the high voltage energy discharges through the operator's headset ear piece. The high voltage discharge can not only cause annoyance and pain due to the high voltage heat transfer, it can also cause data and audio signal corruption as well as damage or destroy equipment.

C.2 EQUIPMENT HANDLING AND STORAGE

To reduce ESD damage to electronic equipment, wrist straps connected to ground should be worn when handling static sensitive devices. Static-dissipative work surfaces and grounded dissipative (or conductive) floor surfaces should be used in equipment rooms. Storage areas should contain grounded cabinets on grounded permanently static-dissipative shelves. Ground points for wrist straps should be provided at strategic locations near equipment sensitive to electrostatic discharge. (ANSI T1.334-2002, section 12)

C.3 MEASURES FOR CONTROLLING ELECTROSTATIC DISCHARGE

Depending on the environment and mobility requirements of personnel, there are several ways to address ESD concerns. The least costly ways are more restrictive to personnel mobility and require more focus on properly established and institutionalized operating procedures (such as wrist-straps); these means will not help to eliminate the occurrence of ESD, but will help to dissipate the electrostatic charge from the person's body and keep it from entering the communications system equipment.

There are many strategies for minimizing ESD events. The following sections provide some options, but are not all-inclusive. As a rule, not all of these techniques will be either necessary or desirable to establish an ESD protected area. The appropriate ESD protection strategy should be based on the particular application and the advantages and disadvantages of each ESD protective method. (ANSI T1.321-R2000, section 4)

C.3.1 WRIST-STRAPS

Personnel can be equipped with ESD-rated wrist-straps. The person connects the wrist-strap to an effectively grounded jack before connecting to the headset jack or touching equipment or grounded objects. The wrist-strap **shall** provide dissipative resistance values and other safety measures as described within ANSI/ESD S1.1-1998 or later.

C.3.2 RELATIVE HUMIDITY CONTROL

Control of the relative humidity can be an effective means for helping control ESD occurrences because higher relative humidity aids in static dissipation and is associated with lowered triboelectric charging. Rooms containing network operator positions (dispatch centers) should maintain a relative humidity within the range of 40 to 55 percent (ANSI T1.321-R2000). When the humidity drops below 40 percent, ESD events are more likely to occur. If humidity is kept above 55 percent, electrolytic corrosion may affect equipment performance and microbial contamination may occur (ANSI T1.321-R2000).

Table C-1 lists typical voltage levels at different relative humidity levels. The table and additional information on ESD control can be found on the Electrostatic Discharge Association web site <http://www.esda.org>.

TABLE C-1 EXAMPLES OF STATIC GENERATION TYPICAL VOLTAGE LEVELS

Means of Generation	10-25% RH	65-90% RH
Walking across carpet	35,000 Volts	1,500 Volts
Walking across vinyl tile	12,000 Volts	250 Volts
Worker at bench	6,000 Volts	100 Volts
Poly bag picked up from bench	20,000 Volts	1,200 Volts
Chair with urethane foam	18,000 Volts	1,500 Volts

C.3.3 FLOORING

Carpeting or floor tiles within an equipment room or dispatch center, including raised flooring, should have a resistance to ground measurement of between 10^6 and 10^9 ohms when measured using the test method of ANSI/ESD STM7.1-2001 or later. Existing flooring that does not meet this requirement should be treated with a topical solution such as an antistatic floor wax or spray solution. The effectiveness of antistatic solutions is temporary and varies with floor material and relative humidity. Flooring resistance should be monitored every two weeks minimum to verify conformance to the above requirements. (ANSI T1.321-R2000, section 4.2 and ANSI/ESD STM7.1-2001)

When ESD protective flooring is used, the following should be observed:

- ESD protective flooring should be installed per the manufacturer's recommendations.
- ESD protective flooring and floor coverings should be installed, grounded, and tested by trained installers.
- Personnel entering the equipment room or dispatch area should wear ESD dissipative footwear or dissipative foot straps. The footwear should provide dissipative resistance values of less than 35×10^6 ohms as measured according to the measuring requirements within ANSI/ESD STM97.1-1999 or later. The footwear should also provide dissipative resistance values of less than 1.0×10^9 ohms as measured in accordance with the measuring requirements of ANSI/ESD STM9.1-2001 or later.

When ESD protective flooring is not installed at a dispatch position or equipment room, an ESD protective floor mat should be installed at the work areas. When ESD protective floor mats are installed, the following should be observed:

- The floor mat should provide dissipative resistance values between 10^6 and 10^9 ohms when measured using the test method of ANSI/ESD STM7.1-2001 or later.
- The floor mat should be effectively bonded to the common grounding point.
- Personnel should wear ESD dissipative footwear or dissipative foot straps. The footwear should provide dissipative resistance values of less than 35×10^6 ohms as measured according to the measuring requirements within ANSI/ESD STM97.1-1999 or later. The footwear should also provide dissipative resistance values of less than 1.0×10^9 ohms as measured in accordance with the measuring requirements of ANSI/ESD STM9.1-2001 or later.
- Personnel should stand on the floor mat before connecting to the headset jack or touching equipment or grounded objects.

C.3.4 CHAIRS

Chairs used in dispatch centers should be ESD protective and have a resistance to ground measurement of between 10^5 and 10^9 ohms when measured using the test method of ANSI/ESD STM12.1-1997 or later. Such chairs operate in conjunction with ESD protective flooring (see previous paragraph). (ANSI T1.321-R2000, section 4.3 and ANSI/ESD STM12.1-1997)

ESD protective chairs should incorporate a continuous path between all chair elements and the ground point. The ground point of a static dissipative chair should be the static dissipative chain or the conductive casters that provide electrical continuity to the ESD flooring material. (See FAA-STD-019d-2002 for additional information.)

NOTE: Non-dissipative floor mats or chair mats should never be placed over dissipative flooring material. If floor mats are used, they **shall** be of a dissipative material with a grounding conductor that is effectively bonded to the common grounding point or the multi-point grounding system.

C.3.5 DISPATCH POSITION DESKTOPS

Work surfaces on the operator position desktops that may be touched by the operator should have a resistance to ground measurement of between 10^6 and 10^9 ohms when measured using the test method of ANSI/ESD -S4.1-1997 or later. If an existing desktop does not meet this requirement, an ESD protective mat can be installed under and around the keyboard and mouse. To be effective, the ESD protective desktop or ESD protective mat must be bonded to the operator position common grounding point. (See ANSI T1.321-R2000, section 4.4 and ANSI/ESD S4.1-1997 for additional information.)

To help avoid ESD, the operator must touch the ESD protective desktop or ESD protective mat before connecting to the headset jack or touching equipment or grounded objects.

C.3.6 VIDEO DISPLAY TERMINALS

If a cathode-ray tube (CRT) monitor is used, installation of an electrostatic shield such as a properly grounded bezel or a conductive anti-glare shield that is properly bonded back to the common grounding point will be of some benefit (ANSI T1.321-R2000). Another option is installing LCD displays, which do not generate high electrostatic fields.

C.3.7 EQUIPMENT BONDING, GROUNDING, AND SURGE PROTECTION

All equipment, including headset jacks, located in an ESD-susceptible area, **shall** be properly bonded and grounded in accordance with the requirements of “Grounding (Earthing) for Dispatch Centers and Network Operator Positions,” on page 5-62.

Surge suppression should be provided in accordance with “Surge Protection Considerations for Dispatch Centers and Operator Positions,” on page 7-43.

C.4 ESD CONTROL PROGRAM

After preventive measures have been implemented to help eliminate or dissipate electrostatic charges, an effective ESD control program should be implemented to maintain the environment. For additional information on how to establish an effective ESD control program, see Part Two - Principles of ESD Control at the Electrostatic Discharge Association web site

(<http://www.esda.org/aboutesd.html>).

GROUNDING (EARTHING) ELECTRODE SYSTEM TESTING/VERIFICATION

Procedures in this Appendix **shall not** be performed by untrained or unqualified personnel, nor are any procedures herein intended to replace proper training. It is required that personnel attempting to measure the resistance of a grounding (earthing) electrode system receive prior formal training on the subject and on its associated safety hazards. All applicable laws, rules and codes regulating the work on electrical systems **shall** be complied with at all times.

This appendix provides procedures for performing resistance testing of the site grounding electrode system. The resistance of a grounding electrode system **shall** be measured after its installation and before it is bonded to the power company neutral wire or any other utility, such as the telephone ground or metallic pipes.

Periodic testing should be performed on the site annually when the site grounding electrode system can be safely disconnected from the power company neutral wire (if using the fall-of-potential test). Suggested best practice is to perform the test at three-month intervals for the first year and every 21 months thereafter (MIL-HDBK-419A).

NOTE: Grounding electrode system testing should be performed anytime the site is suspected to have taken a direct lightning strike.

NOTE: Throughout this appendix the terms *grounding* and *earthing* are used synonymously.



WARNING

It should be strongly impressed on all test personnel that a lethal potential can exist between the station ground and a remote ground if a power-system fault involving the station ground occurs while ground tests are being made. Because one of the objectives of tests on a station-ground system is to establish the location of remote earth for both current and potential electrodes, the leads to these electrodes must be treated as though a possible potential could exist between test leads and any point on the station ground grid. Under no circumstances should the two hands or other parts of the body be allowed to complete the circuit between points of possible high-potential difference. (See IEEE STD 81-1983, section 5.1.)



WARNING

To help protect against shock hazard, wearing insulated electrician's gloves is recommended while performing grounding electrode system testing.

D.1 OVERVIEW

Testing can be performed using one of the following three methods described in this chapter:

- **Fall-of-Potential Testing**

This method is the most widely accepted. However, performing the test may require access to areas that may be beyond the site property lines. When testing a grounding electrode system consisting of a multi-bonded/multi-grounding electrode system, the distance required for testing is directly related to the effective diagonal distance of the buried grounding electrode system.
- **Clamp-on ohmmeter**

This method should be used when access to necessary space needed for the fall-of-potential test is not available. However, the clamp-on ohmmeter test can only be performed after the AC utilities have been connected to the site and various feed conductors are accessible.
- **Combined Soil Resistivity Testing with Clamp-on Ohmmeter Testing**

This method should only be used in special cases where fall-of-potential testing or clamp-on ohmmeter testing cannot directly provide a suitable evaluation. The data obtained from soil resistivity testing and clamp-on ohmmeter testing is then used by an engineering firm specializing in grounding electrode system design to make determinations regarding the grounding electrode system.

D.2 PREREQUISITES FOR TESTING

The following conditions must be met in order to perform grounding electrode system testing:

- Fall-of-Potential testing is possible only if the following conditions can be met:
 - Sufficient land area must be available to perform a fall-of-potential test. The reference probe may likely need to be inserted into soil that is beyond the site fence or property line. Testing using a clamp-on ohmmeter may be an option in these cases.
 - The grounding electrode system must be able to be isolated from the power company grounded conductor (may be a neutral wire) and other utility grounds.
- Clamp-on ohmmeter testing is possible only if the following conditions can be met:
 - The site must be supplied with commercial power. Sites supplied only by a generator or other non-commercial power may not be suitable for clamp-on ohmmeter testing.
 - A neutral wire must be present as part of the power company service.
 - A neutral wire must be part of an extensive power company grounding system. In systems such as 3-phase delta service, the neutral wire may not be part of the extensive power company grounding system.
 - The grounding electrode system must be connected to the power company grounded conductor (may be a neutral wire).
 - For sites using a multi-bonded/multi-grounding electrode system (commonly used at communications sites), a point on the neutral wire before its first bond to the site must be available for using the clamp-on ohmmeter.
 - For a single grounding electrode system, the grounding electrode conductor must be accessible to the clamp-on ohmmeter at a point between the grounding electrode and any other connection (such as the telephone company ground or a metallic pipe).

- Combined soil resistivity/clamp-on ohmmeter testing is possible only if the following conditions can be met:
 - The system must be such that gathering of individual grounding electrode system component values with a clamp-on-ohmmeter can be available for use by an engineering firm.
 - A soil resistivity profile for the site has been performed and is available for use by an engineering firm.

If these conditions cannot be met, an added supplemental grounding electrode system can be installed. This supplemental grounding electrode system can be installed and tested prior to its connection to the existing system. This supplemental system should be installed in such a manner as to allow an easy disconnect point for future testing.

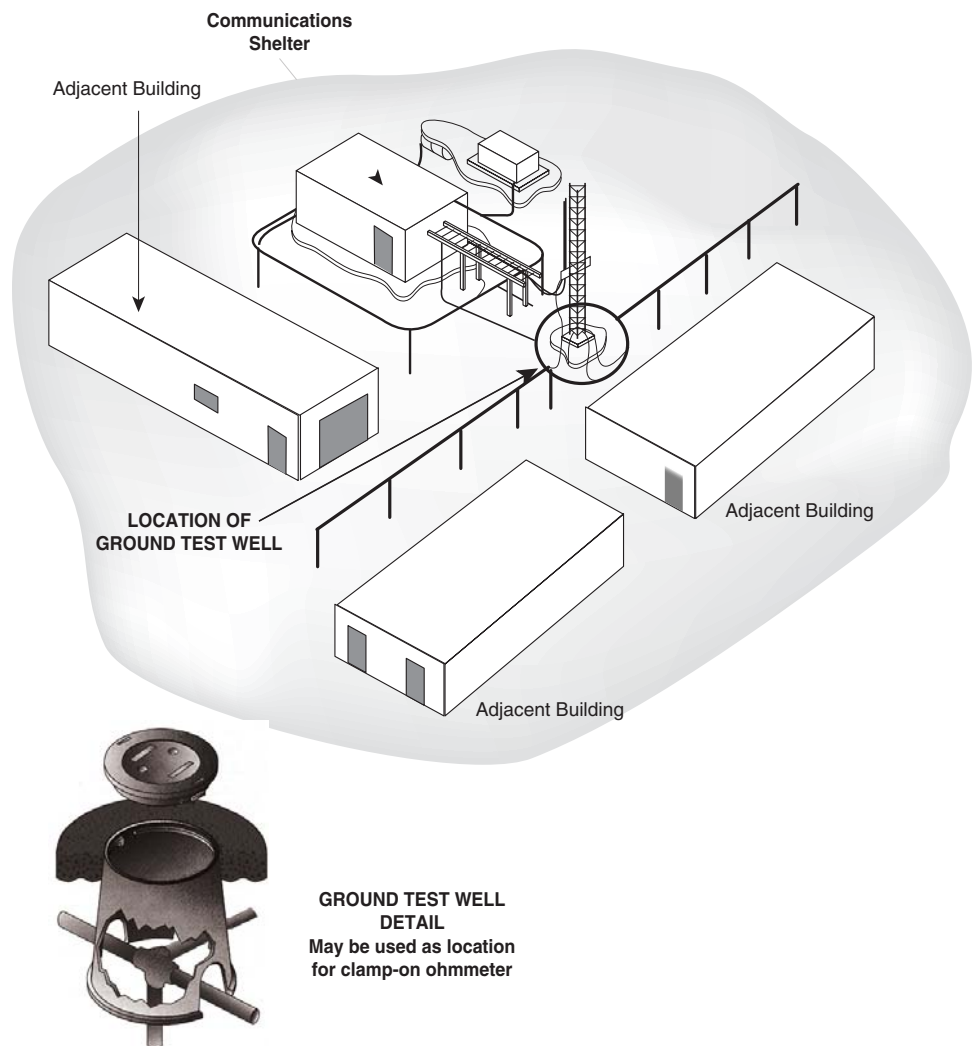

FIGURE D-1 SUPPLEMENTAL GROUNDING ELECTRODE SYSTEM WITH TEST LOCATION

D.3 FALL-OF-POTENTIAL METHOD TESTING PROCEDURE

D.3.1 TEST DESCRIPTION

The fall-of-potential test is the most widely accepted and recommended test method. This procedure is documented in ANSI/IEEE STD 81, BS 7430:1998, NFPA 7800-2004, and MIL-HDBK-419A and should be referred to for more details.

In the fall-of-potential test, two test rods are driven into the soil. These rods are placed in a straight line from an electrode in the grounding electrode system to be tested (referred to here as connection 'X'). One of the test rods, referred to here as rod 'Z', is placed at a known distance from the X connection. The other test rod (referred to here as rod 'Y') is placed at various distances between the X connection and rod Z. If a known current is applied between the X connecting point and rod Z, a potential difference (voltage drop) will exist between the X connection and rod Y. The fall-of-potential tester measures the voltage drop between the X connection and rod Y, and converts the measurement to a resistance reading using Ohm's Law ($R = E/I$). In this manner, the resistance at any point between the X connection and rod Z can be measured. The multiple readings obtained during this test are entered and plotted as data points on a graph. From the graph, the resistance of the grounding electrode system can be determined.

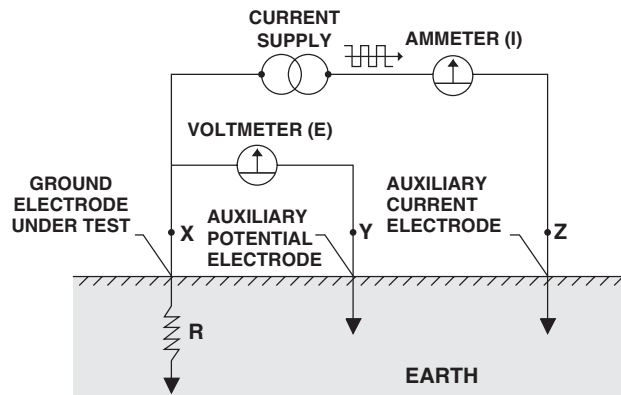

FIGURE D-2 MEASURING POTENTIAL DIFFERENCE BETWEEN RODS

D.3.2 REQUIRED TEST EQUIPMENT AND SUPPLIES

- Fall-of-potential ground resistance tester (with supplied operator's manual, test leads, test clips, and probes)
- Small sledgehammer
- Tape measure
- Safety glasses
- Insulated electrician's gloves

- Several photocopies of Table D-4 on page D-21. This is needed to record and keep track of several measurements across the site.
- Several photocopies of Figure D-5 on page D-12. This is needed to plot a graph of the resistance profile across the measurement area.

D.3.3 PREPARATION FOR TESTING

D.3.3.1 TESTING AREA REQUIREMENTS

This test requires a reference test rod (outer reference test probe Z) which **shall** be placed outside the field of influence of the grounding (earthing) electrode system. In many cases, this required location will be outside of the site property line. shows a typical site layout and its required spacing distance between the site and the reference test rod. As such, the following stipulations apply:

- For a **single grounding electrode system**, the distance of the reference probe **shall** be minimally 5 times, to preferably 10 times, the depth of the grounding electrode from the surface of the soil to the bottom of the buried electrode. For fall-of-potential testing distance measurements, the planar center of a single grounding electrode system is the electrode connecting point above ground.
- For a **multi-bonded/multi-grounding electrode system**, the distance of the reference probe **shall** be minimally 5 times, to preferably, 10 times the diagonal distance of the grounding electrode system. For fall-of-potential testing distance measurements, the planar center of a multi-bonded/multi-grounding electrode system is the extreme edge of the system in the direction of where the test probes are inserted. See Table D-1 for a resistance accuracy versus reference probe spacing (MIL-HDBK-419A).

TABLE D-1 RESISTANCE ACCURACY VS. PROBE C SPACING

Accuracy (%)	Probe Spacing
90	5 x diagonal under test
95	10 x diagonal under test
98	25 x diagonal under test
99	50 x diagonal under test

Use Table D-2 or Table D-3 to obtain the value for 10-times spacing distance between the site and the outer reference test probe (Z). (Table D-2 provides values in feet; Table D-3 provides values in metres.) For the minimum 5 times distance; divide the resulting numbers by 2.

NOTE: Any required permissions **shall** be obtained for accessing and placing a test probe on adjacent property before testing is attempted.

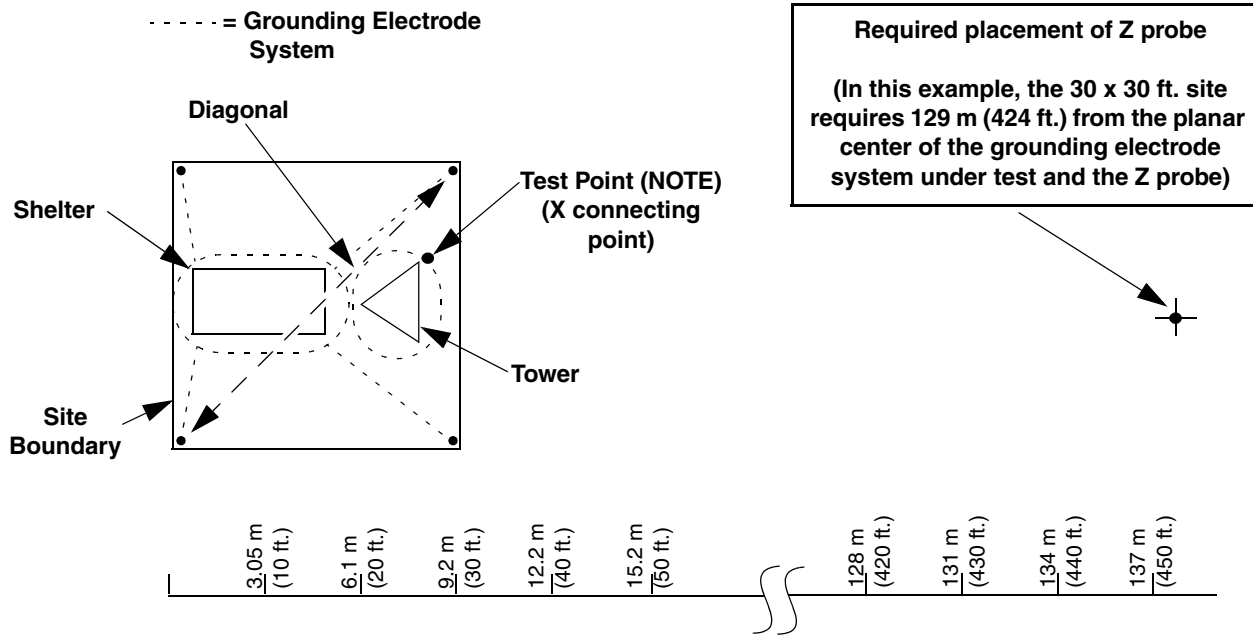

NOTE: Connection point of meter X clip is typically to external master ground bus.

FIGURE D-3 OUTER REFERENCE ELECTRODE (Z-PROBE) PLACEMENT FOR A TYPICAL SITE

TABLE D-2 REQUIRED Z-PROBE SPACING FOR SITE LENGTHS AND WIDTHS (IN FEET)

Site Width (ft)	Site Length (ft)									
	10	20	30	40	50	60	70	80	90	100
10	141	224	316	412	510	608	707	806	906	1005
20	224	283	361	447	539	632	728	825	922	1020
30	316	361	424	500	583	671	762	854	949	1044
40	412	447	500	566	640	721	806	894	985	1077
50	510	539	583	640	707	781	860	943	1030	1118
60	608	632	671	721	781	849	922	1000	1082	1166
70	707	728	762	806	860	922	990	1063	1140	1221
80	806	825	854	894	943	1000	1063	1131	1204	1281
90	906	922	949	985	1030	1082	1140	1204	1273	1345
100	1005	1020	1044	1077	1118	1166	1221	1281	1345	1414
110	1105	1118	1140	1170	1208	1253	1304	1360	1421	1487
120	1204	1217	1237	1265	1300	1342	1389	1442	1500	1562
130	1304	1315	1334	1360	1393	1432	1476	1526	1581	1640
140	1404	1414	1432	1456	1487	1523	1565	1612	1664	1720
150	1503	1513	1530	1552	1581	1616	1655	1700	1749	1803
160	1603	1612	1628	1649	1676	1709	1746	1789	1836	1887
170	1703	1712	1726	1746	1772	1803	1838	1879	1924	1972
180	1803	1811	1825	1844	1868	1897	1931	1970	2012	2059
190	1903	1910	1924	1942	1965	1992	2025	2062	2102	2147
200	2002	2010	2022	2040	2062	2088	2119	2154	2193	2236

TABLE D-3 REQUIRED Z-PROBE SPACING FOR SITE LENGTHS AND WIDTHS (IN METRES)

Site Width (m)	Site Length (m)									
	3	6	9	12	15	18	21	24	27	30
3	43	68.3	96.3	125.6	155.4	185.3	215.5	245.7	276.1	306.3
6	68.3	86.3	110	136.2	164.3	192.6	221.9	251.5	281	310.9
9	96.3	110	129.2	152.4	177.7	204.5	232.3	260.3	289.3	318.2
12	125.6	136.2	152.4	172.5	195	219.8	245.7	272.5	300.2	328.3
15	155.4	164.3	177.7	195	215.5	238	262.1	287.4	313.9	340.8
18	185.3	192.6	204.5	219.8	238	258.8	281	304.8	329.8	355.4
21	215.5	221.9	232.3	245.7	262.1	281	301.8	324	347.5	372.2
24	245.7	251.5	260.3	272.5	287.4	304.8	324	344.8	367	390.4
27	276.2	281	289.3	300.2	313.9	329.8	347.5	367	388	410
30	306.3	310.9	318.2	328.3	340.8	355.4	372.2	390.4	410	431
33	336.8	340.8	347.5	356.6	368.2	381.9	397.5	414.5	433.1	453.2
37	367	371	377	385.6	396.2	409	423.4	439.5	457.2	476
40	397.5	400.8	406.6	414.5	424.6	436.5	449.9	465.1	482	499.9
43	428	431	436.5	443.8	453.2	464.2	447	491.3	507.2	524.3
46	458.1	461.2	466.3	473	482	493	504.4	518.2	533.1	549.6
49	488.6	491.3	496.2	502.6	510.8	520.9	532.2	545.3	559.6	575.2
52	519	521.8	526	532.2	540.1	549.6	560.2	572.7	586.4	601
54.9	549.6	552	556.3	562	569.4	578.2	588.6	600.5	613.3	627.6
57.9	580	582.2	586.4	591.9	598.9	607.2	617.2	628.5	640.7	654.4
60.1	610.2	612.6	616.3	621.8	628.5	636.4	645.9	656.5	668.4	681.5

D.3.3.2 SITE AC POWER DISCONNECT REQUIREMENTS

This test requires disconnection of the site grounding (earthing) electrode system from the power company grounded conductor (may be a neutral wire). This is required in order to allow testing that is limited only to the site grounding electrode system. Attempting to perform measurements while the site remains connected to the extensive ground/ neutral system of the power company artificially enhances the grounding electrode system reading, resulting in measurement error. Therefore, for an existing site supplied by commercial AC power that contains a neutral wire which is part of an extensive power company grounding system, the following steps must be taken first:

1. Coordinate the test with the customer and/or site owner and all other affected parties.
2. Arrange for the site to have the power company AC power turned off. If the site must remain operational while testing is being done, the site will have to be switched to a back-up power source if it is available.



WARNING

Check for current on the grounding electrode conductor before disconnecting. Never disconnect the ground of a live circuit. Disconnecting the ground of a live circuit could cause death or severe injury.

3. Have the site grounding electrode system isolated from the power company grounded conductor (may be a neutral wire) by a qualified electrician, ensuring that it has no secondary path to the site via a conduit or other connection (this can be verified with the use of a multi-meter). The only way to achieve this (especially at a communications site with a multi-bonded/multi-grounding electrode system) may be having the power company grounded conductor (may be a neutral wire) disconnected from the site.
4. Remove any other grounding electrode connection that may influence the measurement of the on-site grounding electrode system, such as the telephone company ground connection and metallic water/gas pipes.

D.3.3.3 FALL-OF-POTENTIAL TEST PROCEDURE

Figure D-4 shows typical ground resistance tester connections and test probe orientations.



WARNING

Follow ground resistance tester manufacturer's warning and caution information when using tester. Follow furnished instructions when inserting and removing test rods into soil. Make certain this procedure is fully understood before proceeding with test.

Perform the fall-of-potential test as follows:

1. On Ground Resistance Tester, connect test leads to the **X**, **Y**, and **Z** terminals.
2. Short the **X** and **Xv** connections on the Ground Resistance Tester.
3. Connect the **X** lead to the grounding electrode system under test. (This is typically via a test clip connection to an external ground bus bar.)

4. Connect the **Y** lead to the measurement (**Y**) probe.
5. Determine the required placement of outer reference probe (**Z**) in accordance with paragraph “Testing Area Requirements” on page D-5.
6. Place the outer reference probe (**Z**) into the soil at the determined location. Connect the outer reference probe (**Z**) to meter terminal **Z**.
7. Note the distance of the outer reference probe (**Z**) from the grounding electrode system (this distance will be used in determining subsequent measurements). On the photocopy of the Fall-of-Potential Test Worksheet, write this distance in the “100%” space.
8. Place the measurement probe (**Y**) in the soil starting close to the area of the grounding electrode system under test. Take a measurement.
9. On the photocopy of the Fall-of-Potential Test Worksheet (page D-21), write the reading in the “0%” row of the worksheet.
10. Place the measurement probe (**Y**) at 5% of the distance between the grounding electrode system '**X**' connection and the outer reference probe (**Z**). Take a measurement.

Example: Assuming a “100%” distance of 131 m (430 ft.), **Y** probe would be placed at 6.55 m (21.5 ft.) for “5%” measurement location.

NOTE: Placement of the measurement probe (**Y**) must be along a straight path between the grounding electrode system '**X**' connection and the outer reference probe (**Z**).

11. On the photocopy of the Fall-of-Potential Test Worksheet, write down the reading in the appropriate row of the worksheet.
12. Place the measurement probe (**Y**) at 10% of the distance between the grounding electrode system '**X**' connection and the outer reference probe (**Z**). Take a measurement.

Example: Assuming a “100%” distance of 131 m (430 ft.), **Y** probe would be placed at 13.1 m (43 ft.) for “10%” measurement location.

13. On the photocopy of the Fall-of-Potential Test Worksheet (, write down the reading in the appropriate row of the worksheet.
14. At every 10% point, repeat steps 12 and 13 for the remaining spaces on the worksheet.
15. On the photocopy of Fall-of-Potential Test Graph Form, plot a graph of the measured resistances for all points listed on the worksheet.
16. Using Figure D-5, assess the test results as follows:
 - Valid Test: At approximately 62% of the total distance (“100%” distance), a plateau or “flat spot” should be noticeable in the plot, as shown in “VALID TEST GRAPH” in Figure D-5. The resistance at this plateau is the validated resistance of the system under test.
 - Invalid Test Graph (insufficient distance of **Z**-probe): If there is no plateau on the plot, shown in “INVALID TEST GRAPH (Z-Probe Spacing)” in Figure D-5, the test is considered invalid because the **Z** probe is not far enough from the **X** probe.

- Invalid Test Graph (erroneous connection to neutral): If there is no plateau on the plot, shown in “INVALID TEST GRAPH (Connection to neutral)” in Figure D-5, the test is considered invalid because an erroneous connection of the grounding electrode system to a power company neutral, or other utility ground, remains.

NOTE: If the electrical service provided by the Power Company does not contain a neutral wire that is bonded to an extensive power company grounding system, such as a 3-phase delta service, the fall-of-potential test can be performed on the grounding electrode system without disconnecting it from the power company. This is because the neutral wire is locally derived at the transformer and is not part of the extensive Power Company grounding system. All other utility connections must still be removed, such as the telephone company ground connection and ground through water/gas metallic pipes.

NOTE: If sufficient access area exists, the entire procedure above should be repeated in different directions facing away from the center of the grounding electrode system. Repeating the procedure is recommended in case metal pipes or similar conductive objects are buried in a given test area. The presence of metal pipes or similar conductive objects may result in an inaccurate reading.

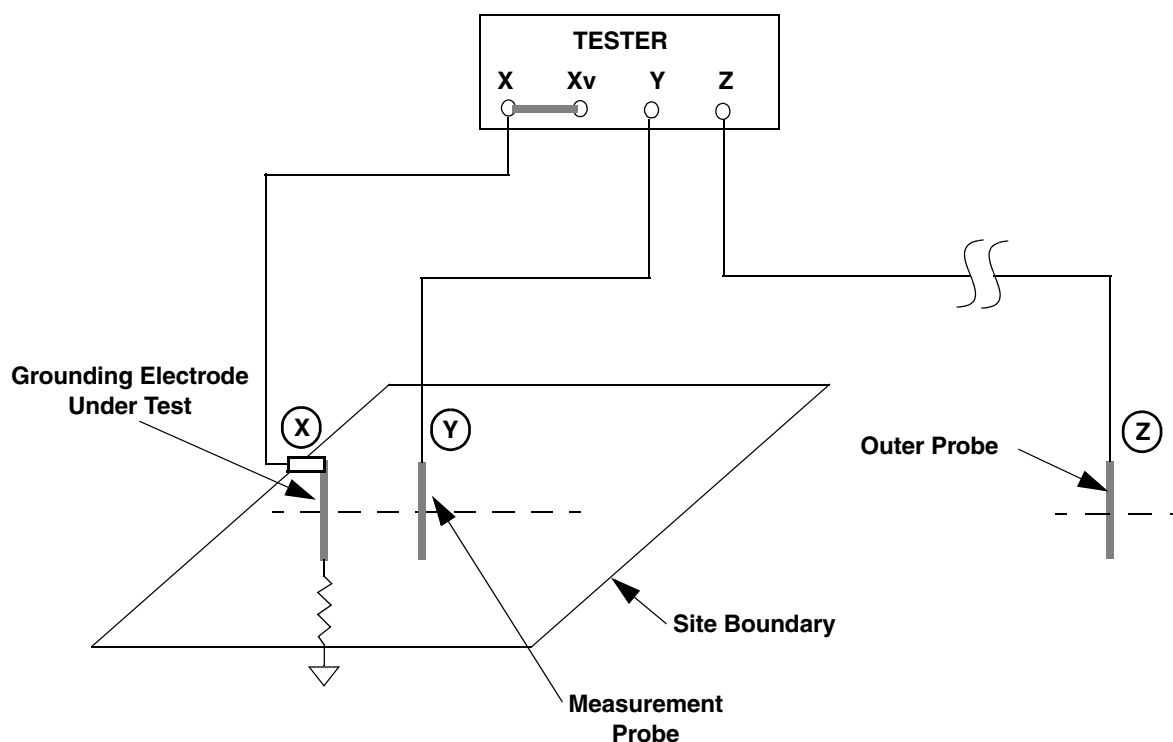
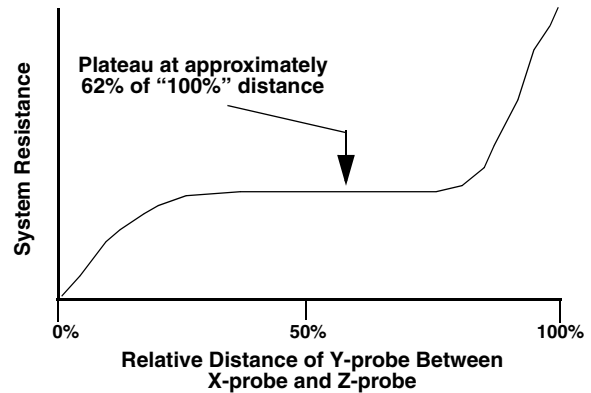

FIGURE D-4 TYPICAL GROUND RESISTANCE TESTER CONNECTION

VALID TEST GRAPH

At approximately 62% of the total distance, a plateau or “flat spot” should be noticeable in the plot. The resistance at this plateau is the resistance of the system under test.



INVALID TEST GRAPH (Z-Probe Spacing)

The Z probe is not placed far enough from the grounding electrode system.

Reposition Z-probe farther away from X connecting point and repeat test.

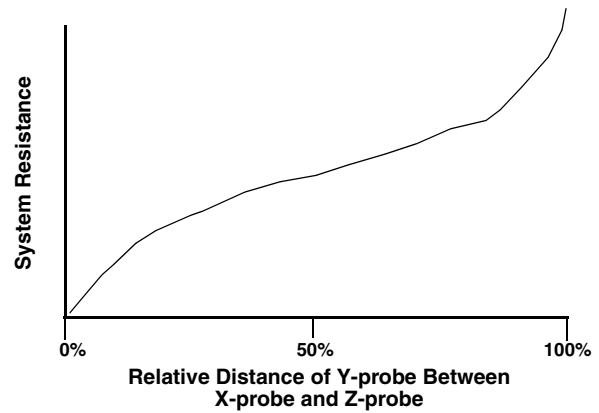

INVALID TEST GRAPH (Connection to neutral)

Due to a connection that still exists to the Power Company neutral conductor or other utility, the resulting curve has very little change until the point nearest the remote current probe. No valid plateau exists.

Have connection removed and repeat test.

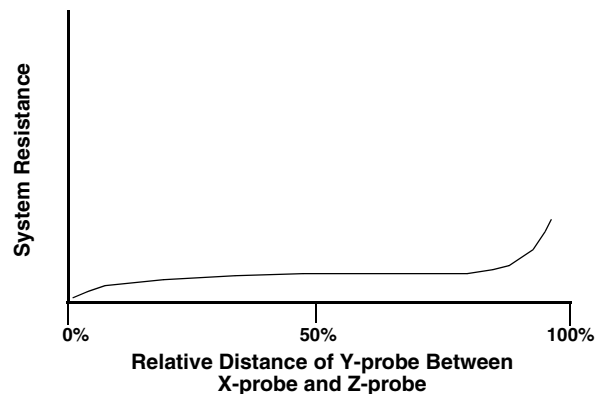

FIGURE D-5 TYPICAL FALL-OF-POTENTIAL TEST GRAPH RESULTS

D.4 CLAMP-ON OHMMETER TESTING PROCEDURE

The Clamp-on ohmmeter test can be performed on both single grounding (earthing) electrode and multi-bonded/multi-grounding electrode system (such as at a communications site). However, the test can only be accurately performed on sites supplied by commercial power.

For a single grounding electrode system, the test is considered very reliable and can be easy to perform. However, for a multi-bonded/multi-grounding electrode system, the test can be more difficult to perform and may result in an error reading due to parallel paths. The test procedure in this section has provisions to help avoid such errors.

NOTE: If the electrical service provided by the power company does not contain a neutral wire that is bonded to the extensive power company ground system (such as with a 3-phase delta service), the clamp-on ohmmeter will not give an accurate reading. In these cases, this is because the neutral wire is locally derived at the transformer and is not part of the extensive power company grounding system; therefore, it cannot provide an effective low resistance return path for the meter.

D.4.1 TEST DESCRIPTION

The clamp-on ohmmeter works on the basis of injecting current, from a known voltage source, into the grounding (earthing) electrode system in order to create a current flow whose value is a function of the grounding electrode system resistance. The test current flows from the grounding electrode system through the earth, returning to the grounding electrode system via the power company's multi-grounded neutral wire. The meter then measures this current and converts the measurement to a resistance reading using Ohm's Law ($R = E/I$). As such, the meter displays a resistance of the grounding electrode system in ohms. Because the power company's grounding system is so extensive, the meter considers it to be of negligible value and disregards its effect on the reading.

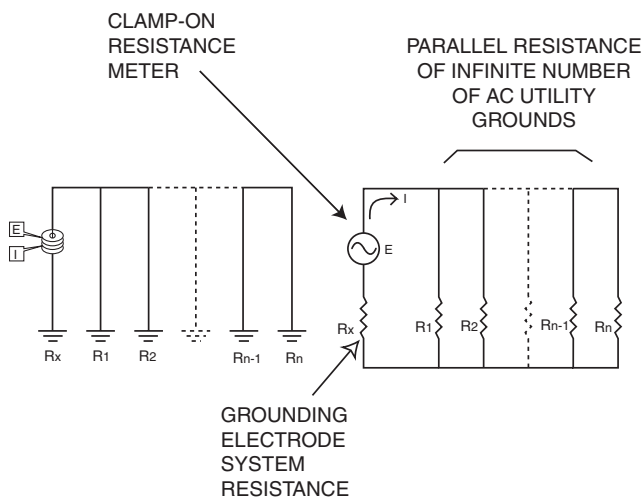

FIGURE D-6 CLAMP-ON GROUND RESISTANCE MEASUREMENT

D.4.2 REQUIRED TEST EQUIPMENT AND SUPPLIES

- Clamp-on ohmmeter/ammeter
- Insulated electrician's gloves
- A photocopy of Table 4-5 on page D-25. This will be needed to record measurements.

D.4.3 PREPARATIONS FOR TESTING

D.4.3.1 SITE AC POWER DISCONNECT REQUIREMENTS

This test does not require disconnection of the site grounding (earthing) electrode system from the power company grounded conductor (may be a neutral wire). The power company grounded conductor is required in order for the meter to display valid reading. However, for a multi-bonded/multi-grounding electrode system it may be necessary to de-energize the site from commercial power if significant unbalanced current flow is present on the grounded conductor. Unbalanced current flow may create noise on the meter, resulting in the inability of the meter to display an accurate reading; the noise condition is typically indicated by the clamp-on ohmmeter.

NOTE: A backup generator may be used during the clamp-on ohmmeter test if the communications site requires power.

For a site supplied by commercial AC power that contains a neutral wire which is part of an extensive power company grounding system and the site contains a multi-bonded/multi-grounding electrode system, the following steps must be taken first:

1. Coordinate the test with the customer and/or site owner and all other affected parties.
2. Arrange for the site AC power to be turned off and the site switched to a back-up power source if it is available. Any current on the neutral wire (even if less than 5 amps) can result in a false reading. It is therefore recommended that the commercial power be turned off in order to eliminate any currents on the neutral wire that can affect the meter's ability to give an accurate reading.
3. It may be necessary to remove other utility ground connections (such as telephone), depending on their location. This is typically required for a multi-bonded/multi-grounding electrode system.

D.4.3.2 CLAMP-ON OHMMETER TEST PROCEDURES



CAUTION

Follow clamp-on ohmmeter manufacturer's warning and caution information when using tester.

Depending on whether site uses a Single Grounding (Earthing) Electrode system or Multi-bonded/Multi-Grounding Electrode system, proceed to paragraph "Single Grounding (Earthing) Electrode System Testing (or Equivalent)" on page D-15 or "Multi-Bonded/Multi-Grounding (Earthing) Electrode System Testing" on page D-17 as applicable.

D.4.3.3 SINGLE GROUNDING (EARTHING) ELECTRODE SYSTEM TESTING (OR EQUIVALENT)

For a site using a single grounding electrode system (or equivalent), perform test as follows:

1. Locate the grounding electrode connection outside of the shelter, or the single wire connecting to the grounding electrode.
2. (See Figure D-7.) Clamp the meter around the grounding electrode connecting wire, making sure that the meter is positioned at a location below any other utility connection (such as the telephone company ground or a water pipe).
3. Set the meter to the **Amps** scale and check the grounding electrode for current.

If 5 amps or more are on the grounding electrode conductor, the test may not be able to be performed due to the design of some meters. If the current on the ground wire is less than 5 amps, a measurement may be taken if the meter does not indicate any noise or other errors.



CAUTION

Any significant current on the grounding electrode conductor could indicate a serious problem and should be immediately investigated by qualified personnel.

4. Set the meter to the **Ohms** scale and note the reading; if no noise or other errors are indicated on the meter, this is the resistance of the grounding electrode system under test.

Record the reading on the photocopy of the Clamp-on Ohmmeter/Ammeter Test worksheet (page D-25).

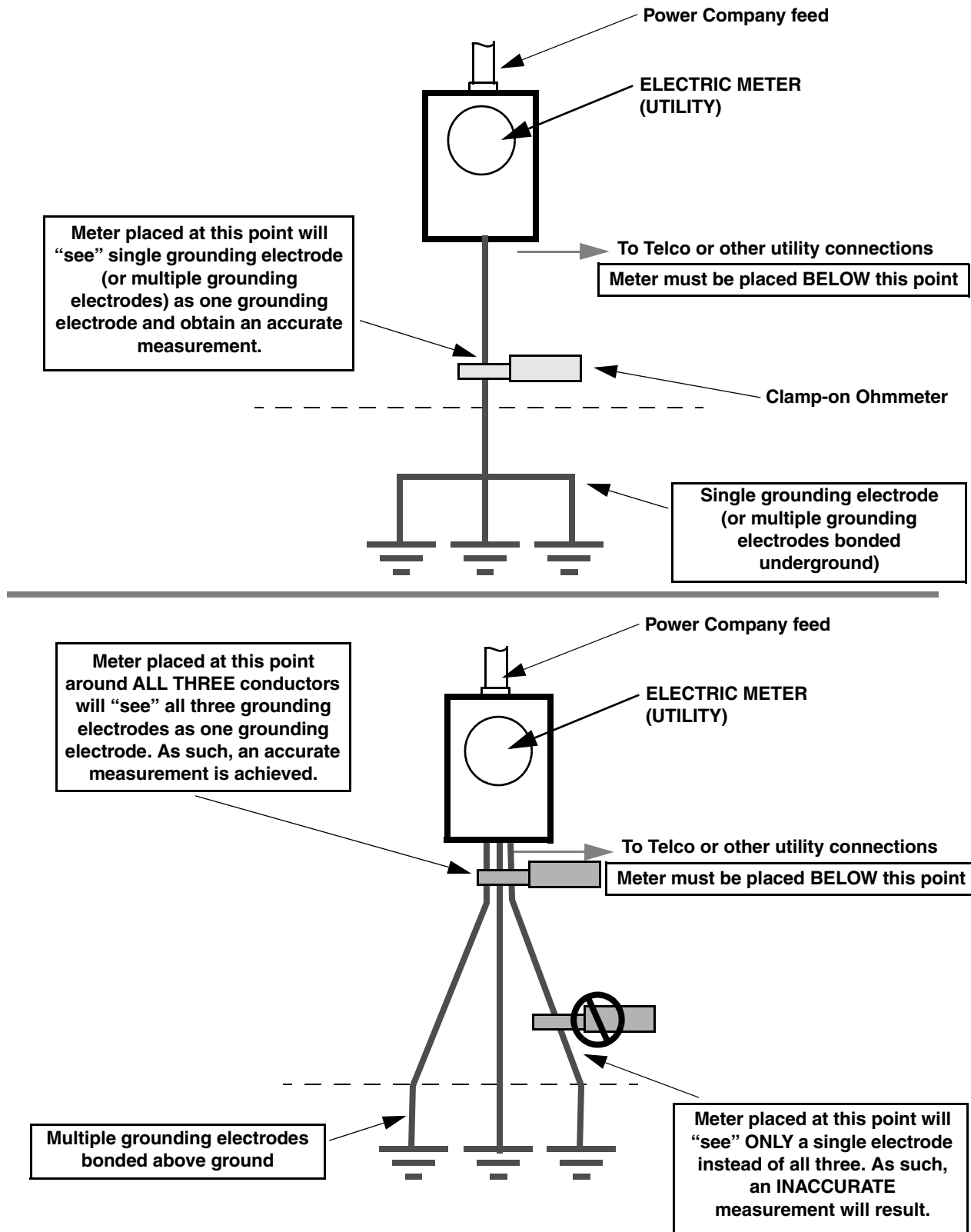

FIGURE D-7 CLAMP-ON OHMMETER PLACEMENT FOR SINGLE GROUNDING ELECTRODE SYSTEM

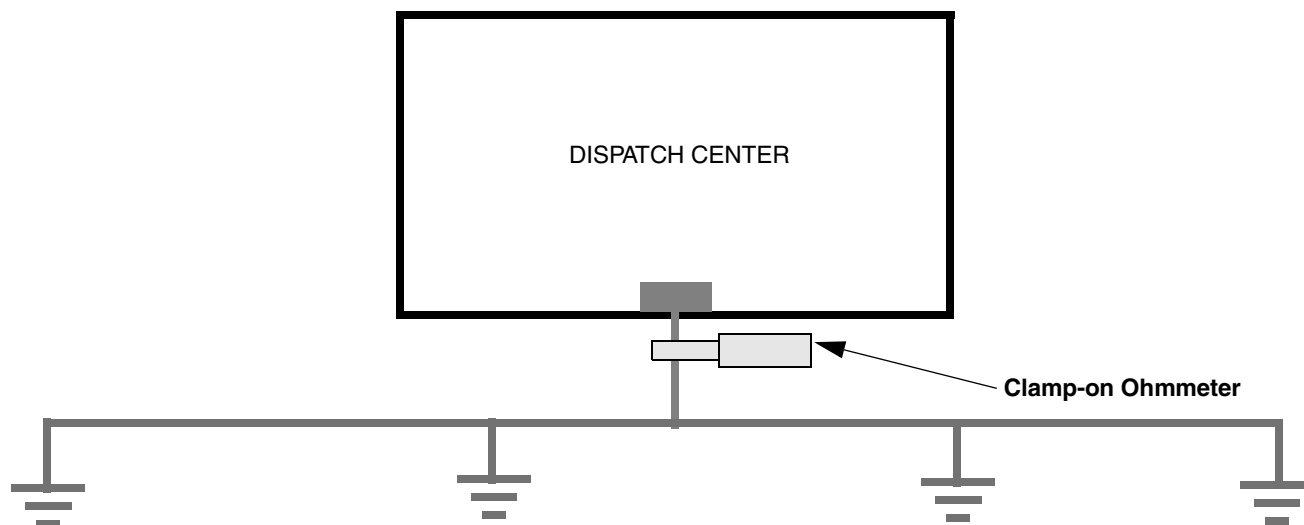

FIGURE D-8 CLAMP-ON OHMMETER PLACEMENT FOR PARALLEL GROUNDING ELECTRODE SYSTEM

D.4.3.4 MULTI-BONDED/MULTI-GROUNDING (EARTHING) ELECTRODE SYSTEM TESTING

For a site using a multi-bonded/multi-grounding electrode system, perform the test as follows:

NOTE: This test requires the site grounding electrode system to be bonded to the power company neutral wire, but may require all non-balanced (phase-to-neutral) loads within the site to be switched off.

1. Coordinate the test with the customer and/or site owner and all other affected parties. Have all non-balanced (phase-to-neutral) loads switched off from the system under test.

NOTE: Unbalanced current flow (current on the neutral wire) within the site may affect the ability of the meter to achieve an accurate reading. As such, arrange for any non-balanced (phase-to-neutral) loads within the site to be electrically de-energized, yielding a neutral connection with no current flow on it. The easiest way to accomplish this is to completely de-energize the AC power to the site. Any current on the neutral wire (even if less than 5 amps) can result in a false reading.

2. Disconnect any other utility connections to the grounding electrode system, such as the telephone company ground connection or paths through metallic pipes.
3. Have the Power Company neutral wire exposed by a qualified electrician at the point of entry into the site, ensuring that it has no secondary path to the site via a conduit or other connection.

NOTE: The neutral wire is used for a measurement because it is the only point in a site where all of the site grounding connections are common over a single conductor. As such, measuring at this point allows the clamp-on ohmmeter to “view” all of the various connections as one single grounding electrode.

In many cases, the first neutral-ground bonding point may not be at the site building electrical service panel, but rather at the meter box where the neutral is bonded to the conduit that enters the building. As such, service that uses a PVC conduit typically has the first neutral-ground bonding point at the electrical service panel; service that uses metallic conduit may have the first neutral-ground bonding point at the meter.

If a measurement is attempted at the electrical service panel where neutral-ground bonding is at the meter, an erroneous closed-loop reading on the meter will result instead of a reading of the grounding electrode system.

NOTE: See the meter user's manual to determine a meter indication, if any, showing that the meter is reading a closed loop rather than the actual grounding electrode system. The closed loop reading may be caused by a ground loop through a conduit, electrical service meter base or any other electrical panel board. It can also be an indication that there is another utility connected, such as a water pipe or the Telephone Company ground.

4. Depending on location of first neutral-ground bonding point, attach the clamp-on ohmmeter around the neutral wire as shown in Figure D-9 or Figure D-10.
5. Set the meter to the **Amps** scale and verify there is no significant current on the neutral wire.
6. Set the meter to the **Ohms** scale and note the reading; if no noise or other errors are indicated on the meter, this is the resistance of the grounding electrode system under test.

Record the reading on the photocopy of the clamp-on ohmmeter/ammeter test worksheet (page D-25).

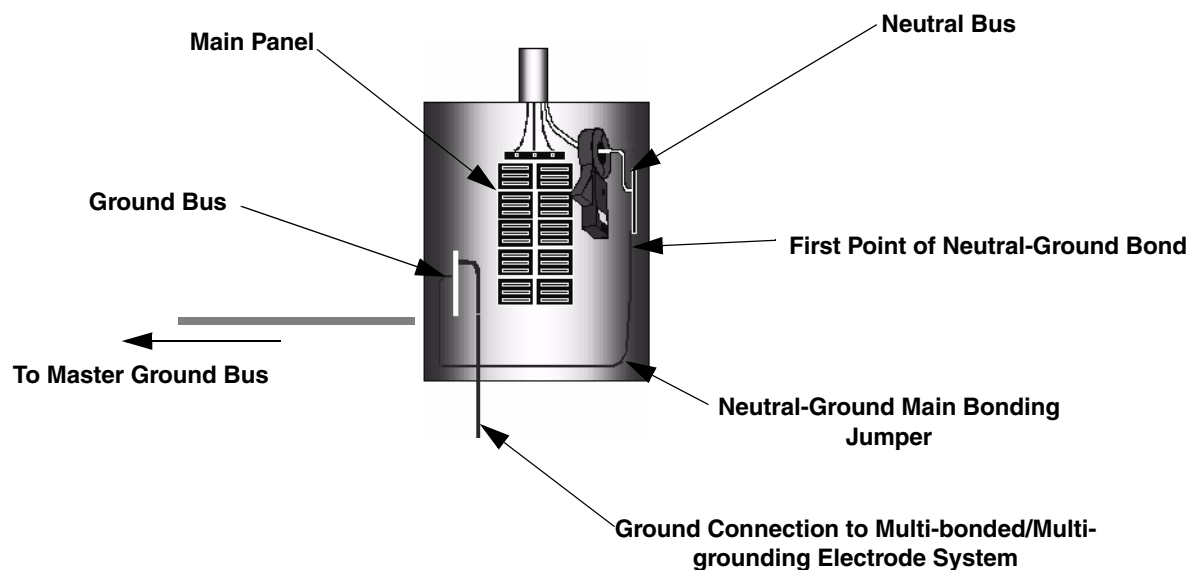

FIGURE D-9 CLAMP-ON OHMMETER PLACEMENT FOR MULTI-BONDED/MULTI-GROUNDING ELECTRODE SYSTEM (NEUTRAL-GROUND BOND AT SERVICE PANEL)

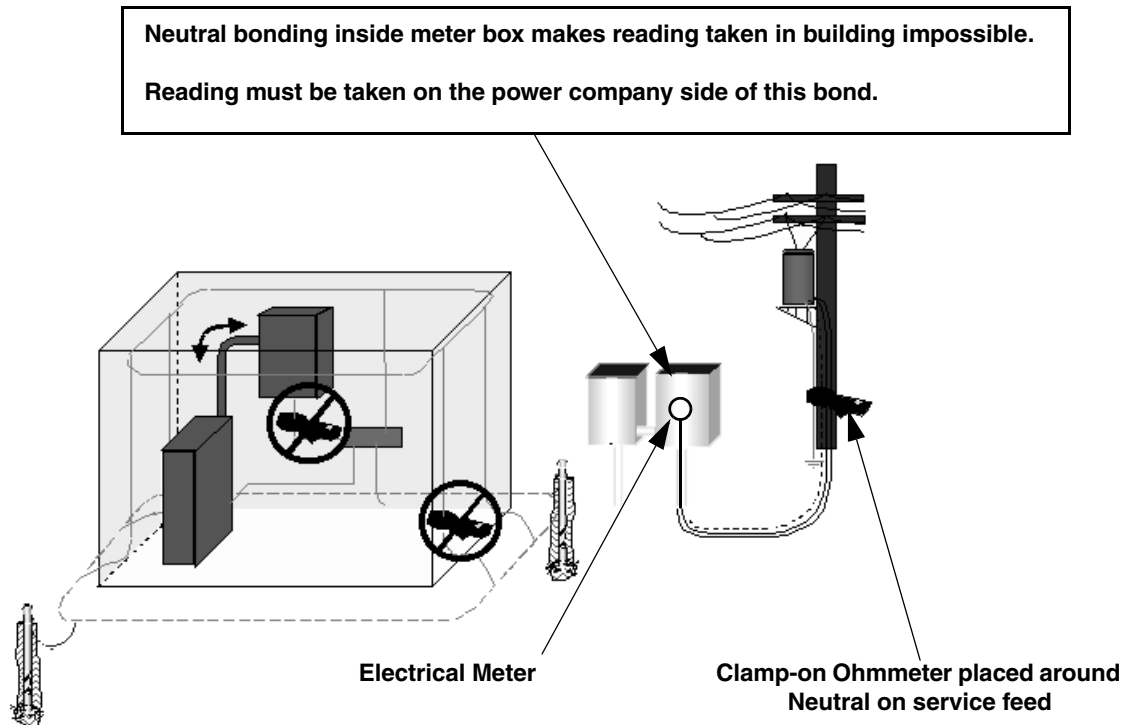

FIGURE D-10 CLAMP-ON OHMMETER PLACEMENT FOR MULTI-BONDED/MULTI-GROUNDING ELECTRODE SYSTEM (NEUTRAL-GROUND BOND AT METER BOX)

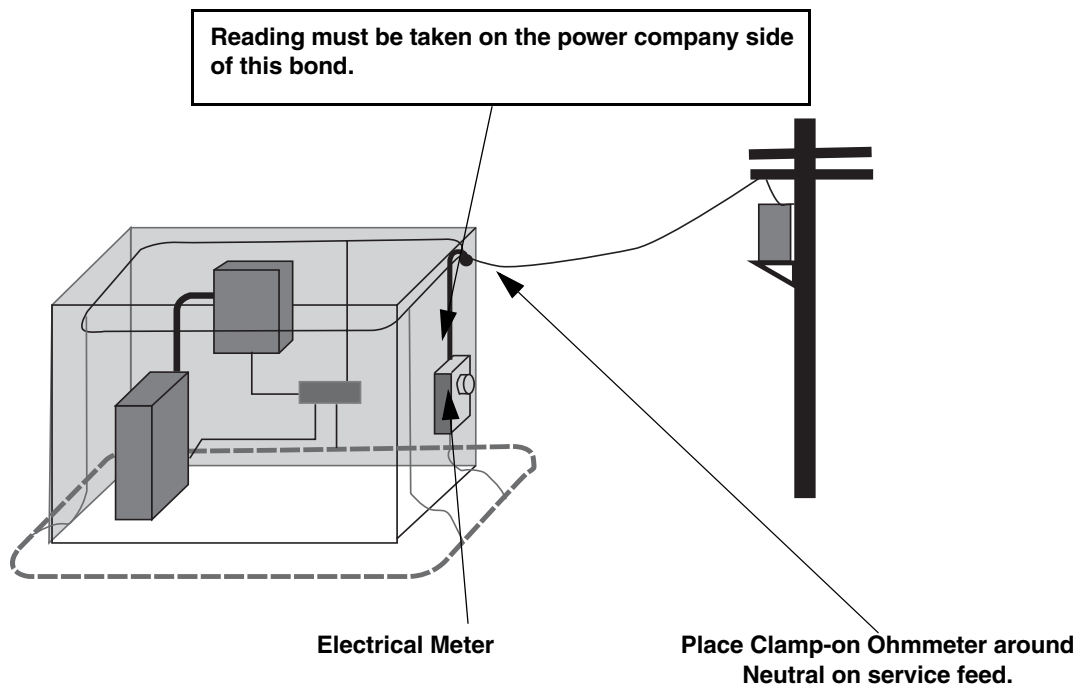

FIGURE D-11 CLAMP-ON OHMMETER PLACEMENT FOR MULTI-BONDED/MULTI-GROUNDING ELECTRODE SYSTEM (OVERHEAD SERVICE)

D.5 COMBINING SOIL RESISTIVITY TESTING WITH CLAMP-ON OHMMETER

Providing site soil resistivity readings along with clamp-on ohmmeter readings to an engineering firm specializing in grounding electrode system design is at times the only method available for grounding electrode system resistance verification.

Typically, the engineering firm will use the supplied data which is entered into a specialized computer program that determines grounding electrode system resistance for the site. The data required is as follows:

- The results obtained from a soil resistivity test
- Individual grounding electrode system component testing data from the clamp-on ohmmeter
- Grounding electrode system layout map/specifications
- Detailed “as-built” drawings for the site

TABLE D-4 FALL-OF-POTENTIAL TEST WORKSHEET

Distance from Grounding Electrode System Grid		Test Data
%	ft (m)	Ohms (Ω)
0%		
5%		
10%		
20%		
30%		
40%		
50%		
60%		
70%		
80%		
90%		
100%		
Test completed by:		
Date:		
Client / Project:		
Site Location/ID:		
Ground Resistance Tester		
Model:		
S/N:		
Calibration date:		
Soil Description:		
Ambient Conditions		
Temperature:		
Present conditions (dry, rain, snow):		
Date of last precipitation:		
Notes:		

THIS PAGE INTENTIONALLY LEFT BLANK.

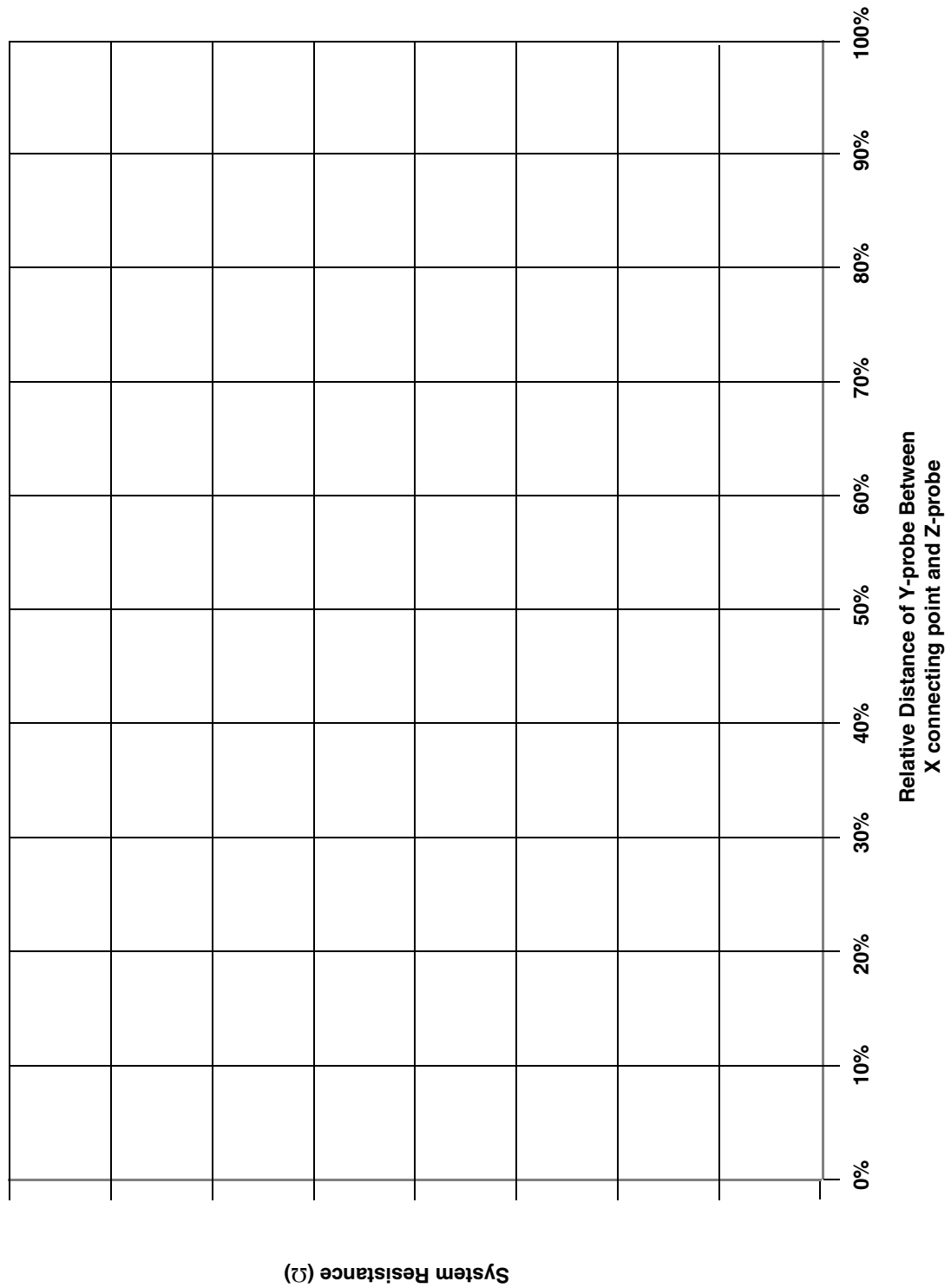

FIGURE D-12 FALL-OF-POTENTIAL TEST GRAPH FORM

THIS PAGE INTENTIONALLY LEFT BLANK.

TABLE 4-5 CLAMP-ON OHMMETER/AMMETER TEST WORKSHEET

Points Tested	Ohms	Amps
Test Point 1:		
Test Point 2:		
Test Point 3:		
Test Point 4:		
Test Point 5:		
Test Point 6:		
Test Point 7:		
Test completed by:		
Date:		
Client / Project:		
Site Location/ID:		
Ground Resistance Tester		
Model:		
S/N:		
Calibration date:		
Soil Description:		
Ambient Conditions		
Temperature:		
Present conditions (dry, rain, snow):		
Date of last precipitation:		
Notes:		

THIS PAGE INTENTIONALLY LEFT BLANK.

GENERAL CONVERSIONS AND FORMULAS

TABLE E-1 CONVERSION FORMULAS

Conversion Formulas
Linear Measure
miles (statute) = miles (nautical) x 1.1508
mils = in x (1 x 10 ³)
ft = in/12
yard = ft/3
miles = ft/5280
Volume
ounce (fluid) = qt x 32
pint = qt x 2
gallon (US) = qt/4
gallon (imperial) = gallon (US)/0.8327
gallon (US) = cu. ft. / 7.477
Avoirdupois Weight
ounce = lb x 16
short ton = lb/2000
long ton (UK) = lb/2240
Temperature
°C = (°F-32)/1.8
°F = (°C·1.8) + 32
°K (Kelvin; Celsius absolute) = °C + 273.18
°R (Rankine; Fahrenheit absolute) = °F + 459.72
Angular Measurement
radians = degrees x 0.0145
revolutions = radians x 2π
Sinusoidal Waveform Measurement
rms = average x 1.11
peak = average x 1.57
peak-to-peak = average x 3.14
average = rms x 0.9
peak = rms x 1.414
peak-to-peak = rms x 2.828
average = peak x 0.637
rms = peak x 0.707
peak-to-peak = peak x 2
Power
hp = W / 746

TABLE E-1 CONVERSION FORMULAS (CONTINUED)

Conversion Formulas
BTU/hr = W / 0.293
Energy
BTU = KWh / (2.9306 x 10 ⁻⁴)
Metric Conversion Formulas
Linear Measure
cm = in x 2.54
in = centimeters x 0.3937
in = meters x 39.37
yards = meters x 1.0936
ft = kilometers x 3281
kilometers = miles (statute) x 1.6093
micron = meter / 10 ⁻⁶
millimicron = meter / 10 ⁻⁹
Angstrom units = meter / 10 ⁻¹⁰
Area
cm ² = sq. in / 0.155
m ² = sq. ft / 10.76
square miles = km ² /0.3816
km ² = 0.3861 square mile
Liquid Measure
US gallon = liter x 0.2642
fluid ounce = milliliter x 0.0338
Volume
liter = 1000 cm ³ = cu. in / 61.02
Pressure
Pa = N/m ² = PSF x 47.85
Pa = PSI x 6891
atm = PSF x 2117
Weight
ounce = gram x 0.03527
lb = kilogram x 2.2046
long ton (UK) = metric ton x 1.1023
gram = ounce x 28.35
kilogram = lb x 0.4536
metric ton = long ton (UK) x 0.9072
tonne = ton (US) x 1.102
Torque
N·m = lbf·ft x 1.356
lbf·ft = N·m x 0.7376

TABLE E-2 METRIC EQUIVALENTS OF AMERICAN WIRE GAUGE (AWG)

AWG	Area			Diameter	
	c mils	inches ¹	mm ²	mils	mm
28	159.8	0.000126	0.804	12.6	0.320
26	254.1	0.000200	0.128	15.9	0.404
24	404.0	0.000317	0.205	20.1	0.511
22	642.4	0.000505	0.324	25.3	0.643
19	1288	0.001012	0.653	35.9	0.912
18	1624	0.001276	0.823	40.3	1.02
16	2583	0.002028	1.31	50.8	1.29
15	3257	0.002558	1.65	57.1	1.45
14	4107	0.003225	2.08	64.1	1.63
13	5178	0.004067	2.63	72.0	1.83
12	6530	0.005129	3.310	80.0	2.05
11	8234	0.006467	4.17	90.7	2.304
10	10380	0.008155	5.261	101.9	2.588
9	13090	0.01028	6.631	114.4	2.906
8	16510	0.01297	8.367	128.5	3.264
7	20820	0.01635	10.55	144.3	3.665
6	26250	0.02062	13.30	162.0	4.115
5	33100	0.02600	16.77	181.9	4.520
4	41740	0.03278	21.15	204.3	5.189
3	52640	0.04134	26.67	229.4	5.827
2	66370	0.05213	33.62	257.6	6.543
1	83690	0.06573	42.41	289.3	7.346
1/0	10550	0.08289	53.49	324.9	8.252
2/0	13310	0.1045	67.43	364.8	9.266
3/0	167800	0.1318	85.01	409.6	10.40
4/0	211600	0.1662	107.26	460.0	11.68
	250000		126.70	500.0	12.70
	350000		177.39		
	500000		253.35		
	750000		380.13		

1. All conductors are solid except AWG 2 and coarser which are stranded.

TABLE E-3 TEMPERATURE CONVERSION CHART

°C	°F	°C	°F	°C	°F	°C	°F
-60	-76	-25	-13	5	41	45	113
-55	-67	-20	-4	10	50	50	122
-50	-58	-17.8	0	15	59	55	131
-45	-49	-15	5	20	68	60	140
-40	-40	-10	14	30	86	65	149
-35	-31	-5	23	35	95	70	158
-30	-22	0	32	40	104		

NOTE: °C= (°F-32) / 1.8
°F= (°C·1.8) + 32

TABLE E-4 ENGINEERING PREFIXES

Prefix	Symbol	Value	Example
tera	T	1×10^{12}	terahertz (THz)
giga	G	1×10^9	gigahertz (GHz)
mega	M	1×10^6	megahertz (MHz)
kilo	k	1×10^3	kilohertz (kHz)
centi	c	1×10^{-2}	centimeter (cm)
milli	m	1×10^{-3}	millihenry (mH)
micro	μ	1×10^{-6}	microfarad (μF)
nano	n	1×10^{-9}	nanosecond (nsec)
pico	p	1×10^{-12}	picofarad (pF)

TABLE E-1 DECIMAL EQUIVALENT DRILL SIZES

Fractional Drill Size (in.)	Decimal Equivalent (in.)	Metric Equivalent (mm)	Fractional Drill Size (in.)	Decimal Equivalent (in.)	Metric Equivalent (mm)
1/64	0.0156	0.397	33/64	0.5156	13.097
1/32	0.0313	0.794	17/32	0.5313	13.494
3/64	0.0469	1.191	35/64	0.5469	13.891
1/16	0.0625	1.588	9/16	0.5625	14.287
5/64	0.0781	1.985	37/64	0.5781	14.684
3/32	0.0938	2.381	19/32	0.5938	15.081
7/64	0.0194	2.778	39/64	0.6094	15.478
1/8	0.125	3.175	5/8	0.625	15.875
9/64	0.1406	3.572	41/64	0.6406	16.272
5/32	0.1563	3.969	21/32	0.6563	16.669
11/64	0.1719	4.366	43/64	0.6719	17.067
3/16	0.1875	4.762	11/16	0.6875	17.463
13/64	0.2031	5.159	45/64	0.7031	17.86
7/32	0.2188	5.556	23/32	0.7188	18.238
15/64	0.2344	5.953	47/64	0.7344	18.635
1/4	0.25	6.35	3/4	0.75	19.049
17/64	0.2656	6.747	49/64	0.7656	19.446
9/32	0.2813	7.144	25/32	0.7813	19.842
19/64	0.2969	7.541	51/64	0.7969	20.239
5/16	0.3125	7.937	13/16	0.8125	20.636
21/64	0.3281	8.334	53/64	0.8281	21.033
11/32	0.3438	8.731	27/32	0.8438	21.43
23/64	0.3594	9.128	55/64	0.8594	21.827
3/8	0.375	9.525	7/8	0.875	22.224
25/64	0.3906	9.922	57/64	0.8906	22.621
13/32	0.4063	10.319	29/32	0.9063	23.018
27/64	0.4219	10.716	59/64	0.9219	23.415
7/16	0.4375	11.112	15/16	0.9375	23.812
29/64	0.4531	11.509	61/64	0.9531	24.209
15/32	0.4688	11.906	31/32	0.9688	24.606
31/64	0.4844	12.303	63/64	0.9844	25.004
1/2	0.5	12.7	1	1.0	25.4

TABLE E-1 POWERS OF 10

Unit	Name
$10^{12} = 1\,000\,000\,000\,000$	1 trillion (US, France) 1 billion (UK, Germany)
$10^9 = 1\,000\,000\,000$	1 billion (US) 1 milliard (France and Germany)
$10^6 = 1\,000\,000$	1 million
$10^3 = 1\,000$	1 thousand
$10^2 = 100$	1 hundred
$10^1 = 10$	ten
$10^0 = 1$	one (unity)
$10^{-1} = 0.1$	1 tenth
$10^{-2} = 0.01$	1 hundredth
$10^{-3} = 0.001$	1 thousandth
$10^{-6} = 0.000\,001$	1 millionth
$10^{-9} = 0.000\,000\,001$	1 billionth (US)
$10^{-12} = 0.000\,000\,000\,001$	1 trillionth (US)

R56 COMPLIANCE CHECKLIST

This checklist is provided as a guide to help prepare a site. The checklist is not a substitute for the audit form and is for use as a reference only.

Ensure that a copy of the Project Manager's compliance sheet has been completed and certified for the R56 auditor before the audit begins.

F.1 BUILDING DESIGN AND INSTALLATION

- Ceiling height is sufficient for equipment installation.
- Cable tray system meets requirements.
- Floor has been sealed as required.
- All transmission line entry ports, holes, or openings that penetrate the outer surface of the building are sealed as required.
- Lighting is adequate.
- Appropriate air conditioning is provided.
- Fire suppression equipment has been installed.
- First aid kit is available.
- Personal protective safety equipment is available for personnel working around batteries.
- Telephone, microwave link or cellular phone is available at the site.
- Phone numbers of importance are posted.
- Minimum required signage is posted in accordance with local regulations.

F.2 EXTERNAL GROUNDING (EARTHING) ELECTRODE SYSTEM

- External Ground Bus Bar installed at transmission line entry point.
- Lightning exposure at the site has been reviewed and considered.
- All grounding electrodes at the site are bonded together, forming a grounding electrode system.
- Grounding electrodes installed meet specifications and installation requirements.
- Concrete-encased electrodes are considered for new construction.
- Building and tower ground rings (when required) are properly installed.
- When used, radial grounding conductors are properly installed.

- When used, grounding electrode encasement materials meet specifications and installation requirements.
- All grounding conductors meet specifications and are properly installed.
- All grounding conductors have been routed in a continuous downward direction toward the EGB, TGB, or grounding electrode system, with no sharp bends.
- Grounding conductors are routed as straight as possible and protected from physical damage as required.
- Grounding conductors are securely fastened as required.
- Grounding conductors meet or exceed the conductor size requirements.
- Braided grounding conductors are not used anywhere in the external grounding system.
- An External Ground Bus Bar (if required) is properly installed at transmission line entry point.
- EGB grounding electrode conductor is properly installed.
- A Tower ground bus bar (if required) is properly installed.
- Soil conditions at the site have been reviewed and grounding electrode system components have been selected accordingly.
- Galvanic corrosion has been considered and installation techniques have been employed to help prevent galvanic corrosion.
- Approved bonding techniques are used to bond dissimilar metals.
- Approved methods are used for conductor connection and termination.
- Bonding surfaces for lugs and clamps are free of paint and corrosion and a conductive anti-oxidant compound has been applied.
- Painted or galvanized bonding surfaces for exothermic welding were cleaned and painted to inhibit rusting.
- The grounding electrode system resistance requirements are met.
- The tower is properly grounded and bonded, with the required number of grounding conductors.
- Guy anchor points for guyed towers are properly grounded in a manner that will minimize galvanic corrosion.
- A grounding electrode system that is appropriated for the site (e.g., dedicated communications building, outdoor cabinet, or Type A site) is installed.
- Generators external to the building are properly grounded/bonded.
- Tower mounted antenna preamplifiers are properly grounded/bonded to the tower.
- Each transmission line outer shield is properly bonded to the tower at the top of the tower near the antenna with a weather sealed transmission line grounding kit.
- Each transmission line outer shield is properly bonded to the tower or the TGB at the transition of the vertical line run with a weather sealed transmission line grounding kit.

- Each transmission line outer shield is properly bonded to the tower as required for towers greater than 61 m (200 ft.) with a weather sealed transmission line grounding kit.
- Each transmission line outer shield is properly bonded to the EGB (or grounding electrode system) with a weather sealed transmission line grounding kit.
- All fencing, gates, and gate support posts are properly bonded to the grounding electrode system.
- Ice bridge/cable supports and posts are properly bonded to the grounding electrode system.
- The following items, and other metallic items located within 1.8 m (6 ft.) of the grounding electrode system or within 1.8 m (6 ft.) of grounded objects, are properly bonded to the grounding electrode system as applicable:
 - Metallic members of all incoming telecommunications cables
 - Main electrical ground
 - Main telephone ground
 - Any other grounding electrode system at the site
 - Metallic entry ports
 - Metallic conduits, piping, and raceways
 - HVAC units
 - Vent covers and grates (if not already grounded/bonded inside)
 - Metal siding and/or roofing
 - Metal fuel storage tanks (above or below ground)
 - Skid plate or metal support frame of a prefabricated shelter
 - Metallic structures for antenna supports, light fixtures, etc.
 - Handrails and safety rails
 - Ladders and safety cages
- Roof-Mounted antenna masts and metal support structures are properly grounded.
- Building side mounted antennas are properly grounded.
- Rooftop mounted towers are properly grounded.
- Dispatch centers co-located with communications towers have considered additional grounding components/techniques to help improve protection of the site.
- Special grounding situations have followed minimum recommendations.

F.3 INTERNAL GROUNDING SYSTEM

- A properly sized master ground bus bar (MGB) is installed as required.
- MGB grounding electrode has been properly bonded and routed toward the grounding electrode system.

- All conductor connections to the MGB follow approved connection methods.
- Subsystem Ground Bar (SSGB), if required is properly installed.
- SSGB is bonded back to the MGB as required.
- All conductor connections to the SSGB follow approved connection methods.
- Where required, an internal perimeter ground bus is properly installed.
- Only ancillary equipment is bonded to the Interior Perimeter Ground Bus (IPGB)
- Each ancillary support apparatus is properly bonded to the MGB, SSGB, or IPGB.
- Surge suppression device (SPD) metal housings are bonded to the MGB, SSGB, or IPGB as required.
- Separately derived AC electrical systems are bonded to the MGB or SSGB as required.
- Primary telephone, control, and data network circuit SPDs are bonded to the MGB or SSGB as required.
- RF transmission line SPDs are bonded to the MGB or a separate equipment area SSGB as required.
- Cable trays are bonded to the MGB or SSGB as required.
- Each cable tray section is bonded to the adjoining section as required.
- Ground bus conductors and their extensions are sized as required.
- All ground bus conductors, ground bus extensions, and equipment grounding conductors are routed toward the MGB or SSGB as required.
- Bonded connections to a ground bus or its extensions have been properly insulated as required.
- Racks and cabinets have been properly bonded to the MGB, SSGB, or ground bus using approved methods.
- Any RGB located within a rack or cabinet has been properly bonded to the MGB, SSGB, or ground bus using approved methods.
- Individual system component chassis equipment is properly bonded as required.
- Secondary telephone, control, and data network circuit SPDs are properly insulated and bonded back to the MGB, or SSGB as required.
- All required control center and dispatch equipment is properly bonded back to the MGB, SSGB, or ground bus conductor as required.

F.4 POWER SOURCES

- Circuit breakers are labeled to identify the receptacle outlet they are protecting.
- Power panels are installed with proper clearance requirements.
- Outlet boxes are permanently marked to identify their assigned circuit breakers and panels.
- Power receptacle outlets are securely mounted to the supporting structure.

- Adequate service receptacle outlets are provided for the service technician.
- Each critical piece of equipment has a dedicated branch circuit and dedicated simplex receptacle.
- Power receptacles are installed by the equipment load as required.
- Extension cords, including outlet strips, are not used in the final installation.
- Exterior receptacle outlets and circuits are CGFI protected as required.
- AC power receptacle outlets and strips are of the proper type and are securely mounted as required.
- UPS and battery banks are installed with sufficient clearance to allow servicing.
- The neutral-ground bonding conductor has been properly installed in the main service disconnect as required.
- Equipment grounding conductors have been installed as required.
- Solar panels are installed away from objects that could damage or block sunlight to the panel.
- Solar panels and wind generators are installed using proper mounting practices.
- Battery racks are bolted to the floor or wall.
- Battery conductors are enclosed in PVC, metallic conduit, or raceways.
- A battery disconnect and suitable circuit protection device has been installed as required.
- Standby power generator (if installed) is installed properly.
- Standby power generator is located in an area accessibly only by authorized personnel.
- Standby power generators are installed with adequate area for servicing.
- Fuel storage tanks for standby power generators are located in a secure area.
- A dedicated electrical circuit has been provide in the generator.
- A transfer switch of the proper ampacity rating has been installed to perform the switching between commercial power and standby generator power.
- A main service disconnect has been installed as required.
- Electrical panelboard ampacity ratings are properly coordinated.

F.5 TVSS

- All SAD/MOV SPDs are properly installed as required.
- Primary SPDs for telephone circuits are installed as required.
- Secondary SPDs for telephone circuits are installed as required.
- Primary SPDs for control circuits are installed as required.
- Secondary SPDs for control circuits are installed as required.

- Primary SPDs for data network circuits are installed as required.
- Secondary SPDs for data network circuits are installed as required.
- All RF transmission lines, including unused spares, have coaxial RF type SPDs properly installed.
- If a tower top amplifier is installed, the sample port and its control cables have SPDs installed as required.
- Tower lighting system AC power and data/alarm circuits have SPDs properly installed as required.

F.6 EQUIPMENT INSTALLATION

- Equipment spacing and aisle widths are adequate and conform to guidelines.
- Equipment is level and plumb.
- Equipment is square with respect to surrounding equipment and walls.
- Where applicable, seismic installation practices are observed.
- Cabinets and racks are secured as required.
- Cable groups of different function maintain minimum separation or 5 cm (2 in) as required.
- RF cables meet or exceed minimum bending radius requirements.
- Plenum-rated cables are installed where required.
- Cables are of adequate length with no excess.
- Cables are properly secured at the required intervals.
- AC power conductors installed in cable trays meet minimum installation requirements.
- Cables are properly identified at both ends using a standard labeling system.
- Distribution frame wiring confirms to the proper punch-down or wire wrap techniques.
- CAT-5 or CAT-6 data cables maintain the proper separation distance from AC power cables.
- CAT-5 or CAT-6 data cables do not have sharp ends.
- CAT-5 or CAT-6 cables meet all other installation requirements.
- Cables located below raised flooring systems are properly installed.
- Cables located above suspended ceilings are properly installed.
- Electrostatic discharge handling practices are observed as required.

Index

- AC power
 - cabling to equipment 9-16
 - SPD component requirements 7-5
 - SPD installation requirements 7-33
 - SPD requirements for facilities 7-5, 7-27
- acceptable rectifier types 6-19
- acceptance testing 2-16
- access point and wireless router grounding 4-84
- air conditioning 3-13
- air terminals 2-21
- alarms
 - fire detection 3-26
 - temperature 3-16

- backfilling requirements 2-13
- batteries
 - charging 6-33
 - installation 6-34
 - maintenance disconnect 6-35
 - multiple 6-32
 - required signage 6-30
 - temperature requirements 6-33
- battery backup duration 6-31
- battery backup, high rate applications 6-31
- battery backup, long duration 6-31
- battery containment area 6-30
- battery safety 6-28
- battery safety equipment 3-30
- battery systems 6-27
- bending radius for grounding conductors 4-29
- bonding cable tray sections 5-45
- bonding grid 5-68
- bonding jumper 5-30
- bonding methods
 - exothermic welding 4-41
 - irreversible high-compression fittings 4-43

A

- alternate power sources 6-25
- Americans With Disabilities Act 2-9
- anchoring equipment to raised floors 9-9
- ancillary support apparatus
 - bonding to MGB 5-46
- antenna masts
 - grounding 4-74
- antennas
 - EME considerations A-1
 - interference protection recommendations 8-1
 - loading requirements 2-23
 - protection requirements (final output-to-antenna) .. 8-2
- anti-oxidant 5-32
- arctic regions
 - grounding in 4-99
- Australian standards 1-8

B

- bonding requirements to MGB, SSGB, IPGB, and ground bus conductor 5-40
- bonding SSGB to grounding system 5-18
- bonding to external grounding system 4-40
- bonding to ground (earth) bus conductors 5-38
- bonding to internal ground system 5-61
- bonding to the MGB, SSGB And RGB 5-36
- branch circuit breaker 6-8
- building ground ring 4-22
- buildings
 - design requirements 3-1
 - grounding 5-54
- buildings/shelter
 - definition 3-2
 - off-loading considerations 3-7
- buildings/shelters
 - lighting 3-22
 - sealing 3-13
- bus bar
 - external grounding 4-30
 - IGB 5-29
 - rack ground 5-20
 - SSGB 5-15
 - tower ground 4-32

cabinet	
definition	3-3
grounding	5-44
cable	
support requirements	2-26
cable bridge	
grounding	4-71
cable management	3-19
cable tray	
bonding jumper installation	5-45
installation	3-18, 3-21
layout and design	3-20
safety	3-22
selection	3-18
under raised floors	3-19
wire mesh	3-19
cable trays	
requirements for installing cabling into trays	9-15
cabling	
AC power to equipment	9-16
computer network	9-18–9-26
control/data cabling to equipment	9-17
DC power to equipment	9-17
distribution frame configurations	9-29
distribution frame wiring	9-30
equipment	9-11–9-31
fiber optic	2-21
labeling	9-30
optical fiber	9-26
power cabling capacity	6-22
requirements using trays	9-15
RF	9-28
within plenums and air-handling spaces	9-12
within telephone wiring environment	9-28
DC power budget	6-23
DC power distribution center	6-21
DC power plant	
bonding	5-43
dedicated communications buildings	
grounding	4-59
definition of surge suppression modes	7-4
disconnect for battery maintenance	6-35
disconnect for main electrical service	6-3
disconnect, fused	6-3
dispatch centers co-located with tower	4-81
dispatch positions, grounding	5-62

C

calculating soil resistivity for complex ground	
rod systems	B-30
calculating soil resistivity from test results	B-19
cathodic protection	4-57
causes of power quality problems	6-12
caution symbol, definition	1-2
ceiling considerations	3-10
charging backup batteries	6-33
checklist	F-1
circuit breaker	
branch	6-8
circuit protection	6-8
committee members	1-1
communication bonding backbone conductor	5-26, 5-39
communications systems on-site	3-30
concrete	
anchors	2-13
forms	2-13
mounting equipment on floors	9-6
preparation	2-13
temperature requirements	2-13
concrete foundation design	2-12
concrete-encased electrodes	2-12, 4-20, 4-92
planning	2-12
conductors	
requirements	6-9
conduit	
grounding method	5-48
requirements	6-9
constructability review	2-7
construction	
towers	2-25
controlled ferroresonant rectifier	6-19
corrosion control	4-34, 4-38
cathodic protection	4-57
corrosion, galvanic	4-36
counterpoise grounding conductors	4-24

D

dissimilar metals and corrosion control	4-34
distance between tower and building	2-20
down conductor grounding	4-75
drawings	
site development	2-3
site drawings of record	2-27
tower design	2-18
drip loop	
example	2-26

effect of ground rod size on resistance to earth	4-15
effects of power quality problems	6-15
electrical service installation	2-10
electrical service requirements	6-2
electrical service requirements, interior	6-6
electrodes, grounding (earthing)	4-9
electrolytic ground rods	4-16, 4-92
electromagnetic energy	
action thresholds	A-27
EME zoning	A-10
engineering considerations	A-14
environmental evaluation	A-2
exposure evaluation	A-6
exposure standards and limits guidelines	A-3
general information regarding criteria	A-1
personal monitors	A-27
personal protective equipment	A-26
signage	A-24
work practices	A-20
electrostatic discharge	
equipment installation precautions	9-31
electrostatic discharge protection	C-1
email address for this manual	1-2
emergency lighting	3-23
encasement material	
grounding electrodes	4-27
fans, exhaust	3-15
Federal Aviation Administration	2-22
Federal Clean Water Act (FCWA)	2-10
fencing	
grounding	4-68
ferroresonant rectifier	6-19
fiber optic	
cabling	2-21, 9-26
safety precautions	9-26
fire	
alarm	3-26
protection	3-23
suppression	2-10
suppression systems	3-26
first aid equipment	3-29
floors	
anchoring equipment to raised floors	9-9
cable management under	3-19
design considerations	3-11
equipment mounting on wood/fiberglass floors	9-8
loading	3-9
securing equipment to	9-3

E

enhancing grounding electrode systems	4-48
entry port	4-31
equipment	
anchoring	9-5–9-10
installation within racks	9-10
isolated mounting	9-8
RF cabling	9-28
equipment	
cable labeling	9-30
cabling	9-11–9-31
cabling within telephone wiring environment	9-28
computer network cabling	9-18–9-26
control/data cabling	9-17
DC power cabling	9-17
EME personal monitors	A-27
EME personal protective equipment	A-26
mounting on concrete floors	9-6
mounting on wood or fiberglass floors	9-8
mounting plumb and squareness	9-5
optical fiber cabling	9-26
equipment and ancillary support apparatus bonding	5-41
equipment grounding (earthing) conductor	5-29
equipment spacing requirements	9-2
ESD. See electrostatic discharge.	
exhaust fans	3-15
exothermic welding	4-41

F

foundation and soils monitoring requirements	2-14
foundation considerations	3-8
foundation design for prefabricated shelters	2-12
foundation monitoring services	2-11
foundations	2-12
fuel supply for backup power generators	6-38
fused disconnect	6-3

G

- Galvanic corrosion4-36
 - example of4-56
- gates
 - grounding4-68
- general bonding requirements5-31
- General Conversions and Formulas E-1
- generator
 - fuel supply6-38
 - grounding6-42
 - installation6-42
 - installation plan6-40
 - placement6-37
 - standby6-35
 - startup6-43
- generator safety6-43
- generators
 - grounding4-59
- geotechnical considerations2-6
- global positioning system
 - receiver TVSS protection7-44
- glossary of terms1-11
- ground bus conductor
 - sizes5-26
- ground bus conductor routing
 - illustrations5-23
- ground bus extension conductors5-24
- ground conductor separation5-22
- ground plates 4-19, 4-93
- ground ring
 - building and tower4-22
- ground rods
 - angled4-13
 - concrete-encased electrodes4-20
 - effect of length on resistance4-15
 - electrolytic4-16
 - illustration4-11
 - installation4-12
 - parallel4-15
 - plates4-19
 - specifications4-11
 - splicing4-14
 - typical single rod installation4-13
- ground system testing
 - safety precautionsD-1
- ground test wells4-27
- ground zone, isolated 3-18, 6-9
- grounding
 - arctic regions4-99
 - bending radius5-19
 - bonding SSGB5-18
 - buildings5-54
 - cable bridge/ice bridge4-71
 - dedicated communications buildings4-59
 - dispatch centers5-62
 - dispatch centers co-located with tower4-81
 - down conductors4-75
 - equipment rooms located in same building5-63
 - fences and gates4-68
 - generators4-59, 6-42
 - guyed tower guy anchor points4-54
 - guyed towers4-53
 - interior binding conductors5-20
 - items to be bonded to internal grounding system ..5-61
 - metallic building siding4-74
 - metallic objects requiring bonding4-67
 - mountaintops4-92
 - network operator positions5-62, 5-64
 - outdoor cabinets4-61
 - PANI system5-37
 - racks and cabinets5-44
 - raised flooring systems5-68
 - RF transmission lines and preamplifiers4-62
 - roof-mounted antenna masts4-74
 - rooftop and integrated communication sites4-89
 - rooftop-mounted tower structures4-79
 - sand, coral and limestone environments4-96
 - self-supporting towers4-51
 - separately derived AC systems5-42
 - shallow topsoil areas4-97
 - side-mounted antenna4-77
 - signal carrying cables5-53
 - sites with limited space4-90
 - soilless areas4-96
 - SSGB location5-18
 - SSGB specifications5-17
 - stand-alone equipment shelter5-55
 - stand-alone equipment shelters5-54
 - towers with limited space4-92
 - two or more structures or facilities located
 - in same area4-83
 - wireless access points and routers4-84
 - wooden poles4-58
- grounding (earthing)
 - metal shipping containers4-87
 - minimum requirements4-44
- grounding (earthing) electrode
 - spacing for maximum effectivity4-10

grounding (earthing) electrode system		grounding electrode system resistance	4-46
component and installation requirements	4-7	grounding electrode system testing	D-1
grounding (earthing) electrodes	4-9	grounding equalizer conductor	5-39
grounding conductor specifications	5-59	grounding equipment and ancillary support apparatus .	5-34
grounding conductors		grounding in	4-97
bending	4-29	grounding method for metallic pipe or conduit	5-48
counterpoise	4-24	grounding multiple network operator position clusters	5-66
general specifications	4-28	grounding system	
protecting and securing	4-30	defined	5-3
radial	4-24	special situations	4-45
grounding dry type isolation transformer	5-43	supplementing	4-48
grounding electrode		tower	4-50
encasement material	4-27	grounding the MGB	5-14
sphere of influence	4-9	guy anchor points	
		grounding	4-54
		guyed towers	
		comparison	2-18
		grounding	4-53

H

hantavirus precautions	3-13	HVAC	
hardwiring of receptacles	6-10	alarms	3-16
heating		heat pumps	3-16
heat pumps	3-16	preventive maintenance program	3-16
thermostats	3-16	thermostats	3-16
heating, ventilation, and air conditioning	3-13	wall-mounted units	3-15
horizontal ground rods	4-92	HVAC systems	3-13
horizontal lightning rods	2-21		

I

ice bridge		interior grounding (earthing) and bonding conductors .	5-20
grounding	4-71	internal ground system	
isolation from building	2-21	items to be bonded	5-61
support requirements	2-26	internal grounding system	
incoming power lines and telecommunication cables		components	5-7
grounding	5-63	internal perimeter ground (earth) bus	
installation		location	5-28
angled ground rods	4-13	internal perimeter ground (earth) bus (IPGB)	5-28
fire extinguishers	3-25	internal perimeter ground (earth) bus conductor	
transmission lines	2-25	specifications	5-29
typical single ground rod	4-13	irreversible high-compression fittings	4-43
installation requirements		isolated ground zone	3-18, 6-9
grounding system	4-7	isolation transformer	
installation specifications of the MGB	5-12	dry type, grounding	5-43
installing batteries	6-34		
installing generators	6-40, 6-42		
integrated cable entry port	4-31		
integrated communications site grounding system	5-68		
interconnection wiring between the			
generator, transfer switch, and site AC mains	6-40		
interference			
received protection	8-3		

- jumper, bonding5-30
- ## J
- ## L
- labeling
 cables9-30
- land surveys2-4
- layout
 spacing requirements9-2
- light duty site4-44
- lighting
 emergency3-23
 towers, TVSS7-45
- lighting considerations3-22
- lightning
 activity worldwide4-3
 central office protection3-17
 frequency4-4
 isolation of ice bridge2-21
- main service disconnect6-3
- manual email address1-2
- master ground bus bar5-9
- material safety and data sheets6-28
- metal shipping containers used as communication sites
 grounding4-87
- metallic building siding, grounding4-74
- metallic objects requiring bonding4-67
- metals
 dissimilar, preventing corrosion4-34
- Metric/English Units ConversionE-1
- MGB
 grounding5-14
 specifications5-12
- network operator location
 grounding5-64
- network operator positions
 grounding5-62
- Occupational Safety and Health Administration2-12
- off-loading buildings/shelters3-7
- organization of this manual1-1
- outdoor cabinets
 grounding4-61
- maps4-3
 reducing effects of2-19
- lightning rods2-21
- line-to-neutral (normal mode) surge suppression6-5
- loading report example2-23
- loading requirements
 towers2-23
- location
 site buildings/building/shelter design and location con-
 siderations3-5
- location of neutral-ground bond2-3, 6-4
- location of utility entrance2-3
- lockout/tagout6-1
- low voltage disconnect6-21
- ## M
- MGB grounding conductor
 labeling5-14
- minimum grounding (earthing) requirements4-44
- minimum TVSS requirements7-3
- monopole towers
 comparison2-18
 grounding4-51
- Motorola Site Design and Integration Team2-2
- mountaintops
 grounding4-92
- multiple battery strings6-32
- multiple network operator position clusters
 grounding5-66
- ## N
- neutral conductor6-9
- neutral-ground bond5-42
 location2-3
 location of6-4
- New Zealand standards1-8
- nomograph, soil resistivity testingB-12
- ## O
- outdoor electrical equipment6-7
- outdoor receptacles6-7
- overcurrent protection6-21

panel board marking	6-6
PANI grounding system sequence	5-37
parallel ground rods	4-15
permits	2-9
permitting, zoning, code and regulatory considerations ..	2-9
personal protective equipment	6-29
placement of generator	6-37
planning	
location of neutral-ground bond	2-3
location of utility entrance	2-3
site development drawings	2-3
staking considerations	2-4
temporary facilities	2-5
plate, ground	4-19
plenum cabling	6-22
power	
stand-alone system	6-25
power cabling	
floor and ceiling, plenums	6-22

R56 Manual	
organization	1-1
rack	
definition	3-4
rack ground bus bar (RGB)	5-20
racks	
grounding	5-44
radial grounding conductors	4-24, 4-92, 4-98
raised flooring support system grounding connection meth-	
ods	5-35
raised flooring system	
bonding grid	5-68
receiver protection requirements	8-3
receptacle	
outdoor	6-7
receptacle strips	6-11
receptacles	
hardwiring	6-10
rectifier	
ferroresonant	6-19
silicon-controlled	6-20
switchmode	6-20

P

power cabling capacity	6-22
power panel requirements	6-7
power quality	6-11
effects of problems	6-15
problem remedies	6-16
problems	6-12
recommended test thresholds	6-17
power quality action plan	6-17
power quality testing locations	6-18
power sources	3-28
alternatives	6-25
protecting at central offices	3-17
power supply	
uninterruptible	6-24
power system	
DC distribution center	6-21
sizing	6-20
preamplifier	
grounding	4-62
preventive maintenance	
HVAC	3-16
protecting and securing grounding conductors	4-30

R

rectifier sizing	6-20
rectifiers	6-19
referenced standards	1-4
regulations	
towers	2-22
regulatory considerations	2-9
remedies for power quality problems	6-16
requirements	
foundation and soils monitoring	2-14
requirements for working space	6-6
resistance to earth of a straight horizontal electrode	4-25
rest platforms	2-17
RF	
interference protection recommendations	8-1
minimum receiver protection requirements	8-3
minimum transmitter protection requirements	8-2
transient voltage surge suppression	7-36
RF energy exposure	2-1
RF transmission lines	
grounding	4-62
rod arrangement, soil resistivity testing	B-7
rooftop and integrated communications sites	
grounding	4-89
rooftop mounted towers	
grounding	4-79

S

- safety
 - batteries 3-30, 6-28
 - cable trays3-22
 - definition of caution symbol 1-2
 - definition of warning symbol 1-2
 - EME exposure standards and limits guidelinesA-3
 - EME personal monitorsA-27
 - EME personal protective equipmentA-26
 - EME warning 1-3
 - emergency lighting3-23
 - equipment required at communication sites3-29
 - eyewash solution6-29
 - fire protection3-23
 - general guidelines 1-3
 - generators6-43
 - ground system testingD-1
 - hantavirus precautions3-13
 - on-site communications3-30
 - optical fiber cabling9-26
 - RF energy exposure2-1
 - signage3-31
 - soil resistivity testing B-5
 - statements and symbols defined 1-2
 - towers2-21
 - warning signage3-27
 - work practices involving EMEA-20
- safety climb2-17
- sand, coral and limestone areas4-96
- sealing buildings/shelters3-13
- securing equipment to flooring9-5
- securing towers2-22
- seismic
 - anchoring9-6
 - equipment considerations9-4
 - equipment mounting recommendations9-3
- seismic considerations 3-8, 9-4
- selecting cable trays3-18
- self-supporting ice bridge2-26
- self-supporting towers
 - comparison2-18
 - grounding4-51
- Separately derived AC system neutral-ground bond5-42
- separately derived systems
 - SPD requirements7-7
- separately derived transformers6-5
- shallow topsoil4-97
- shelter
 - definition3-3
- side mounted antenna
 - grounding4-77
- signage
 - battery rooms 6-30
 - EME caution and warnings A-24
 - MGB grounding conductor 5-14
 - panel boards and switch boards 6-6
- signal carrying cables
 - grounding 5-53
- signs
 - minimum required onsite 3-31
 - warning 3-27
- silicon controlled rectifier 6-20
- single ground rod installation 4-13
- single point ground system definition 5-3
- site
 - AC power SPD requirements7-5, 7-27
 - drawings of record2-27
 - facility readiness 9-1
- site acceptance testing 2-16
- site categories 3-1
 - building 3-2
 - cabinet 3-3
 - rack 3-4
 - shelter 3-3
 - vault 3-4
- Site Design and Integration Team 2-2
- site development drawings 2-3
- site development task list 2-2
- site preparation
 - soil resistivity testing B-4
- site walks 2-7
- sites with limited space for external grounding systems 4-90
- sizing of power system rectifier 6-20
- sizing the site power system 6-20
- soil requirements 2-6
- soil resistivity
 - site preparation B-4
 - test procedure B-6
 - testing methods B-4
 - variability B-1
- soil resistivity testing
 - blank worksheet B-15
 - calculations B-19
 - complex ground rod calculations B-30
 - equipment and supplies B-5
 - example worksheet B-11
 - interpreting results B-10
 - rod arrangement B-7
- soil resistivity testing safety considerations B-5
- soilless ground system 4-96
- solar power system
 - requirements 6-26

- transient voltage surge suppression
 AC power SPD requirements7-5
 GPS receiver protection7-44
 Installation requirements7-33
 minimum required for typical installation7-3
 requirements for separately derived systems7-7
 RF components protection7-36
 SPD component test requirements7-47
 SPDs (definition of types)7-27
 suppression modes defined7-4
 technologies7-4
 telephone line SPD requirements7-34
- Ufer ground 2-12, 4-20
unacceptable connection methods for grounding and bonding
 conductors5-32
under floors3-19
- variability of soil resistivityB-1
- wall-mounted HVAC3-15
warning
 EME monitoring1-3
warning symbol definition1-2
weatherproofing3-11
websites
 standards organizations1-10
wind/solar systems6-25
wire mesh cable trays3-19
- zoning considerations2-9
- tower lighting protection 7-45
transmission line
 drip loop 2-26
 installation requirements 2-25
TVSS. see transient voltage surge suppression.
type “A” site 4-44
type “A” site grounding (earthing) electrode system resistance 4-46
type “B” site 4-45
type “B” site grounding (earthing) electrode system resistance 4-47
- U**
uninterruptible power supply requirements 6-24
utility entrance, location 2-3
utility locator service 2-11
- V**
vault
 definition 3-4
- W**
wire size
 metric/English equivalents 5-27
wooden poles
 grounding 4-58
working space
 48 VDC or 600 VAC equipment 6-6
working space requirements 6-6
worksheet for soil resistivity testing B-15
worksheet sample, soil resistivity testing B-11
- Z**